

# OPERATION MANUAL

## ATX-2

### Automatic Transmission Fluid Exchanger

#### WARNING

**DO NOT** pour anything except new transmission fluid into the fill port. Serious damage will result.

The ATX-2 must be connected to a **FULLY CHARGED 12 volt battery**. This should be the battery in the vehicle being serviced.

Do not use a battery charger to power the ATX-2.

Use of undercharged batteries and battery chargers will damage the ATX-2 and void the warranty.



**RTI Technologies, Inc**  
4075 East Market St.  
York, PA 17402  
800-468-2321  
[www.rtitech.com](http://www.rtitech.com)

Manual P/N 035-81061-00 (Rev B)

# TABLE OF CONTENTS

Component Description . . . . .	2
Safety Precautions . . . . .	3
Keypad Functions . . . . .	4
Connecting to the Transmission System . . . . .	6
Flush . . . . .	8
Drain Pan . . . . .	8
Fluid Exchange . . . . .	9
-1/2 Quart . . . . .	9
+1/2 Quart . . . . .	9
Disconnecting from the Transmission System . . . . .	10
Empty Used . . . . .	11
Empty New . . . . .	11
Maintenance . . . . .	12
Calibration . . . . .	13
Calibration of a Load Cell . . . . .	14
Parts Identification . . . . .	15
Flow & Wiring Diagram . . . . .	16

## **Calibration - A Good Practice**

The ATX-2 is the most accurate of all transmission fluid exchange equipment due to the advanced load cell technology designed into the unit.

Most operating problems are usually fixed by performing a simple calibration procedure.

A good practice is to periodically calibrate the ATX-2 to ensure optimum performance.

Precision calibration weight(s) are included with the ATX-2.

# COMPONENT DESCRIPTION

Unpack all components. Use laminated placard to verify fitting adapter quantities.

Contact RTI if any items are missing or damaged.

12 INCH HOSE ADAPTER  
(STRAIGHT)



12 INCH HOSE ADAPTER  
(90°)

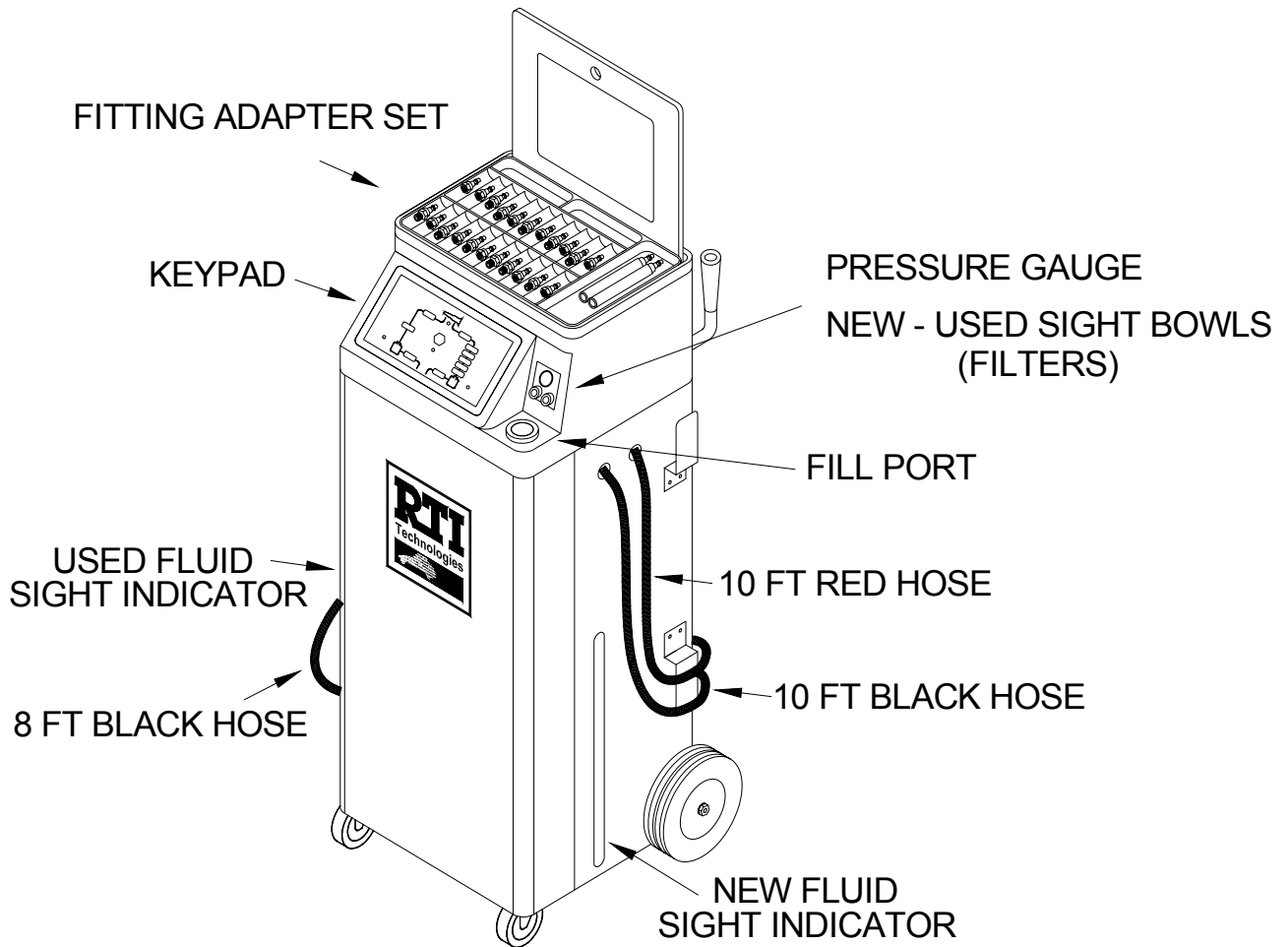

# Safety Precautions

**WARNING: Failure to follow these precautions can result in serious injury or death.**

- Read and understand the Operation Manual completely before operating this unit.
- Always wear proper eye and skin protection when operating and maintaining this equipment.
- Take precautions to keep clothing, hair, hands, hoses etc. away from all moving parts of the vehicle.
- Many Automatic Transmission systems can be extremely hot and operate at high pressures. **Always use extreme caution when connecting and dis-connecting hoses and adapters.**
- Always keep a fire extinguishing device nearby when working with flammable liquids.
- Choose a well ventilated work area and avoid breathing any harmful fumes when performing a transmission fluid exchange.
- Check engine oil level and coolant level. Refill if low. Do not perform the exchange if either is low.
- Flush solutions are combustible and are harmful or fatal if swallowed. If swallowed call doctor immediately and do not induce vomiting. If Flush Solution gets in eyes flush with water immediately. For contact with skin wash with soap and water. Apply skin lotion if necessary to sooth irritation.
- Immediately clean up any transmission fluid spills and use proper container for disposal.
- Comply with local, state, and federal regulations for fluid disposal.
- **Material Safety Data Sheets** (MSDS) must be obtained on all chemicals and placed in a shop file for reference.

## **IMPORTANT**

**Check transmission fluid level according to manufacturer's instructions before connecting the ATX-2**

**Adjust fluid level if required**

# KEYPAD FUNCTIONS

The ATX-2 is an automatic transmission fluid exchanger featuring state-of-the-art electronic controls with digital weight scales measuring the automatic transmission fluid coming into and going out of the machine. Operation of the ATX-2 is intuitive and very easy to master.

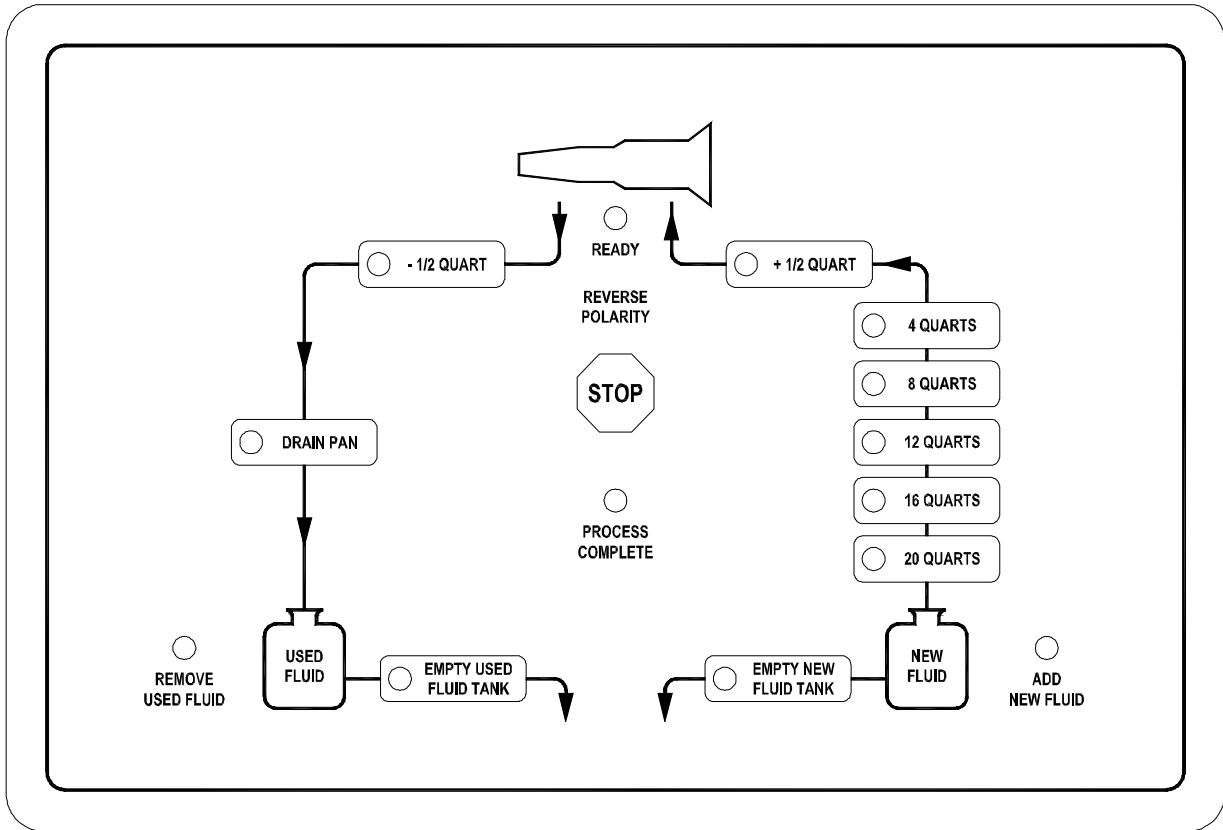

Transmission fluid is recovered from vehicle and filtered before collecting in the ATX-2 used fluid tank. The used fluid is pumped by the vehicle transmission pump and when the procedure is complete, the ATX-2 buzzer will sound continuously until the stop button is pressed. Refer to page 8 for complete instructions.

DRAIN PAN

4 QUARTS

8 QUARTS

12 QUARTS

16 QUARTS

20 QUARTS

EMPTY NEW FLUID TANK

Filters and exchanges the used transmission fluid in the vehicle for new from the ATX-2. The fluid is moved by both the vehicle transmission pump removing the used inside the vehicle and the ATX-2 pump replacing it with new. The procedure is complete when the buzzer sounds continuously until the stop button is pressed. Refer to page 9 for complete instructions

Transmission fluid is emptied completely from the new fluid tank inside the ATX-2. It can be stored in a bulk container for later use. This procedure is performed if a change in transmission fluid types is required. The ATX-2 buzzer will sound continuously until the stop button is pushed when procedure is complete. Refer to page 11 for complete instructions.

# KEYPAD FUNCTIONS

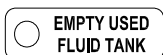

Transmission fluid is emptied completely from the used fluid tank inside the ATX-2 into a bulk used tank for proper disposal. This procedure is performed when the used fluid tank is full or the used fluid tank capacity is not sufficient to perform selected exchange. The ATX-2 buzzer will sound continuously until the stop button is pushed when procedure is complete. Refer to page 11 for complete instructions.

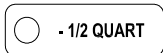

Used after the exchange process if fluid level is too high on the transmission dip stick. Removes 1/2 quart of fluid from the transmission. Fluid is moved by the vehicle transmission pump into the used fluid tank of the ATX-2. The ATX-2 buzzer will sound continuously until the stop button is pushed when procedure is complete. Refer to page 9 for complete instructions.

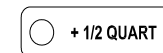

Used after the exchange process if fluid level is too low on the transmission dip stick. Adds 1/2 quart of transmission fluid to the transmission from the ATX-2 new fluid tank. Fluid is moved by the pump inside the ATX-2. The ATX-2 buzzer will sound continuously until the stop button is pushed when procedure is complete. Refer to page 9 for complete instructions.



Stops any procedure the moment it is pushed, also used at the end of a procedure to acknowledge completion of process and turn buzzer off.



Illuminates when battery connection is backwards.



Illuminates when the used tank is too full or flashes when the capacity remaining is less than exchange amount selected. The EMPTY Used procedure must be run to continue operation of the ATX-2.



Illuminates when the new fluid tank is empty or flashes when the new fluid level is less than the selected exchange amount. The operator must add fluid to the new fluid tank of the ATX-2 through the fill port.



Illuminates when the vehicle engine is running and connected properly to the ATX-2.



Illuminates when the selected process is complete. The buzzer will sound continuously when this is illuminated.

**Caution:**

**Always use fingers to operate keypad. Use of sharp objects will cause damage and void the warranty.**

# CONNECTING TO THE TRANSMISSION SYSTEM

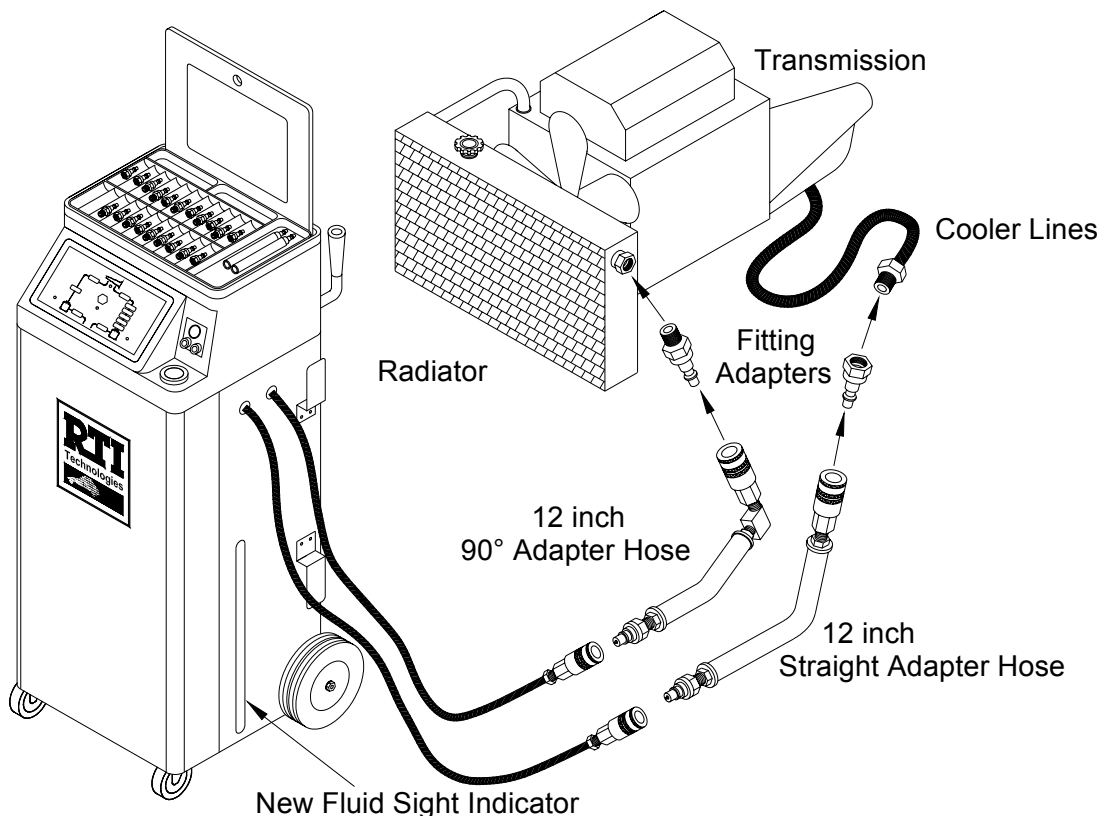

## IMPORTANT

**Check transmission fluid level according to manufacturer's instructions before connecting the ATX-2**

**Adjust fluid level if required**

1. Add desired amount of transmission fluid to the new fluid tank through the ATX-2 fill port. Monitor fluid level in the ATX-2 through the Level Indicator.
2. Locate and disconnect the transmission cooler lines at the most convenient location:
  - A. At cooler line connecting to radiator usually most accessible if vehicle is not on lift.
  - B. At clamped rubber hose connection to transmission cooler usually most accessible if vehicle is on a lift. Cooler is most often in front of the radiator.
  - C. At cooler line connecting to the transmission usually requires vehicle to be on a lift.

# CONNECTING TO THE TRANSMISSION SYSTEM

3. Select and install proper fitting adapters to disconnect points. Use closest matching adapter and o-ring to seal any leaks if exact matching adapter can not be found. In some cases it may be easier to use one of the open end rubber hose adapters on the disconnected male fitting on the cooler line then to select the matching adapter.
4. Connect 12 inch adapter hoses to fitting adapters.
5. Connect 10 ft black and red hoses (right side of ATX-2) to the 12 inch adapter hoses.

## IMPORTANT

**Attempt to pull hoses apart to ensure couplers are attached properly**

6. Connect red (positive) clamp on power cable to red (positive) terminal on vehicle battery. Connect the black (negative) clamp to a ground on vehicle frame. All lights on keypad should illuminate for 1 second and buzzer should pulse. If not, check connections and make sure REVERSE POLARITY light is not illuminated.

**WARNING: Handle battery connection cable with extreme caution. Batteries generate explosive gases during normal operation. Working in the vicinity of a lead-acid or other automotive battery is dangerous. Wear eye protection. Never smoke or allow a spark or flame in the vicinity of the battery. Do not connect the black power clip to the negative post of the battery to avoid a spark.**

7. Set the park brake and turn engine on, listen for the buzzer to sound once loudly and for the READY light on the keypad to stay illuminated. The ATX-2 pressure gauge on the control panel will indicate a positive pressure if the connection to the transmission is correct.

If buzzer does not sound and light does not illuminate **IMMEDIATELY TURN ENGINE OFF** and switch the black and red 10 ft hoses and repeat the above.

- A. For most Chrysler and Mitsubishi vehicles the transmission pump will be functioning when the vehicle is in "Neutral" instead of "Park". Perform the service in Neutral gear on these vehicles.
8. Once the ATX-2 is connected properly (READY light stays illuminated) the machine automatically goes into circulate mode. Check hoses for heat, if circulate is working correctly both hoses should be warm to the touch.
9. The ATX-2 pressure gauge will indicate the transmission operating pressure. Refer to the manufacturer's recommended pressure to determine if the transmission system is functioning correctly.

# FLUSH

1. Vehicle engine is running and the ATX-2 is connected as previously described, READY light is illuminated.
2. Slowly add Flush Solution as recommended by the supplier into the vehicle through the transmission system dip stick port.
3. The ATX-2 will now circulate the solution through the transmission system until a procedure is selected. The Flush Solution will be removed from the system during the exchange procedure.

# DRAIN PAN

**Note: If transmission filter is to be replaced, perform the following procedure before removing the transmission pan. If not, skip to the next procedure.**

1. Vehicle engine is running and the ATX-2 is connected as previously described, READY light is illuminated.
2. Press the DRAIN PAN button on the keypad.
3. Buzzer will sound once and DRAIN PAN light will stay illuminated. If an error occurs the buzzer will sound three times and the ATX-2 will not proceed with the procedure, check all connections.
4. Vehicle transmission pump will empty contents of transmission system into the ATX-2 used fluid tank. Liquid level can be viewed through the Used Fluid Level Indicator on the left side of the ATX-2.
5. When vehicle pan is emptied of transmission fluid the ATX-2 will automatically switch to the circulate mode, the buzzer will sound continuously and the PROCESS COMPLETE light will stay illuminated until the STOP button is pressed.
6. Turn the vehicle off IMMEDIATELY after ATX-2 buzzer sounds. The vehicle is now ready to have the transmission pan removed.
7. After the pan is replaced, refill the pan using the +1/2 Quart button (refer to the **+1/2 QUART** section). Check the transmission dip stick periodically while refilling to reach proper level.

**Note: If the ATX will not add +1/2 quart, there may not be enough fluid remaining in the transmission to satisfy the minimum pressure requirement. To correct this situation, stop engine. Press Empty New Fluid and manually monitor the level of fluid in the new fluid tank. Press the Stop button after two quarts have been added to the transmission. Restart vehicle and verify the Ready LED is illuminated. Check fluid level in the transmission. The +1/2 Quart and -1/2 Quart procedures can be used to adjust the level.**

**Caution: Do not let the engine run for more than one minute after the ATX-2 buzzer sounds. Letting the transmission run with an empty pan for an extended amount of time can cause serious damage to the transmission system.**

# FLUID EXCHANGE (4,8,12,16,20 QUARTS)

1. Vehicle engine is running and the ATX-2 is connected as previously described, READY light is illuminated.
2. Determine vehicle transmission fluid capacity from the vehicle operator or service manual.
3. Press the corresponding QUART button, always round up (for example if vehicle capacity is 6.5 quarts an 8 quart exchange would be selected).
4. The change of fluid can be monitored through the ATX-2 Old-New Sight Bowls. These bowls display the new bright red fluid leaving the ATX-2 and the dirty brown to black fluid coming from the vehicle transmission system. The color of the used should become almost equal to the new as the exchange ends. The liquid levels can be viewed through the Level Indicators on either side of the ATX-2 (left side for used, right side for new).
5. When the exchange of transmission fluid is complete the ATX-2 will automatically switch to the bypass loop, the buzzer will sound continuously and the PROCESS COMPLETE light will stay illuminated until the STOP button is pressed.
6. Check transmission dip stick for level. Use +1/2, -1/2 QUART buttons as required to correct fluid level.

## -1/2 QUART

1. Vehicle engine is running and the ATX-2 is connected as previously described, READY light is illuminated.
2. Check transmission dip stick. Press the -1/2 QUART button to lower the fluid level if the transmission system is overfilled.
3. When process is complete the buzzer will sound continuously and the PROCESS COMPLETE light will stay illuminated until the STOP button is pressed.
4. Check transmission dip stick for appropriate level.

## +1/2 QUART

1. Vehicle engine is running and the ATX-2 is connected as previously described, READY light is illuminated.
2. Check transmission dip stick. Press the +1/2 QUART button to raise the fluid level if the transmission system is under filled.
3. When process is complete the buzzer will sound continuously and the PROCESS COMPLETE light will stay illuminated until the STOP button is pressed.
4. Check transmission dip stick for appropriate level.

# DISCONNECTING FROM THE TRANSMISSION SYSTEM

- Caution -

**Hoses, fitting adapters and the engine may be extremely hot. Use extreme caution when disconnecting.**

1. Turn vehicle engine off. READY light should go off. Make sure READY light is **OFF** before proceeding.
2. Disconnect ATX-2 from the vehicle battery.
3. Disconnect 10 ft black and red hoses from the 12 inch adapter hoses.
4. Disconnect 12 inch adapter hoses from fitting adapters connected to the transmission system.
5. Disconnect fitting adapters from the transmission system connection points.
6. Reconnect cooler lines. Do not cross-thread cooler line fittings when reconnecting to the transmission system.
7. Start vehicle engine and check for leaks at cooler line connection points, tighten if necessary. Vehicle transmission service is complete once transmission system is leak free.

## GOOD PRACTICE

**Empty used fluid tank after every exchange procedure.**

## EMPTY USED

1. Connect red (positive) clamp on ATX power cable to red (positive) terminal on vehicle battery. Connect the black (negative) clamp to a ground on vehicle frame. Vehicle engine is turned OFF. The ATX-2 **10 ft black and red hoses must be disconnected from the transmission**. READY light is off.
2. Place end of **8 ft black hose (left side of ATX-2)** hose in bulk used fluid container. Open ball valve on the end of the hose.
3. Press the EMPTY USED button on the keypad.
4. Buzzer will sound and used transmission fluid will empty from the used tank inside the ATX-2 to the bulk container. Level can be viewed through the Level Indicator on the left side of the ATX-2.
5. Procedure will run until used tank is completely emptied or the STOP button is pressed. If process is allowed to run until completion (30 seconds after used fluid tank is empty), the buzzer will sound continuously and the PROCESS COMPLETE light will stay illuminated until the STOP button is pressed.
6. **Close ball valve** on the black hose and remove it from the bulk used fluid container.

## EMPTY NEW

1. Connect red (positive) clamp on ATX power cable to red (positive) terminal on vehicle battery. Connect the black (negative) clamp to a ground on vehicle frame. Vehicle engine is turned OFF. The ATX-2 **10 ft black and red hoses must be disconnected from the transmission**. READY light is off.
2. Couple any fitting adapter to the end of the **10 ft red hose (right side of ATX-2)**. Place end of hose in bulk storage container for later use.
3. Press the EMPTY NEW button on the keypad.
4. Buzzer will sound and new transmission fluid will empty from the new tank inside the ATX-2 to the bulk storage container. Level can be viewed through the Level Indicator on the right side of the ATX-2.
5. Procedure will run until new tank is completely emptied or the STOP button is pressed. If process is allowed to run until completion (30 seconds after new fluid tank is empty), the buzzer will sound continuously and the PROCESS COMPLETE light will stay illuminated until the STOP button is pressed.
6. Disconnect fitting adapter from end of the 10 ft red hose.

# MAINTENANCE

The ATX-2 will provide many years of reliable service if properly maintained. The following checklist will ensure that the ATX-2 will run at peak efficiency and present an image to your customers that your shop performs high tech transmission services.

1. Use tool tray for storage of tools and adapters only.
2. Keep the exterior surface clean. Use a mild all purpose cleaner to wipe transmission fluid and dirt off the cabinet.
3. Do not allow the unit to sit outside in direct sunlight or inclement weather. Excessive exposure to sunlight or moisture will cause serious damage and will void the warranty.
4. The ATX-2 is not intended for mobile use where the unit is transported to customer sites. Excessive vibration will shorten component life, affect accuracy of performance and void the warranty. If the ATX-2 needs to be transported by vehicle, remove all fluid, in both the new and used tanks, prior to transport.
5. Be gentle when moving the ATX-2 around the shop. Tip the unit and ease the front casters over any obstacles such as door jams, air hoses and floor irregularities.
6. Periodically check all internal (by lifting out the tool tray) and external hoses for leaks or excessive wear. Any weak hoses should be replaced immediately to avoid possible injury.
7. Check the four filter screens (Item 4 and 6 on Page 15) often to avoid any blockage that may occur. Clean out debris or replace the filter screen if necessary.
8. Check air pressure in rear tires periodically (should be 30 psi), add air if needed.

## **Calibration - A Good Practice**

The ATX-2 is the most accurate of all transmission fluid exchange equipment due to the advanced load cell technology designed into the unit.

Most operating problems are usually fixed by performing a simple calibration procedure.

A good practice is to periodically calibrate the ATX-2 to ensure optimum performance.

The following pages describe the reasons for calibration and the actual calibration procedure.

Precision calibration weight(s) are included with the ATX-2.

# ATX-2 Calibration

The ATX-2 is a high-tech, electronically controlled machine for exchanging transmission fluid. The ATX-2 is connected in series with the transmission fluid flow at the cooler hose. The vehicle transmission pump then pumps used fluid into the ATX-2 used fluid tank and the ATX-2 pumps new fluid to the transmission from the tank of new fluid in the ATX-2. Transmission pumps vary in their flow rate from vehicle manufacturer to manufacturer. This requires that the ATX-2 monitor the old fluid coming from the transmission and then pump new fluid back to the transmission at the same rate.

The used and new fluid tanks in the ATX-2 each sit on a weight scale (load cell). The increasing weight of used fluid is monitored by the electronic controller which in turn controls the speed of the ATX-2 pump which is pumping new fluid to the transmission.

So, the function of the ATX-2 is to pump new fluid into the transmission as the transmission pumps out used fluid at a rate that will keep the transmission fluid level consistent. Not too much and not too little. This occurs with the design of the ATX-2 in a near-perfect world. So, what is the real world?

Real world conditions must be considered:

- 1) Not all new transmission fluids weigh exactly the same. They are very close.
- 2) Old transmission fluids can have different weights. Very old fluid can have a lot of solids suspended in the fluid and be very heavy.
- 3) Not all transmissions pump or control the flow of fluid in the same way. Some are very slow. Others cycle the flow of fluid off and on to the cooling lines dependent on the temperature of the fluid. Both of these examples might make the technician think the ATX-2 is not operating correctly because it takes so long to do the exchange. The procedure can be speeded up by accelerating the engine to 2000 RPM during the exchange.

These real world inconsistencies are expected and therefore the add or remove ½ quart feature was built into the ATX-2.

Slots are provided on the sides of the ATX-2 so that the technician can see the fluid levels in the tanks. The scales next to the slots **approximately** indicate the number of quarts in the tanks. The only purpose of these slots is to give the technician an idea of when the used fluid tank might need to be emptied or how many bottles of new fluid to bring from the supply room to fill the new fluid tank.

**Calibration of BOTH load cells is required when:**

1. **REMOVE USED FLUID** flashes and three beeps are heard when trying to select amount of fluid to be exchanged. The level of fluid in the used fluid tank is observed to be such that the tank is not full or would not fill to capacity during an exchange procedure. For example, **8 QUARTS** is pressed and there is obviously room in the used fluid tank to accept 10 or more quarts.
2. **ADD NEW FLUID** flashes and three beeps are heard when trying to select amount of fluid to be exchanged. For example, **8 QUARTS** is pressed and more than 10 quarts of fluid can be seen in the new fluid tank.
3. **REMOVE USED FLUID** flashes continuously.
4. **ADD NEW FLUID** flashes continuously.
5. The control board is replaced for any reason.

# CALIBRATION OF LOAD CELLS

The ATX-2 has two tanks, each mounted on a load cell. One tank is for new fluid and one is for used fluid. Each tank is **permanently bolted** to a load cell platform which can not be removed from the unit. The calibration procedure below must be performed for **both** load cells.

**Never calibrate only one load cell as an imbalance may occur and the ATX-2 will not operate correctly.**

1. Remove the rear panel.
2. Connect an adapter fitting to the 8 ft black hose. Place the end of the hose into a collection container.
3. Press and hold **4 QUARTS** and **20 QUARTS** buttons until a long beep is heard.
4. Select which load cell is to be calibrated.
  - a) Press **-1/2 QUART** to calibrate the used fluid load cell. **REMOVE USED FLUID** will be flashing throughout the remaining steps. A short beep will be heard.
  - b) Press **+1/2 QUART** to calibrate the new fluid load cell. **ADD NEW FLUID** will be flashing throughout the remaining steps. A short beep will be heard.

The pump will run and empty the contents of the selected tank through the 8 ft black hose into the collection container.

5. Press the **STOP** button when fluid is no longer leaving the machine through the black hose and the selected tank is empty. The pump will stop running. The **4 QUARTS** will be flashing. A short beep will be heard. Check that the tank is empty.
6. Press the **STOP** button again. The **12 QUARTS** will be flashing. A short beep will be heard. This programs the minimum weight.
7. Place two 5 kg or one 10 kg calibration weight on the top of the selected tank. (10 kg = 22 lbs)
8. Press the **STOP** button. The **12 QUARTS** will be illuminated. A short beep will be heard. This programs the maximum weight.
9. Remove calibration weight(s) and replace rear cover.
10. Press the **STOP** button again. A short beep will be heard. The machine returns to regular operating mode.

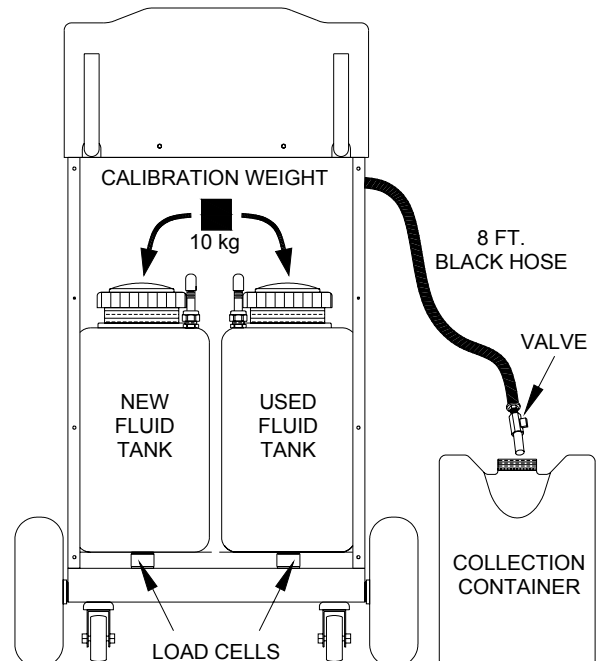

# PARTS IDENTIFICATION ATX-2

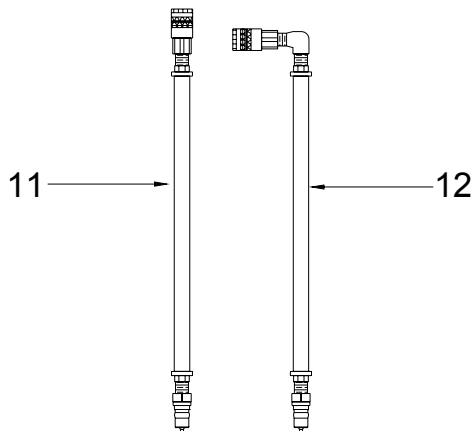
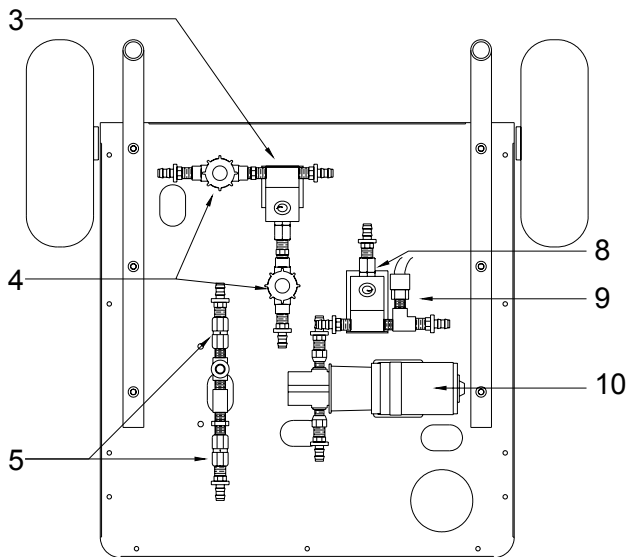
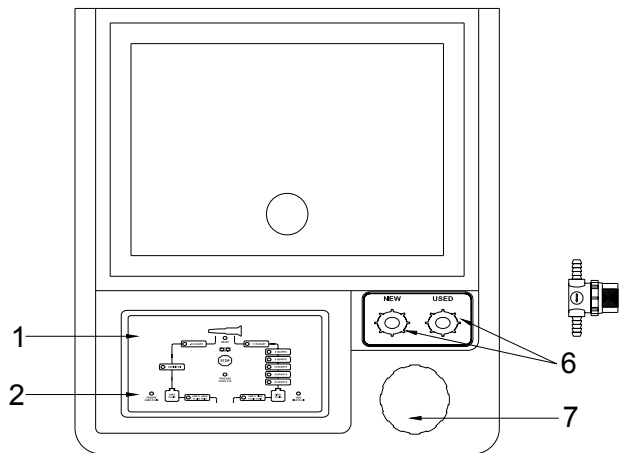

	Part No.	Description
1	024-80077-00	Keypad Overlay ATX-2
2	024-80079-00	Circuit Board ATX-2 (12VDC)
3	025-80331-00	3-Way Solenoid 0.650CV 1/4 FPT (12VDC)
4	026-80250-00	Sight Glass 1/4" FPT w/screen
	026-80248-00	Filter Mesh Cylinder 80 SS
5	022-80112-00	Check Valve 1/4 FPT X 1/4 FPT (Viton)
6	026-80247-00	Glass Sight 3/8" Barb Plastic w/clear Bowl
	026-80248-00	Filter Mesh Cylinder 80 SS
7	021-80164-00	Deck Fill Assy ATX
8	025-80332-00	3-Way Solenoid 0.135CV 1/4 FPT (12VDC)
9	022-80111-00	Pressure Switch 4-6 psig SPST
10	026-80245-00	Pump Gear .33 GPM 12VDC
11	300-80014-00	Hose Assy Straight
12	300-80015-00	Hose Assy 90 Degree
13	300-80038-00	New Fluid Tank Assy ATX-2
14	300-80040-00	Used Fluid Tank Assy ATX-2
15	031-80002-00	Load Cell 35 Kg

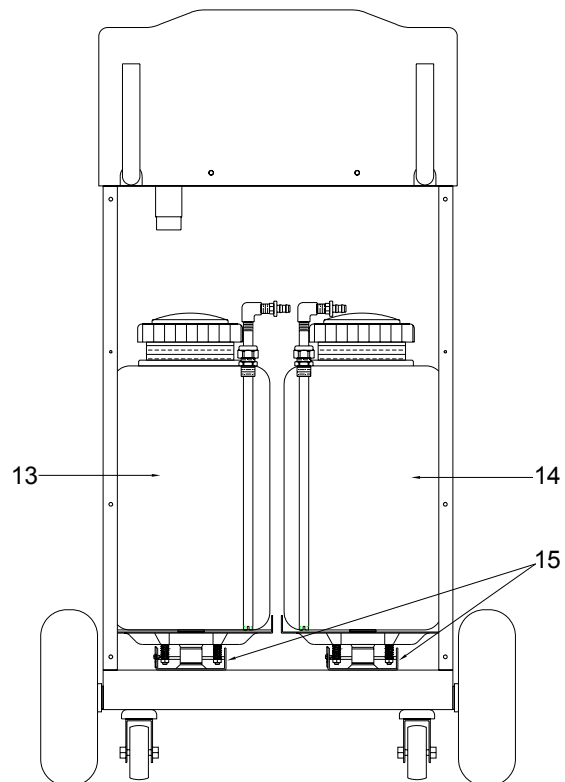

# FLOW & WIRING DIAGRAM

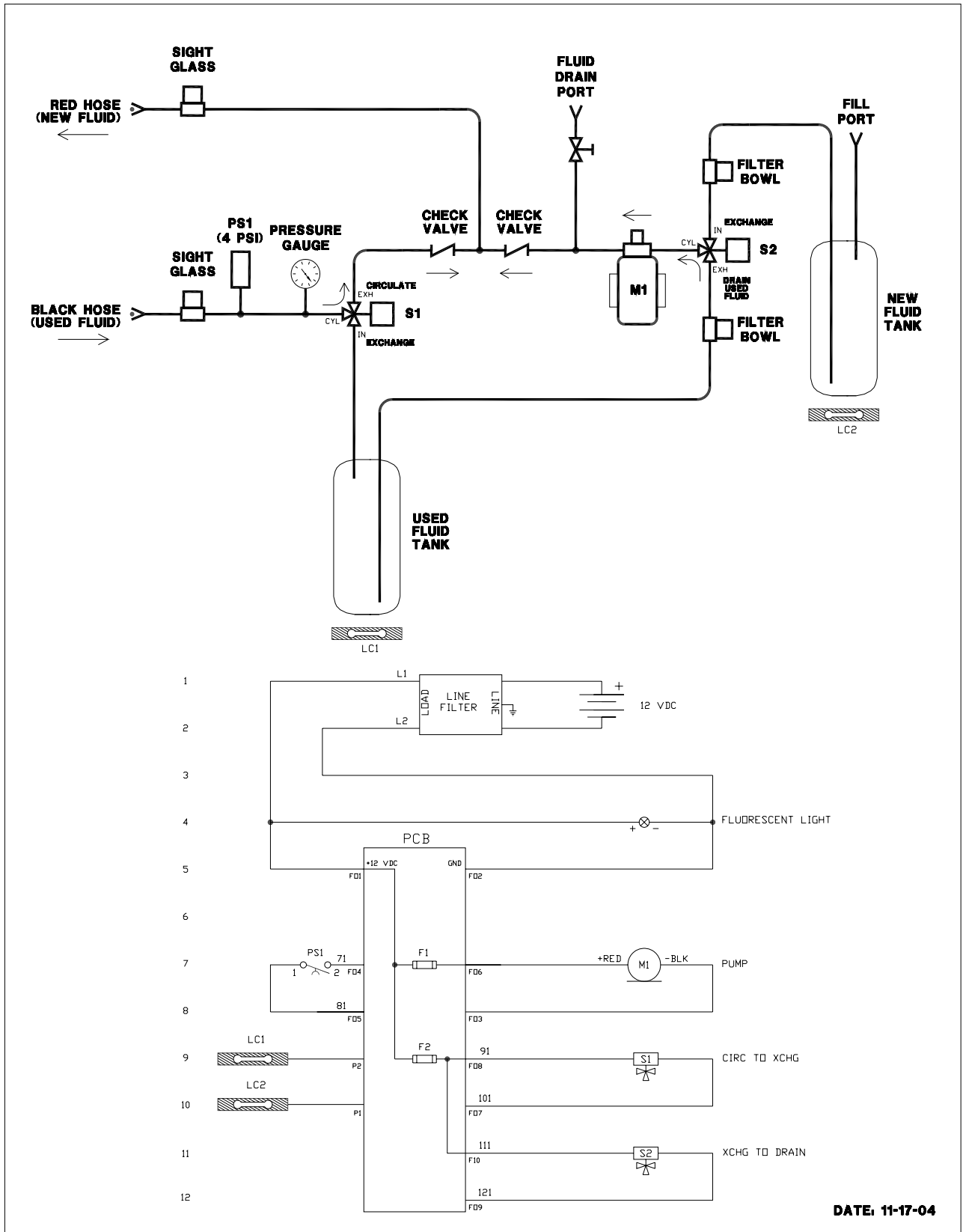

DATE: 11-17-04