

# OPERATION MANUAL

## BFX-2V

### Brake Fluid Exchanger



#### IMPORTANT

**Test drive vehicle after service to verify proper brake system performance.**



**RTI Technologies, Inc.**  
10 Innovation Drive  
York, Pennsylvania 17402 USA  
Phone: 800-468-2321  
Web-site: [www.rtitech.com](http://www.rtitech.com)

035-81260-00

# Table of Contents

Safety Precautions .....	1
Components .....	2
System Priming .....	3
Exchange Brake Fluid .....	4
Displays Indicating Action Required .....	7
Empty Used Fluid Tank .....	8
Filter Maintenance .....	8
Parts Identification .....	9
Flow Diagram & Electrical Schematic .....	10
EC Declaration of Conformity for Machinery .....	11

## Safety Precautions

**WARNING: Failure to follow these precautions can result in serious injury or death.**

- Read and understand the Operation Manual completely before operating this unit.
- Always wear proper eye and skin protection when operating and maintaining this equipment.
- Only disassemble or reassemble unit parts when directed by an RTI representative.
- Clean any spills that may occur immediately. Brake fluid is corrosive and is a high slip hazard.
- Avoid exposure with painted surfaces. Brake fluid is corrosive and will damage the finish on most painted surfaces. Use of fender covers is recommended.
- Always use vehicle specified brake fluid. Failure to do so may cause brake system damage. The BFX is designed to use DOT 3 or 4 brake fluid. Use of any other fluid type is not recommended and may void warranty.
- Comply with local, state and federal regulations for fluid disposal.
- **Material Safety Data Sheets** (MSDS) must be obtained on all chemicals and placed in a shop file for reference. Note: MSDS can be found on the RTI web site [www.rtech.com](http://www.rtech.com).
- It is important to test drive every vehicle after the service to verify proper brake system operation. Failure to do so could result in undetected brake system failure.

**CAUTION:** Failure to follow the precautions as outlined in the Operation Manual can result in damage to the engine, vehicle or equipment which will not be supported or covered under warranty.

# Components

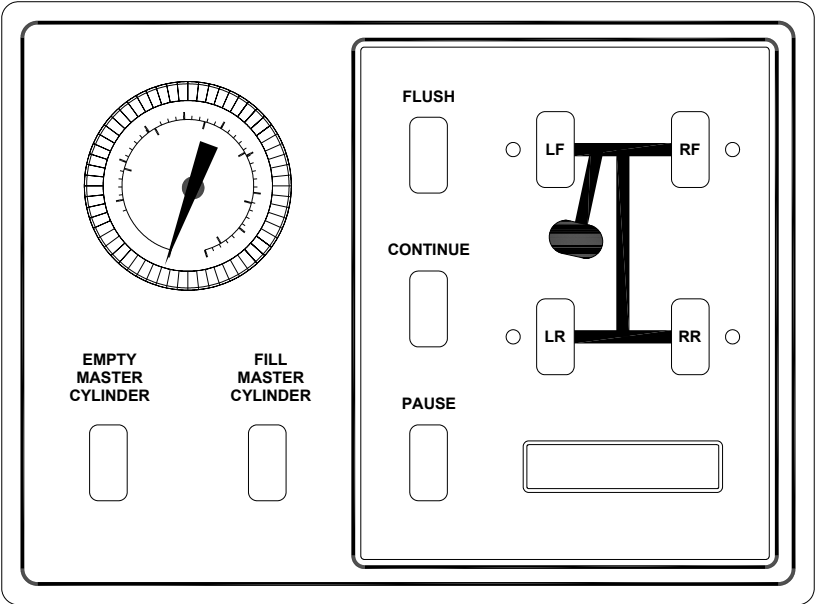

560-80379-00



# System Priming (First Time Use Only)

**Note:** System Priming is only necessary before the first time use of the BFX.

Connect red (positive) clamp on power cable to red (positive) terminal on vehicle battery. Connect the black (negative) clamp to a **good** ground. A good ground can be located by following the negative cable from the battery to where it is connected to the chassis.

**Warning:** Handle battery connection cable with extreme caution. Batteries generate explosive gases during normal operation. Working in the vicinity of a lead-acid or other automotive battery is dangerous. Wear eye protection. Never smoke or allow a spark or flame in the vicinity of the battery. Do not connect the black power clip to the negative post of the battery to avoid a spark.

R	T	I	T	E	C	H	N	O	L	O	G	I	E	S
				B	F	X	-	2	V					

← This will display for five seconds.

Buzzer will beep once. All LED's will blink on briefly.

N	E	W	T	A	N	K	=	#	#	O	Z	
S	E	L	E	C	T	P	R	O	C	E	S	S

← This will display.

Connect Fill Gun to Fill Hose.

Disconnect coupler on Used Fluid Tank and remove cap.

Press FILL MASTER CYLINDER.

Buzzer will beep three times.

N	E	W	T	A	N	K	E	M	P	T	Y	
S	C	A	N	N	E	W	B	O	T	T	L	E

← This will display.

Swipe bar code on new bottle of Valvoline Brake Fluid. Each bottle can only be scanned once (the BFX records the bar code number and will prevent a second scan). Buzzer will beep once when valid bar code is read by scanner.

I	N	S	T	A	L	L	B	O	T	T	L	E		
P	R	E	S	S	>	C	O	N	T	I	N	U	E	<

← This will display.

Install New Fluid Float Switch in bottle of brake fluid.

Press CONTINUE.

R	E	M	A	I	N	I	N	G		=	#	#		O	Z
F	I	L	L	I	N	G		M	C						

← This will display.

Place nozzle of Fill Gun into the Used Fluid tank and squeeze trigger.

Remaining ounces will be displayed and when zero will stop the process.

Press FILL MASTER CYLINDER to stop the process.

Release trigger. Replace cap on Used Fluid Tank and connect coupler.

N	E	W		T	A	N	K			=	#	#		O	Z
S	E	L	E	C	T		P	R	O	C	E	S	S		

← This will display.

## Exchange Brake Fluid

**BEFORE SERVICE:** Verify that the brake system does not have any malfunctions. If the system is found to be malfunctioning verify that the malfunction will not interfere with the exchange process. Perform all necessary repairs prior to fluid exchange.

Connect red (positive) clamp on power cable to red (positive) terminal on vehicle battery. Connect the black (negative) clamp to a **good** ground. A good ground can be located by following the negative cable from the battery to where it is connected to the chassis.

**Warning:** Handle battery connection cable with extreme caution. Batteries generate explosive gases during normal operation. Working in the vicinity of a lead-acid or other automotive battery is dangerous. Wear eye protection. Never smoke or allow a spark or flame in the vicinity of the battery. Do not connect the black power clip to the negative post of the battery to avoid a spark.

R	T	I		T	E	C	H	N	O	L	O	G	I	E	S
				B	F	X	-	2	V						

← This will display for five seconds.

Buzzer will beep once. All LED's will blink on briefly.

N	E	W	T	A	N	K		=	#	#		O	Z
S	E	L	E	C	T	P	R	O	C	E	S	S	

← This will display.

Press EMPTY MASTER CYLINDER.

N	E	W	T	A	N	K		=	#	#		O	Z
E	M	P	T	Y	I	N	G	M	C				

← This will display.

Use Vacuum Hose to remove all fluid from the master cylinder.

Press EMPTY MASTER CYLINDER to end the process.

IMPORTANT: Place end of Vacuum Hose on Parking Stud before proceeding to next step.

N	E	W	T	A	N	K		=	#	#		O	Z
S	E	L	E	C	T	P	R	O	C	E	S	S	

← This will display.

Connect Fill Gun to Fill Hose.

Press FILL MASTER CYLINDER.

Buzzer will beep three times.

N	E	W	T	A	N	K	E	M	P	T	Y		
S	C	A	N	N	E	W	B	O	T	T	L	E	

← This will display.

Swipe bar code on new bottle of Valvoline Brake Fluid. Each bottle can only be scanned once (the BFX records the bar code number and will prevent a second scan). Buzzer will beep once when valid bar code is read by scanner.

I	N	S	T	A	L	L	B	O	T	T	L	E		
P	R	E	S	S	>	C	O	N	T	I	N	U	E	<

← This will display.

Install New Fluid Float Switch in bottle of brake fluid.

Press CONTINUE.

R	E	M	A	I	N	I	N	G		=	#	#		O	Z
F	I	L	L	I	N	G	M	C							

← This will display.

Place nozzle of Fill Gun into the Master Cylinder and squeeze trigger. Remaining ounces will be displayed.

Release trigger when master cylinder is filled to proper level.

Press FILL MASTER CYLINDER to stop the process.

Hold Fill Gun over Master Cylinder and squeeze trigger to relieve pressure.

Replace Master Cylinder cap and disconnect Fill Gun.

N	E	W		T	A	N	K		=	#	#		O	Z
S	E	L	E	C	T		P	R	O	C	E	S	S	

← This will display.

Select correct Master Cylinder Adapter and install on the Master Cylinder.

Connect Fill Hose to Master Cylinder Adapter.

Press Fill Master Cylinder and check that adapter is sealed and there are no leaks.

Press Fill Master Cylinder to stop the process.

Raise vehicle to comfortable level to access the brake bleeder valves. Use caution to not disconnect power cable from battery or put strain on the Fill Hose connected to the Master Cylinder.

Connect a Bleeder Hose to each brake bleeder valve. Match colors on Bleeder Hoses to the control panel graphic.

Press FLUSH.

E	N	T	E	R		S	E	Q	U	E	N	C	E	
X	X	-	X	X	-	X	X	-	X	X				

← This will display.

Press LF, RF, LR and RR in sequence desired during the sequential brake fluid exchange. The order pressed should be according to the recommended sequence as specified by the manufacturer for the particular vehicle.

The order entered will be displayed.

Press CONTINUE.

O	P	E	N		B	L	E	E	D	E	R	S			
P	R	E	S	S		>	C	O	N	T	I	N	U	E	<

← This will display.

Open all bleeder valves.

Press CONTINUE.

R	E	M	A	I	N	I	N	G		=	#	#		O	Z
B	L	E	E	D	I	N	G		X	X					

← This will display.

This display will show each bleeder as fluid is exchanged.

P	R	E	S	S		>	C	O	N	T	I	N	U	E	<
C	L	O	S	E		B	L	E	E	D	E	R	S		

← This will display.

Buzzer will beep every 20 seconds to indicate procedure is complete.

Press CONTINUE and then close bleeders.

P	R	E	S	S	>	F	L	U	S	H	<			
W	H	E	N		F	I	N	I	S	H	E	D		

← This will display.

When all bleeders have been closed press FLUSH.

C	L	E	A	R	I	N	G		P	R	O	C	E	S	S
R	U	N	N	I	N	G	,		W	A	I	T			

← This will display.

When the clearing process is complete the next screen will be displayed.

N	E	W		T	A	N	K		=	#	#		O	Z	
S	E	L	E	C	T		P	R	O	C	E	S	S		

← This will display.

Remove Master Cylinder Adapter and check fluid level.

Press EMPTY MASTER CYLINDER to remove fluid if required.

Pour in fluid from new fluid bottle if required.

## Displays Indicating Action Required

U	S	E	D		T	A	N	K		F	U	L	L		
M	U	S	T		B	E		E	M	P	T	I	E	D	

← This will display if the tank which holds used fluid fills to capacity.

Refer to instructions for emptying the Used Fluid Tank on the next page.

N	E	W		T	A	N	K		E	M	P	T	Y		
S	C	A	N		N	E	W		B	O	T	T	L	E	

← This will display if the level of fluid is too low in the bottle of new fluid.

A new bottle must be scanned and connected.

# Empty Used Fluid Tank

1. Disconnect the fluid line coupler and the electrical float switch cable on the Used Fluid Tank.
2. Remove cap on Used Fluid Tank (turn counterclockwise).
3. Empty used fluid into an appropriate bulk waste container.
4. Replace cap on Used Fluid Tank (turn clockwise).
5. Connect fluid line coupler and the electrical float switch cable.

**Follow all federal and local laws and regulations when disposing of hazardous material.**

## Filter Maintenance

The BFX-2V has six filters to prevent debris from entering internal components.

**New Fluid Filter:** Filters fluid from the New Fluid Bottle. If the fluid flow seems slow while trying to fill the master cylinder - check and clean this filter.

This filter can be accessed through the front door on the top of the BFX-2V. Remove screws and gently raise the door to access the filter.

Unscrew the filter cover and clean the screen as required.

**Vacuum Filter:** Filters fluid in the five vacuum hoses. A filter is mounted in-line on each of the hoses. If the fluid flow seems slow from the bleeders - check and clean these filters.

These filters can be accessed through the rear door on the top of the BFX-2V. Remove the two thumb screws and lift the door. The filters will be seen about 12 inches below where the hoses go through the panel inside. Remove hoses from both ends of the filter and try clearing the filter with compressed air.

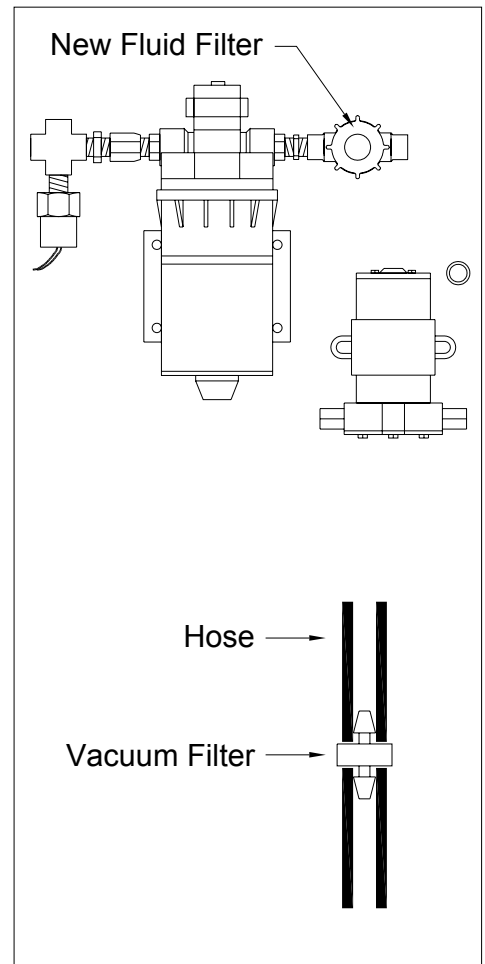

560-80379-00

# Parts Identification

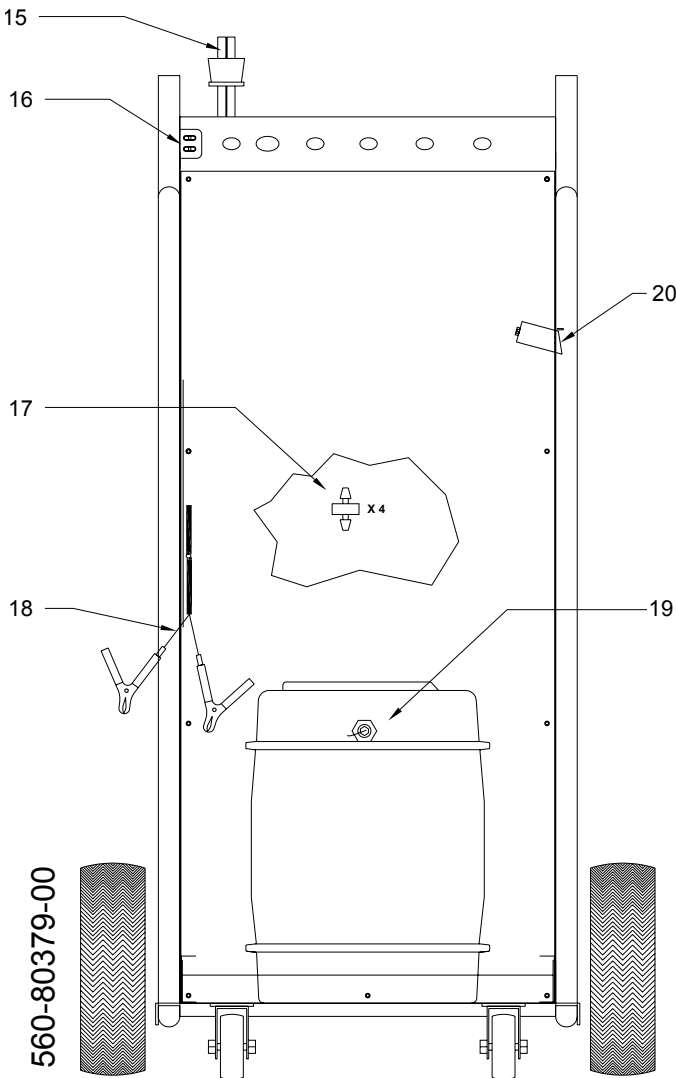
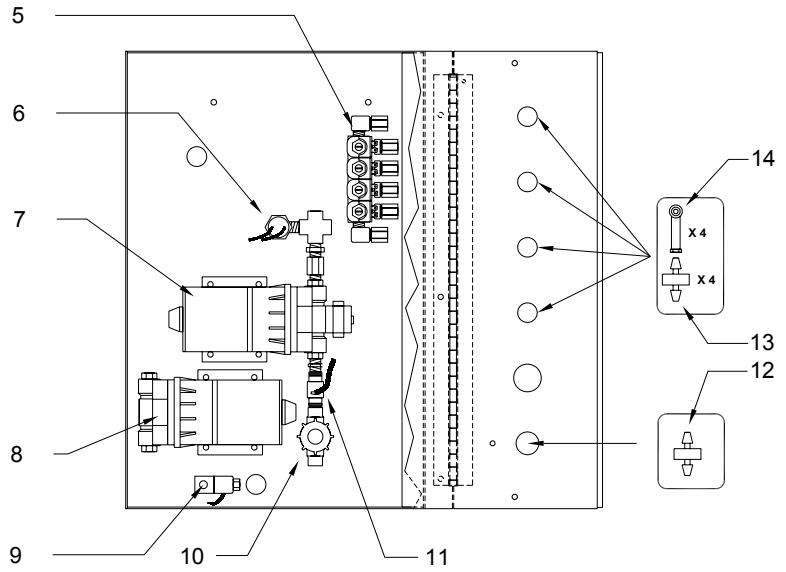
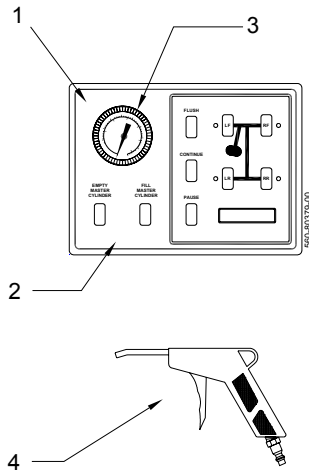

	Part Number	Description
1	024-80106-00	Keypad Overlay
2	024-80107-00	Circuit Board
3	325-80048-00	Pressure Gauge Assy
4	325-80002-00	Wand Assembly
5	025-80361-00	Manifold 4 Valve 12 VDC 1/4FPT
6	325-80057-00	Pressure Switch 14-17 psi SPST
7	325-80029-00	Supply Pump (with terminals)
8	325-80034-00	Vacuum Pump (with terminals)
9	325-80044-00	Solenoid S5 Assembly
10	026-80389-00	Sight Glass FPT (Nylon)
11	325-80042-00	Flow Sensor Assy (with terminals)
12	026-80325-00	Filter Inline 1/4 Barb 150 Micron
13	022-80133-00	Check Valve 3/16 Barb Nylon
14	023-80344-00	Adapter Brake Nipple x 3/16 Barb
15	024-80099-00	Float Switch Assy for New Bottle
16	025-80364-00	EMI Filter 16A
17	026-80372-00	Filter Inline 3/16 Barb 150 Micron
18	320-80005-00	Cord Power 14/2 Clamps 12 ft
19	325-80004-00	Used Tank Assembly
20	025-80370-00	Barcode Scanner

# Flow Diagram & Electrical Schematic

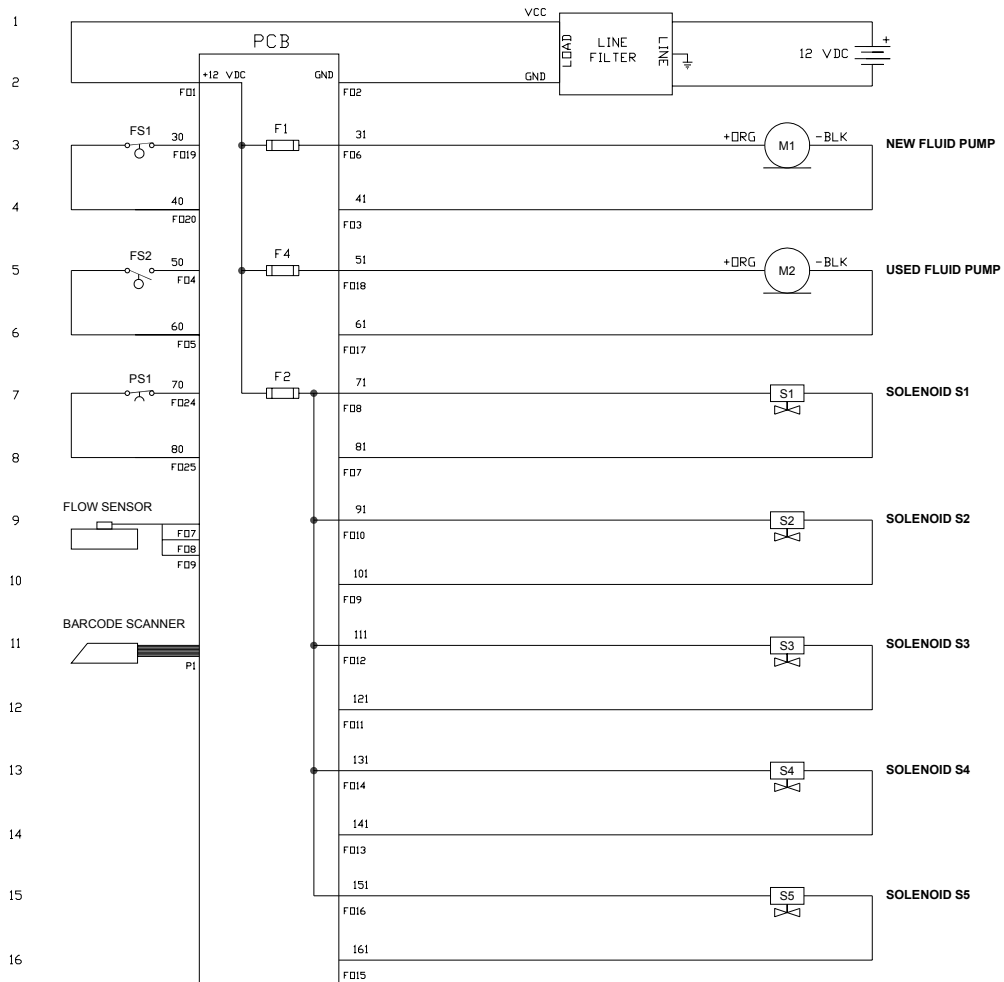
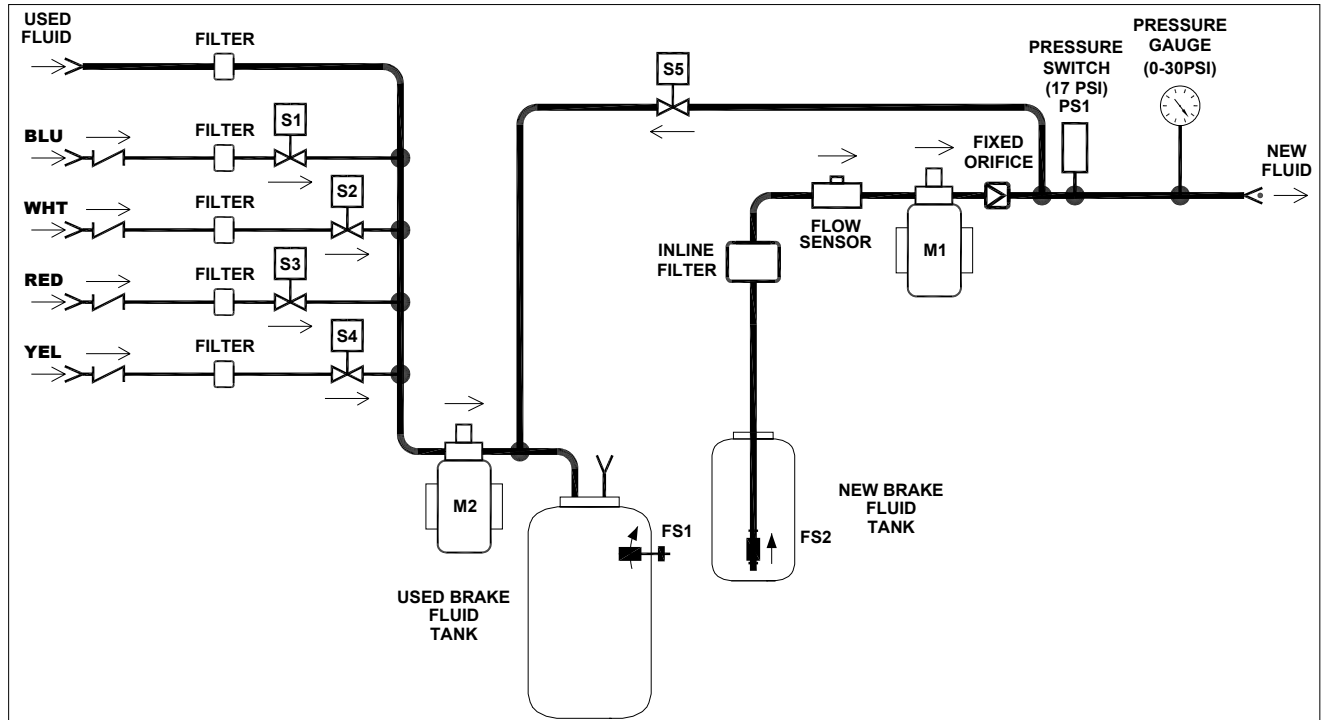

570-80312-00

DATE: 10-27-05

# EC Declaration of Conformity for Machinery

Directive 98/37/EC



**RTI Technologies, Inc.**

10 Innovation Drive  
York, Pennsylvania 17402 USA  
Phone: 717-840-0678

Herewith declares that:

- BFX-2V Brake Fluid Exchanger
- is in conformity with the provisions of the Machinery Directive (directive 98/37/EC) and with the national implementing legislation
- is in conformity with the provisions of the following other EC directives:

Electromagnetic Compatibility (EMC) Directive 89/336/EEC

Electromagnetic Emissions EN 61000-6-4: 2001

Electromagnetic Immunity EN 61000-6-2: 1999

The BFX-2V is certified to the EMC Directive like the ATX-2 tested by:

TÜV America Inc.  
1775 Old Highway 8 NW Ste. #104  
New Brighton, MN 55112  
Phone: 651-638-0262



Thomas L. Crandall

A handwritten signature in black ink that reads 'Thomas L. Crandall'.

Vice President - Technology

Dated: November 11, 2005