

# OPERATION MANUAL

## MCX-2S

Multiple Coolant Exchanger

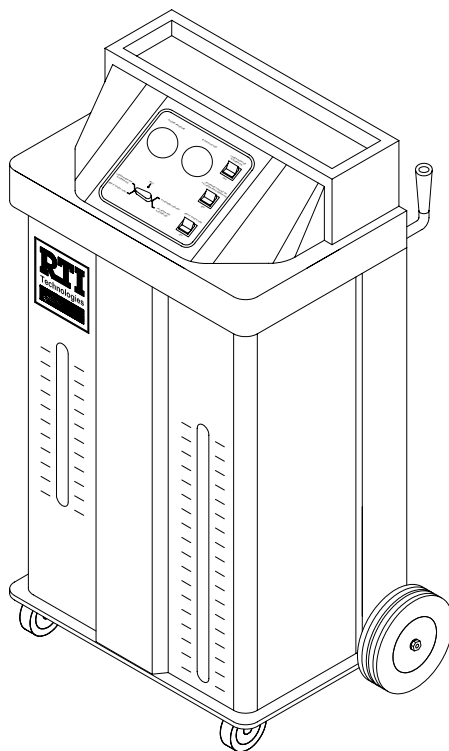

**RTI Technologies, Inc.**  
4075 East Market St.  
York, PA 17402 USA  
800-468-2321  
[www.rtitech.com](http://www.rtitech.com)



Manual Number 035-80863-00 (Rev G)

# TABLE OF CONTENTS

|  |    |
|--|----|
| Component Description . . . . .            | 2  |
| Safety Precautions . . . . .               | 3  |
| Operation of Valves . . . . .              | 3  |
| Set-up . . . . .                           | 4  |
| Relieving Radiator Pressure . . . . .      | 5  |
| Lowering Coolant Level . . . . .           | 6  |
| Connecting to the Coolant System . . . . . | 7  |
| Special Hookups . . . . .                  | 8  |
| Coolant Replacement . . . . .              | 9  |
| Test Coolant System for Leaks . . . . .    | 11 |
| Completing the Job . . . . .               | 12 |
| Changing Coolant Type . . . . .            | 14 |
| Emptying the Waste Tank . . . . .          | 16 |
| Replacement Parts . . . . .                | 17 |
| Waste Pump Impeller Replacement . . . . .  | 18 |
| Flow & Wiring Diagram . . . . .            | 19 |

**Technical Support: 800-468-2321**  
**Mon. - Fri. 8AM - 5PM (Eastern Time)**  
**Sat. - Sun. 8AM - 12PM (Eastern Time)**

# COMPONENT DESCRIPTION

Unpack all components and verify quantities per this illustration.

Contact RTI if any items are missing or damaged.

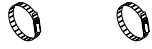

Small Hose Clamps



Small Adapter Hose

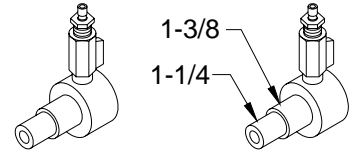

Small Step Adapters



Large Hose Clamps



Large Adapter Hose

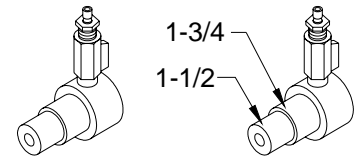

Large Step Adapters



Extra Large Hose Clamps

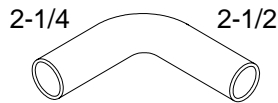

Extra Large Adapter Hose

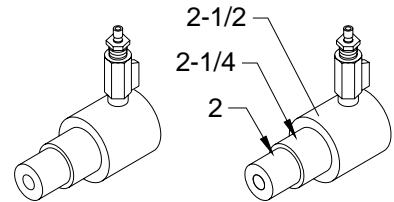

Extra Large Step Adapters

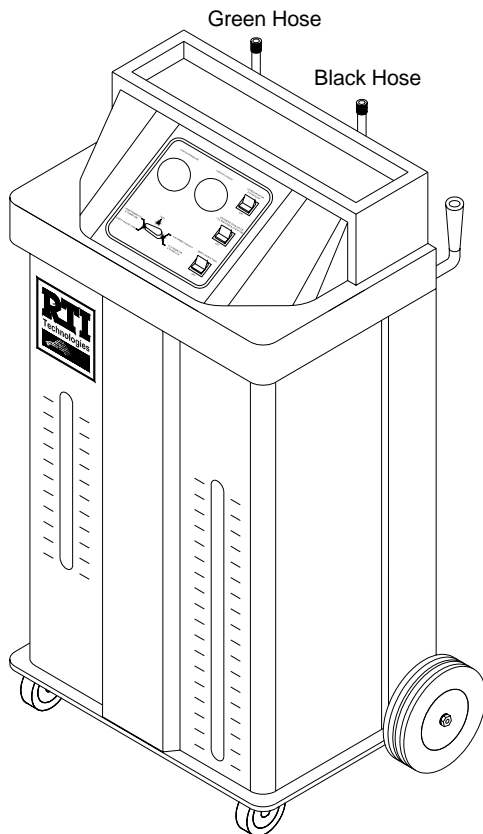

Level Magnets

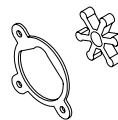

Impeller & Gasket

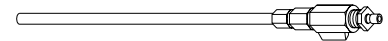

Wand

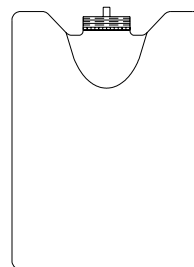

New Coolant Tank  
(Qty=3)



Waste Tank

# SAFETY PRECAUTIONS

**WARNING: FAILURE TO FOLLOW THESE PRECAUTIONS CAN RESULT IN SERIOUS INJURY OR DEATH.**

- Read and understand the Operation Manual completely before operating this unit.
- Always wear proper eye and skin protection when operating and maintaining this equipment.
- Take precautions to keep clothing, hair, hands, hoses, etc. away from all moving parts on the vehicle.
- Automotive cooling systems can be under pressure and extremely hot. Use extreme caution when removing caps and hoses.
- Coolants are poisonous to people and animals and are also corrosive. Clean up any spills immediately.

**CAUTION: FAILURE TO FOLLOW THE PRECAUTIONS AS OUTLINED IN THE OPERATION MANUAL CAN RESULT IN DAMAGE TO THE ENGINE, VEHICLE OR EQUIPMENT WHICH WILL NOT BE SUPPORTED OR COVERED UNDER WARRANTY.**

- Do not allow waste coolant tank to overflow. Immediately clean up any coolant spills. Damage to the vehicle and equipment can result from the corrosiveness of coolant.
- Continuous monitoring of the coolant replacement process is required.

## Operation of Valves

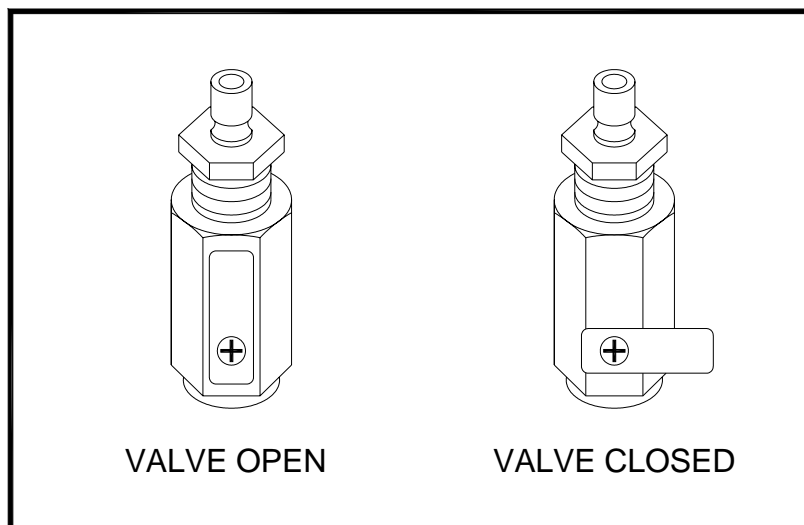

# SET UP

The MCX-2S was carefully packaged by RTI to arrive without damage. Report any evidence of damage immediately by calling RTI Technical Support at 800-468-2321.

Mon. - Fri. 8AM - 5PM (Eastern Time)

Sat. - Sun. 8AM - 12PM (Eastern Time)

Following are the steps required to prepare the MCX-2S for operation:

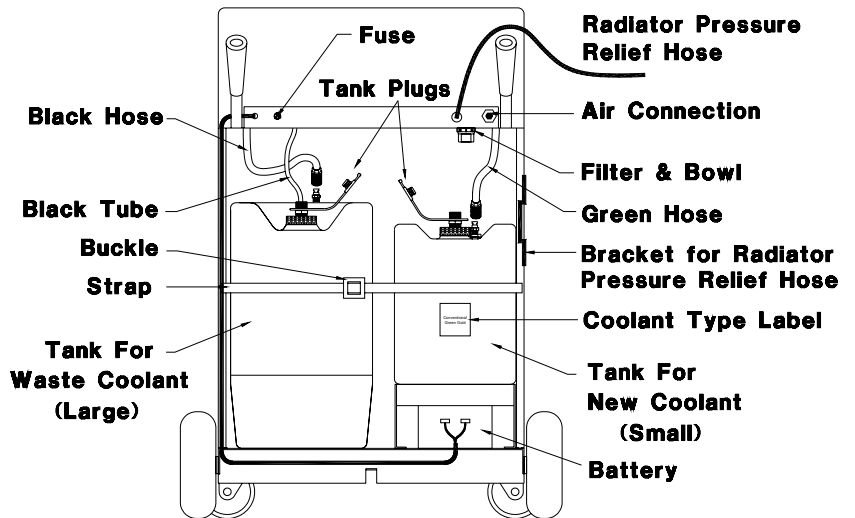

## REAR VIEW OF MCX-2S

1. Remove all packing materials. Press sides of buckle to release black web strap on rear of unit. Remove the tanks and the accessory cartons from their shipping position. There are three small New Coolant Tanks and one large Waste Coolant Tank.
2. Press down on the levers on the front casters to lock them. This will keep the MCX-2S from moving as tanks are installed and connected.
3. Labels are provided to attach to the new coolant tanks to identify the type of coolant. Peel off the protective backing cover and place the appropriate label on the narrow side of the new coolant tank. Attach the label on the side closest to the brass hose connection fitting and large fill cap.
4. Unscrew the large cap and fill one of the New Coolant Tanks with coolant and water. Refer to the specifications of the coolant manufacturer for the correct proportions of water and coolant. Replace the cap.
5. Pull the Tank Plug out of the port in the large cap. A strap keeps the plug handy for use when carrying the tank to other areas to avoid splashing.
6. Set the New Coolant Tank into the right side of the MCX-2S on the shelf above the Battery. The brass hose connection fitting should be closest to the **rear** of the MCX-2S. The coolant type label should be visible as shown above when the tank is positioned correctly.
7. Connect the Green Hose to the brass quick connect fitting on the New Coolant Tank. A sleeve on the hose fitting can be slid away from the end of the fitting to make connection and disconnection easy.
8. Set the Waste Coolant Tank into the left side of the MCX-2S. The Hose connection fitting should be closest to the **front** of the MCX-2S.
9. Connect the Black Hose to the quick connect fitting on the Waste Tank. A sleeve on the fitting can be slid away from the end of the fitting to make connection and disconnection easy.
10. Pull the Tank Plug out of the port in the large cap on the Waste Tank. A strap keeps the plug handy for use when carrying the tank to other areas to avoid splashing.
11. Insert the small diameter Black Tube into the hole in the large cap on the Waste Coolant Tank. This tube hangs above the Waste Tank. Do not pull on the hose. Do not confuse this tube with the Radiator Pressure Relief Hose on the upper right corner of the MCX-2S.
12. Press sides of buckle on strap and insert mating end of buckle to secure the tanks in place.
13. Lay the green and black hoses over the hose storage bracket on the rear of the MCX-2S. Wrap the Radiator Pressure Relief Hose on the bracket on the right side of the rear of the MCX-2S.
14. Install 12 volt battery (not supplied with unit) in lower right compartment. Set all selector switches to OFF. Connect cable using supplied hardware. Connect black terminal to negative (-) battery post and red terminal to positive (+) battery post.
15. Release the locks on the front casters by lifting up on the levers.
16. Refer to Page 2 and check that all accessory parts were received. The accessory parts are packed in cartons included with the MCX-2S.

# RELIEVING RADIATOR PRESSURE

**WARNING:** Coolant in the vehicle cooling system may be extremely hot and under great pressure. Wear safety glasses and use protective clothing and gloves. Use extreme caution when removing radiator cap and hoses.

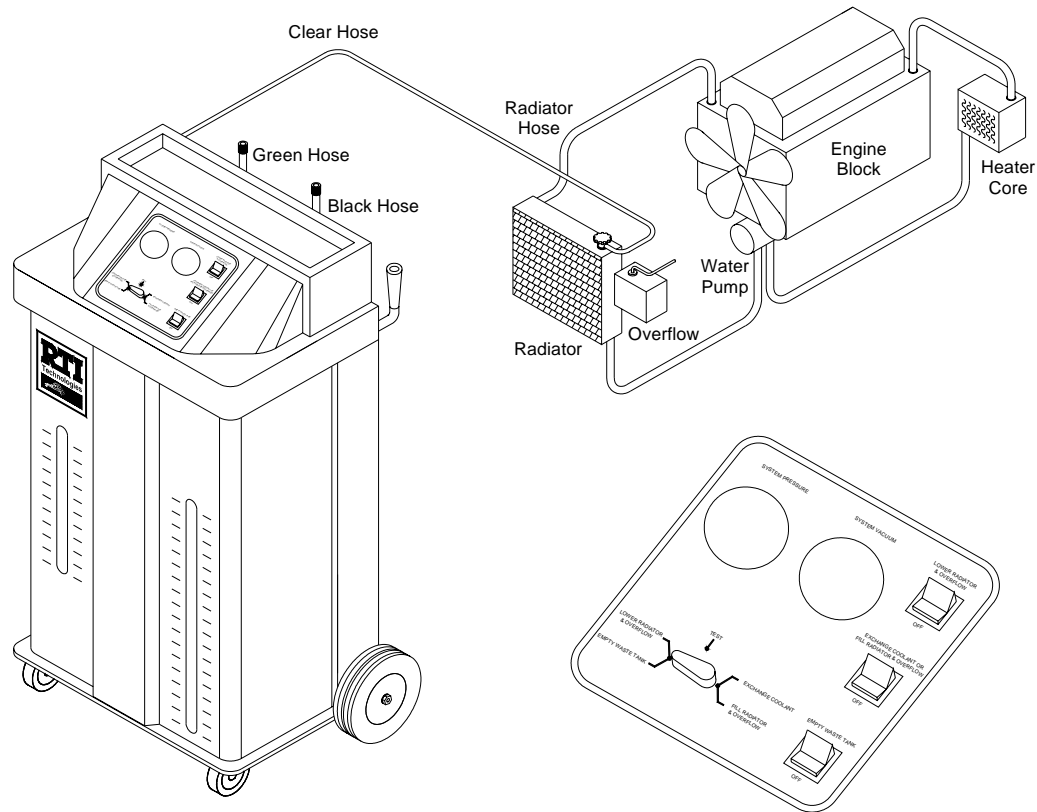

**NOTE:** The MCX-2S does not need to be connected to power for the following.

The MCX-2S will relieve the pressure in a hot-car radiator by drawing a vacuum on the overflow port on the radiator cap.

Connect shop air (55 to 100 PSI) to the port on the rear of the MCX-2S. This will cause a vacuum to be pulled on the small diameter clear hose, also connected to the rear. Connect clear hose to the overflow port on the radiator cap as shown above.

The system Vacuum Gauge on the MCX-2S control panel indicates the vacuum level which will increase until the radiator cap opens and relieves the pressure. As the pressure releases a small amount of coolant will be seen flowing in the clear hose. When the pressure has been relieved, the radiator cap will again close and the vacuum level will increase and become steady on the gauge.

The radiator cap can now be slowly and carefully removed.

Disconnect shop air from rear port.

# LOWERING COOLANT LEVEL

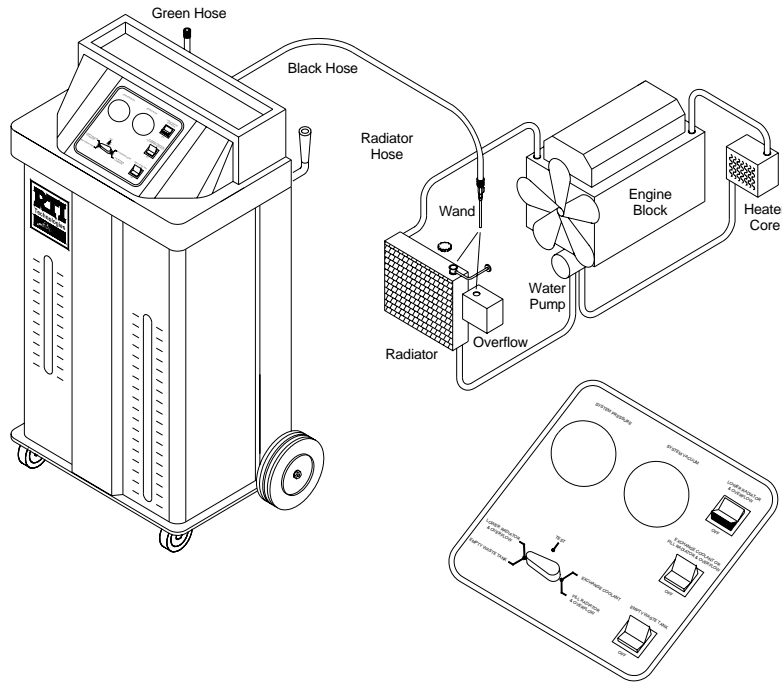

**WARNING: Coolant in the vehicle cooling system may be extremely hot and under great pressure. Wear safety glasses and use protective clothing and gloves. Use extreme caution when removing radiator cap and hoses.**

1. Slowly and carefully remove the cap from the radiator.
2. Remove cap from overflow container.
3. Attach the wand to the black hose. Close the valve.
4. Turn control valve to LOWER RADIATOR & OVERFLOW.
5. Press the top of LOWER RADIATOR & OVERFLOW selector switch to turn on pump.
6. Use the Wand to empty the overflow container and lower the level of coolant in the radiator to a level just below the upper hose connecting the radiator to the engine. Open valve on wand as required.

## VERY IMPORTANT

**Open valve on wand only while end is in fluid.  
Do not suck air as the pump may lose its prime**

7. Press bottom of LOWER RADIATOR & OVERFLOW selector switch to turn off pump.
8. Replace caps on the radiator and overflow container.

# CONNECTING TO THE COOLANT SYSTEM

The MCX-2S can be connected to the cooling system in either of the configurations shown below. The choice is dependent on the ease of accessibility to the hose connections.

1. Disconnect the radiator hose from either the engine or the radiator.
2. Select an Adapter Hose with the same inner diameter as the radiator hose and connect at the point the radiator hose was disconnected using a clamp.
3. Install Step Adapters in the Adapter Hose and the radiator hose using clamps. Make sure the outside diameter of the Step Adapters is the same as the inner diameter of the radiator hose.
4. Connect the Green and Black hoses from the MCX-2S to the two Step Adapters as shown in the illustrations. **See next page for special hookups.**
5. Open the valves on the two Step Adapters.

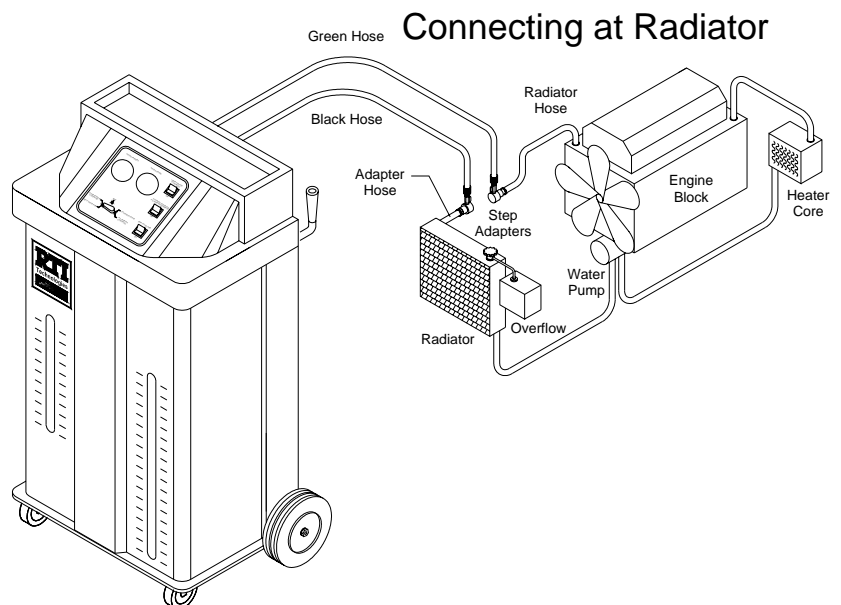
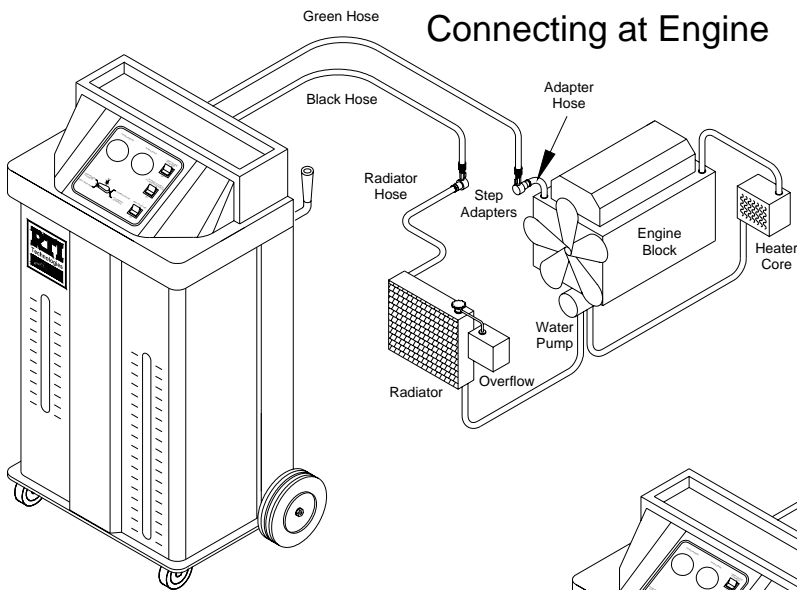

# SPECIAL HOOKUPS

Special Hookup 1) It may be necessary to reverse the hoses during the coolant replacement procedure on the following pages for systems with a reverse-connected thermostat. See note after Step 7 for the symptoms of this situation.

Special Hookup 2) Some cooling systems do not have a cap on the radiator. Instead, there is a single cap on the overflow tank as shown in the illustration below.

The hoses to and from the overflow tank must be pinched using hose pinching pliers during the coolant replacement procedure on the following pages.

Failure to pinch these hoses will cause fluid to be forced out of the vented cap on the overflow tank during the coolant replacement procedure.

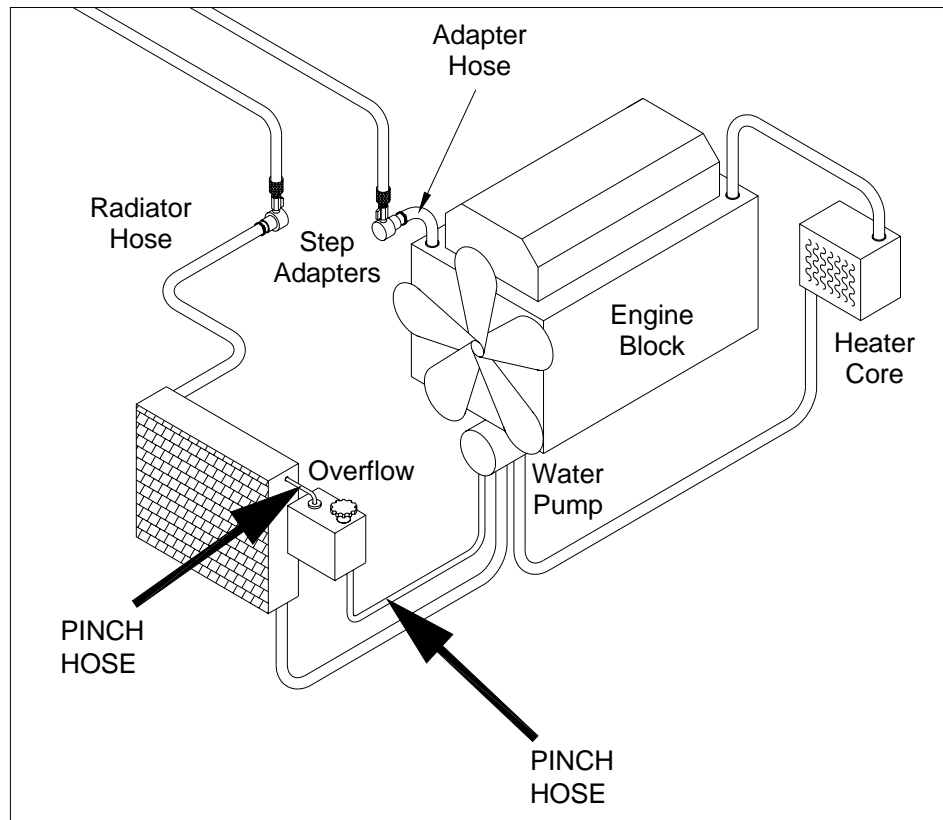

# COOLANT REPLACEMENT

Once the MCX-2S is connected as described on the preceding pages it is ready to replace the old coolant with new coolant.

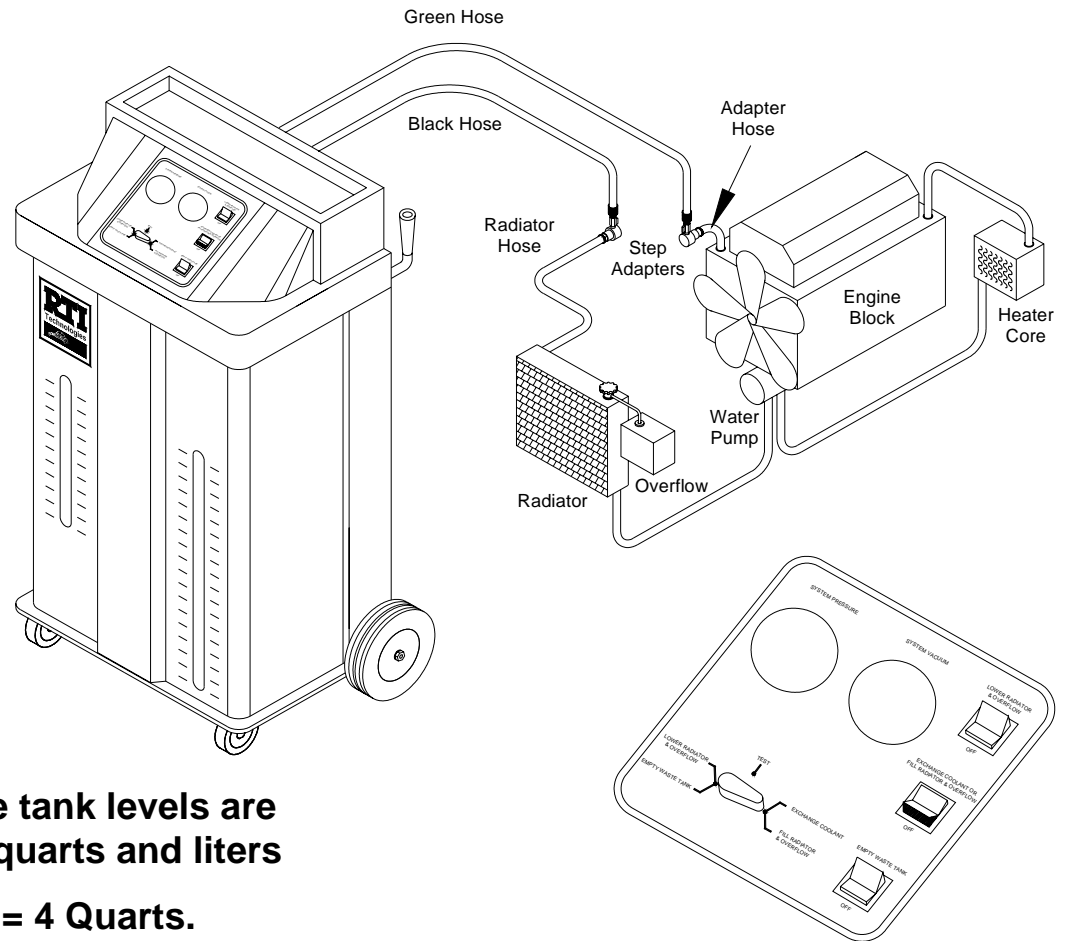

**Scales for the tank levels are graduated in quarts and liters**

**1 Gallon = 4 Quarts.**

1. Determine the capacity and type of coolant for the vehicle cooling system. Refer to the vehicle Owner's Manual.
2. Make sure the New Coolant Tank (left slot on front) is filled with the correct coolant and at a level higher than the amount required to fill the coolant system to full capacity.
3. Check the Waste Tank (right slot on front) to make sure the level is low enough to accept the full capacity of coolant in the vehicle cooling system.

**Continued on next page . . .**

# COOLANT REPLACEMENT

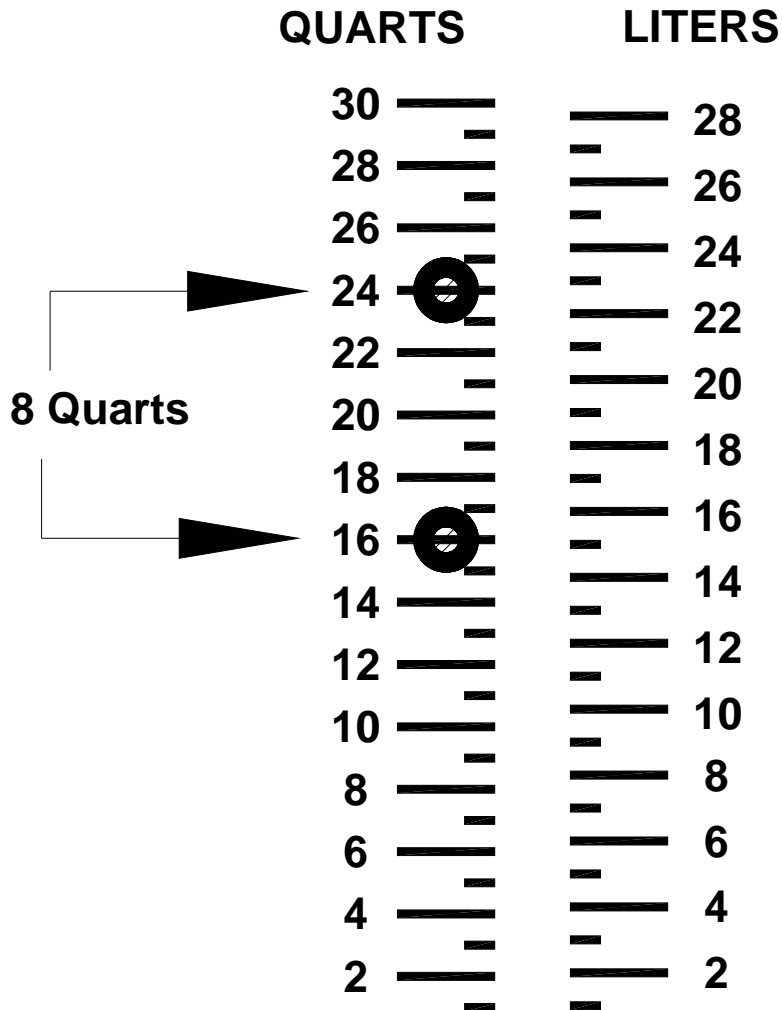

4. Set one of the Level Magnets at the fluid level in the New Coolant Tank (24 in above drawing). Determine the amount of coolant to be exchanged (8 Quarts for example) and position the other Level Magnet that many quarts below the other magnet (16 in above drawing).
5. Turn control valve to EXCHANGE COOLANT.
6. Press the top of EXCHANGE COOLANT OR FILL RADIATOR & OVERFLOW selector switch to turn on the pump.
7. Watch the level of coolant as it lowers in the New Coolant Tank. Press the bottom of the EXCHANGE COOLANT OR FILL RADIATOR & OVERFLOW selector switch when it reaches the lower Level Magnet. This will stop the transfer of coolant.

If the pump is running and the new coolant level does not go down:  
Try reversing the connections of the green and black hoses.

# TEST COOLANT SYSTEM FOR LEAKS

The MCX-2S can be used to check the coolant system for leaks. The coolant system is pressurized and the System Pressure Gauge on the MCX-2S is monitored for a drop in pressure which would indicate a system leak.

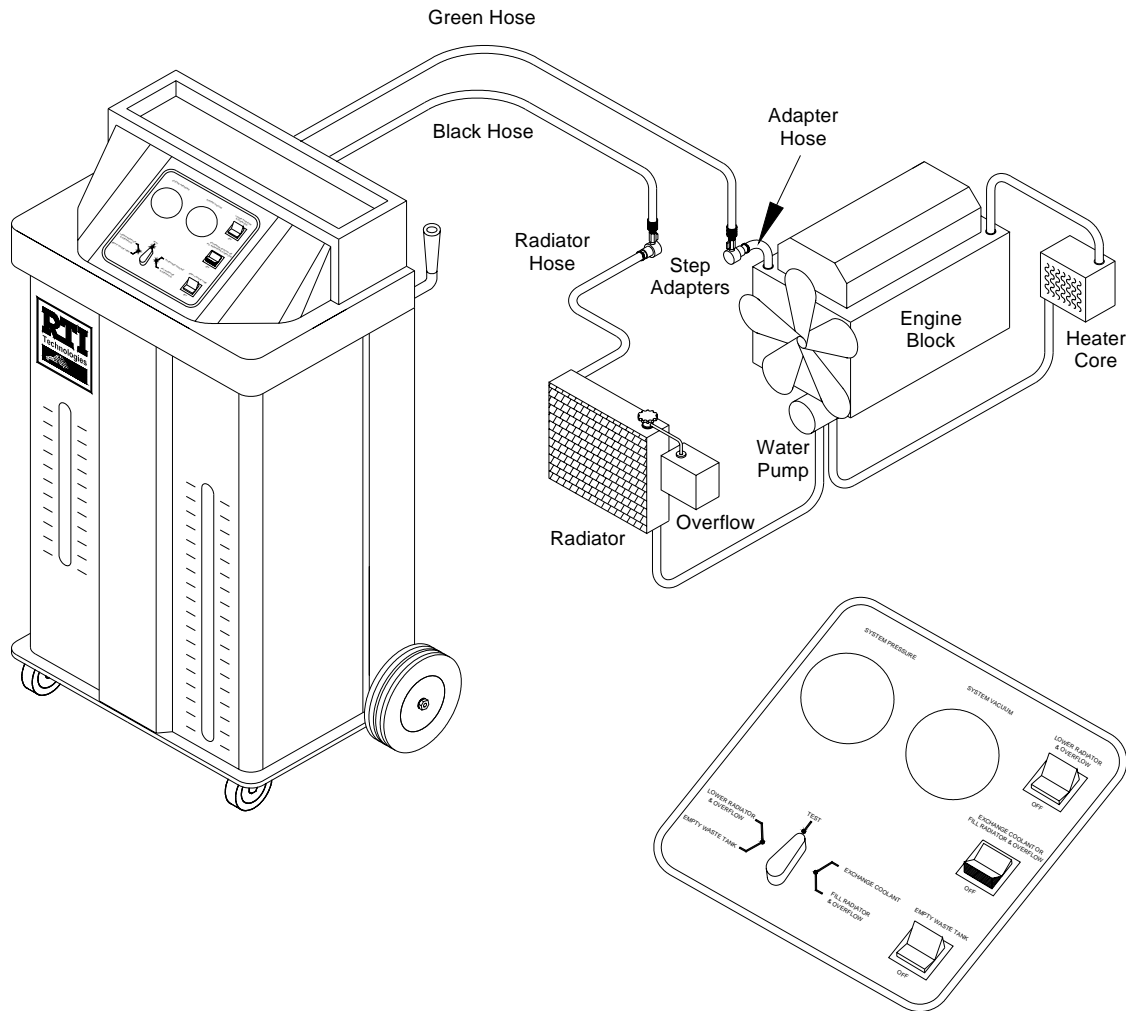

The MCX-2S should be connected as shown above.

1. Turn control valve to TEST.
2. Press the top of EXCHANGE COOLANT OR FILL RADIATOR & OVERFLOW selector switch to turn on the pump.
3. Watch the System Pressure Gauge and press the bottom of the EXCHANGE COOLANT OR FILL RADIATOR & OVERFLOW selector switch when the pressure reaches 10 to 13 PSI.
4. The coolant system is now pressurized. Monitor the pressure for a constant reading. A coolant system leak is indicated if the pressure falls.

# COMPLETING THE JOB

All used coolant in the vehicle cooling system has now been replaced with new coolant. The following steps will complete the job.

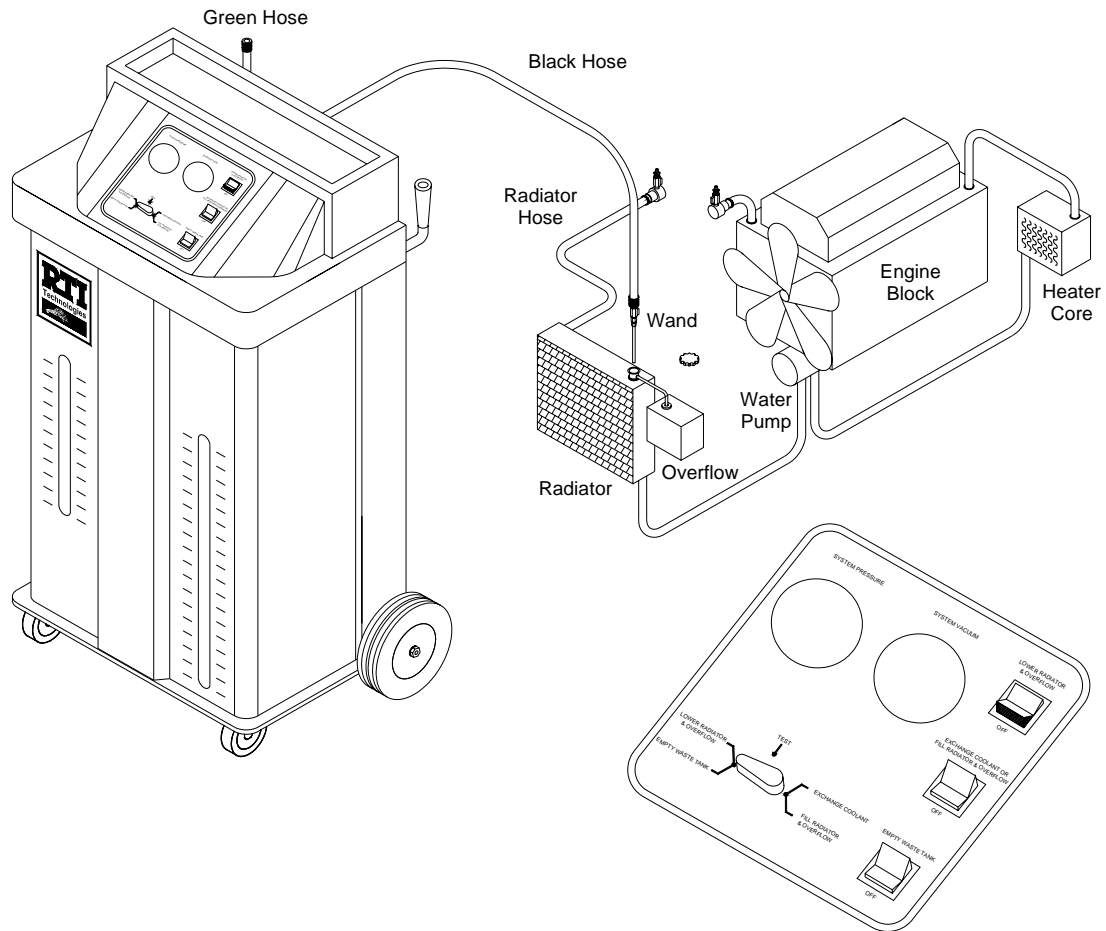

1. Close the valves on the Step Adapters.
2. Disconnect the black and green hoses from the Step Adapters.
3. Install Wand on black hose. Close the valve.
4. Remove the cap from the radiator.
5. Turn control valve to LOWER RADIATOR & OVERFLOW.
6. Press top of LOWER RADIATOR & OVERFLOW selector switch to turn on pump.
7. Use the Wand to lower the level of coolant in the radiator to a level just below the upper hose where the Step Adapter is attached. Open valve on Wand as required.

**Continued on next page . . .**

# COMPLETING THE JOB

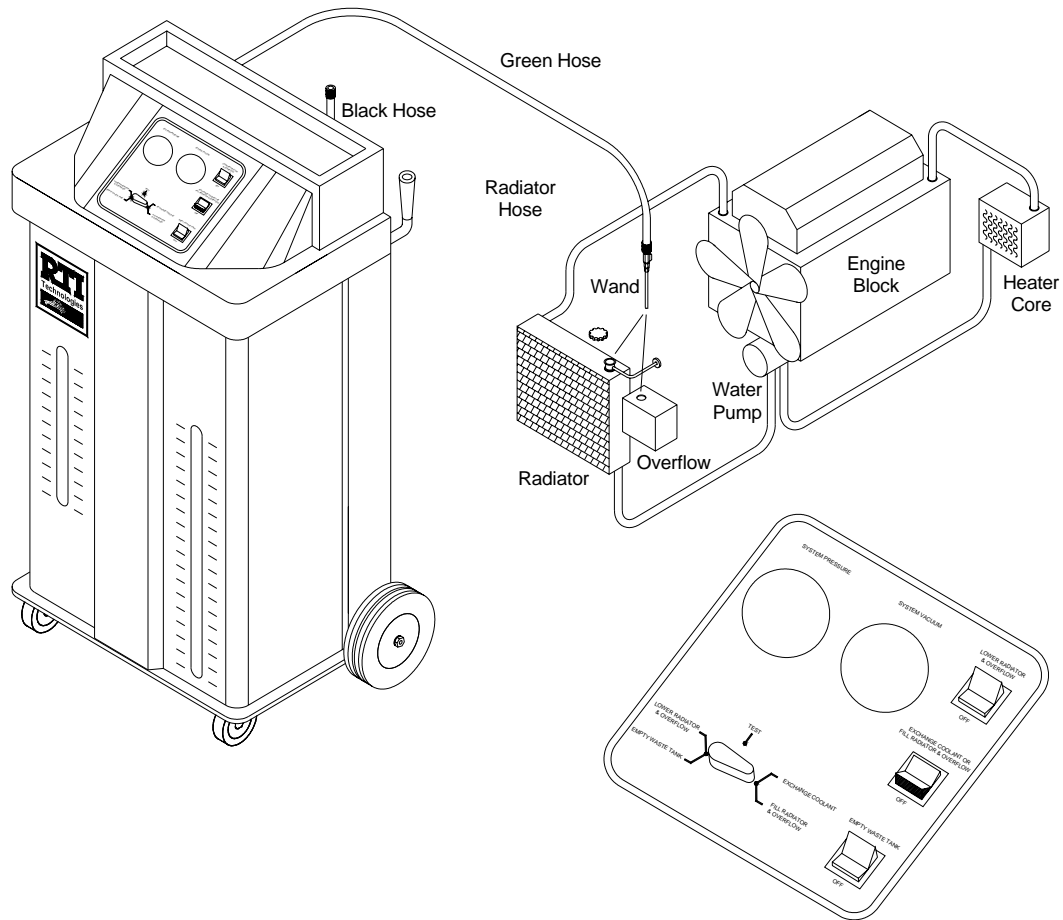

8. Remove the Step Adapters from the radiator hose and the Adapter Hose.
9. Remove the Adapter Hose and reattach the radiator hose.
10. Remove the overflow container cap.
11. Install the Wand on the green hose. Close the valve.
12. Turn control valve to FILL RADIATOR & OVERFLOW.
13. Press the top of EXCHANGE COOLANT OR FILL RADIATOR & OVERFLOW selector switch to turn on the pump.
14. Open the valve on the Wand to fill the radiator and overflow container to the recommended levels.
15. Replace the radiator cap and overflow container cap.
16. Press the bottom of the EXCHANGE COOLANT OR FILL RADIATOR & OVERFLOW selector switch and disconnect power cord.

# CHANGING COOLANT TYPE

The MCX-2S has a means for easily using different types of coolants. A special feature is the clearing process which purges coolant from the hoses and pumps prior to changing the new coolant tank. The MCX-2S must be connected to a battery during this procedure.

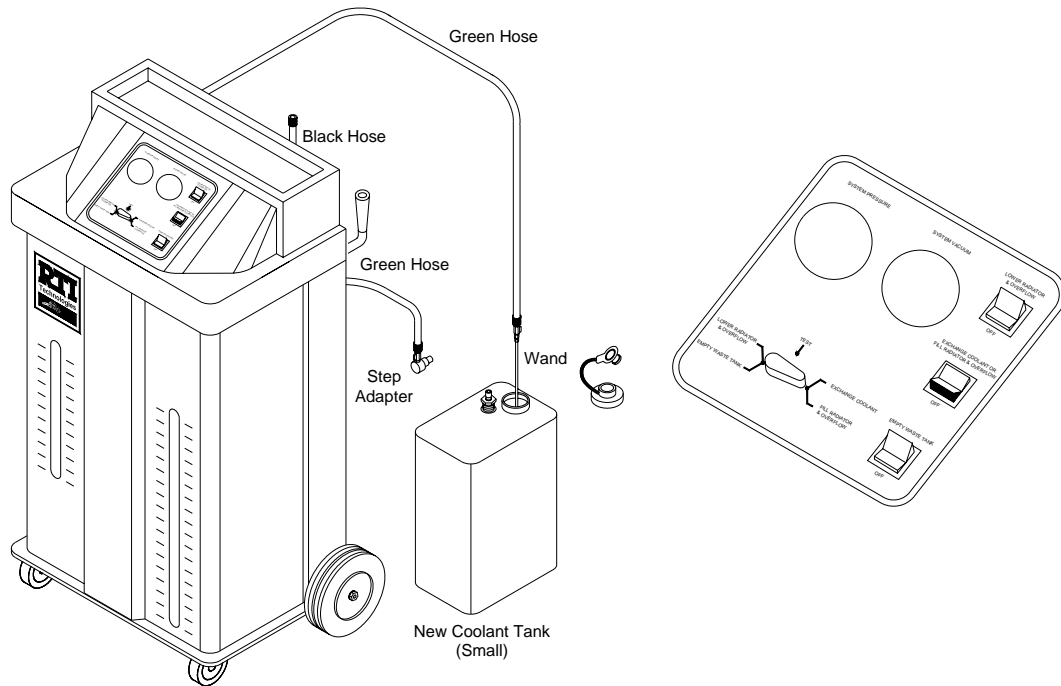

1. Slide the New Coolant Tank to the rear and sit it on the floor.
2. Disconnect the green hose from the tank and install a Step Adapter on the end. Close the valve on the Step Adapter.
3. Close the valve and install the Wand on the long green hose.
4. Turn control valve to FILL RADIATOR & OVERFLOW.
5. Press the top of the EXCHANGE COOLANT OR FILL RADIATOR & OVERFLOW selector switch to start the pump.
6. Insert the end of the Wand in the fill port of the New Coolant Tank. Open the valve on the Wand and then open the valve on the Step Adapter. All coolant in the hoses and pump will be emptied into the New Coolant Tank.
7. Close the valve on the Wand and Step Adapter. Press the bottom of the EXCHANGE COOLANT OR FILL RADIATOR & OVERFLOW selector switch to turn off the pump.
8. Remove the Step Adapter from the green hose and connect the hose to a New Coolant Tank with a different type of coolant.

**Continued on next page . . .**

# CHANGING COOLANT TYPE

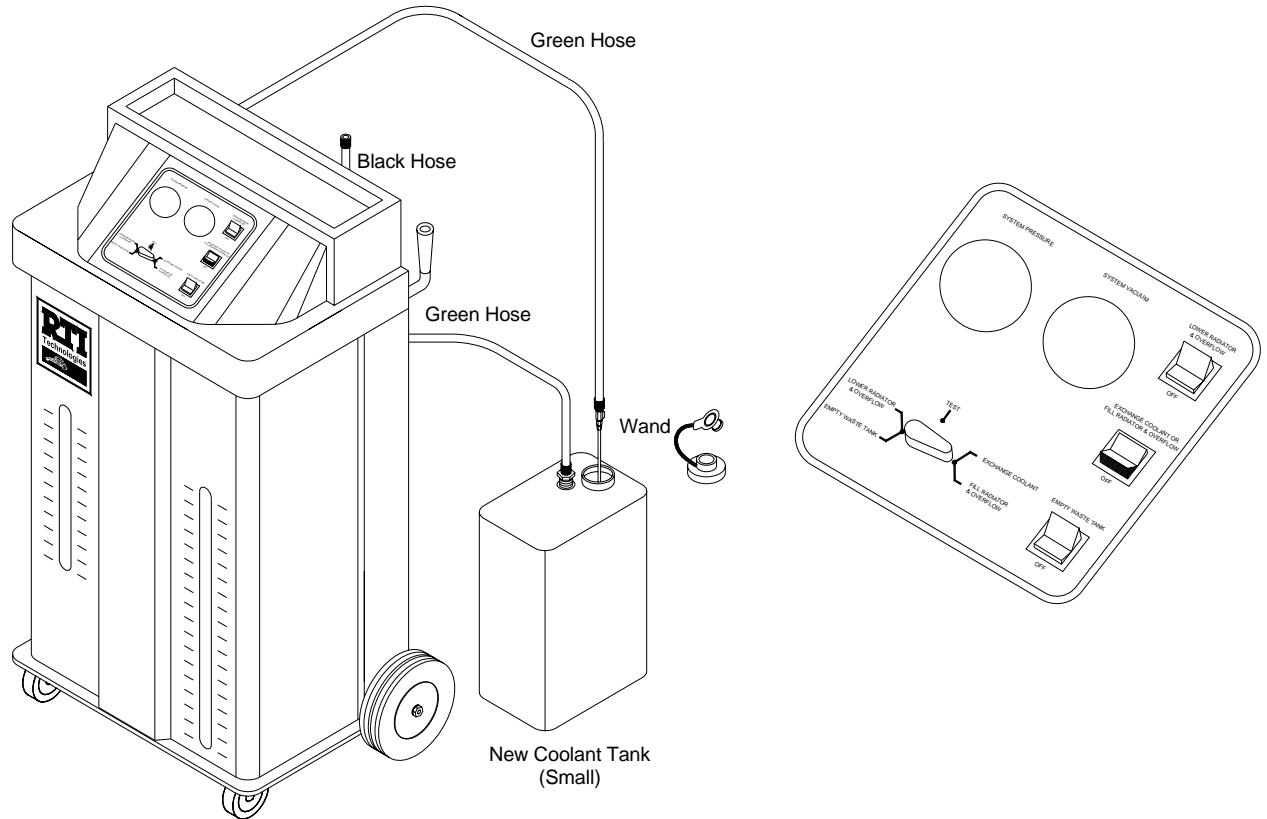

9. Press the top of the EXCHANGE COOLANT OR FILL RADIATOR & OVERFLOW selector switch to start the pump.
10. Insert the end of the Wand in the fill port of the New Coolant Tank. Open the valve on the Wand.
11. The pump will prime and hoses will fill with the new coolant.
12. Close the valve on the Wand when new coolant starts flowing.
13. Press the bottom of the EXCHANGE COOLANT OR FILL RADIATOR & OVERFLOW selector switch to turn off the pump.
14. Place the cap on the New Coolant Tank and slide it into the MCX-2S.

# EMPTYING THE WASTE TANK

The MCX-2S will pump the waste coolant directly from the Waste Tank into another waste collection tank. A 12 volt battery will be required to power the MCX-2S.

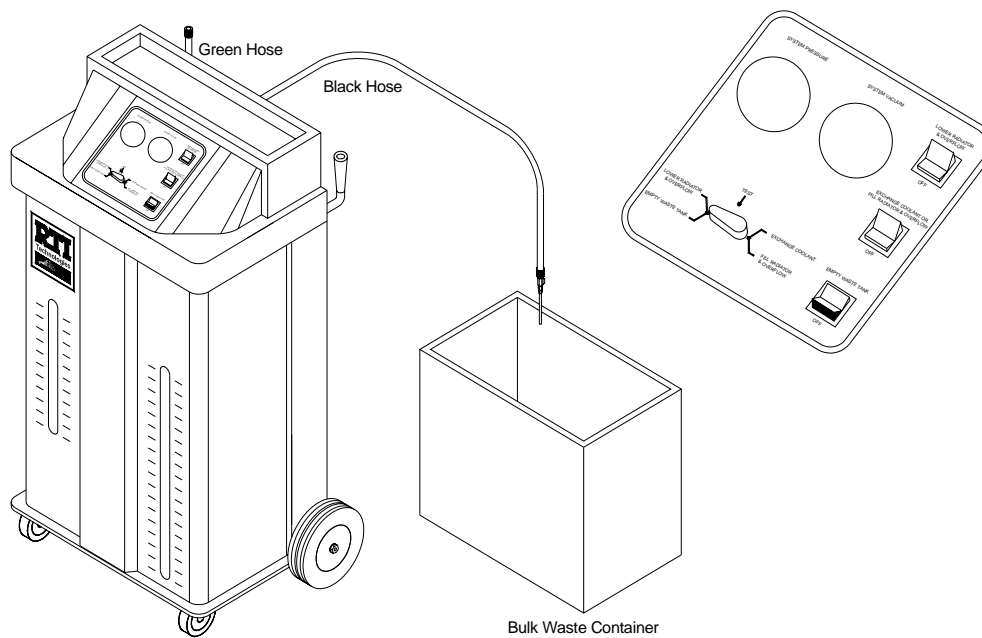





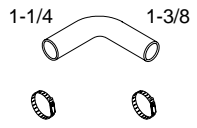

1. Install the Wand on the black hose.
2. Turn the control valve to EMPTY WASTE TANK.
3. Press the top of the EMPTY WASTE TANK selector switch to start the pump.
4. Hold the Wand over the Bulk Waste Container and open the valve.
5. Waste coolant will be pumped directly from the MCX-2S Waste Tank into the Bulk Waste Container.
6. The Waste Tank will empty and the pump will shut off. A float switch in the Waste Tank controls this function.
7. Close the valve on the Wand when done.
8. Press the bottom of the EMPTY WASTE TANK selector switch.

Note: The Waste Tank has a float switch which detects when the tank is empty and shuts off the waste pump.

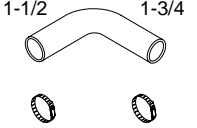
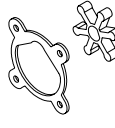
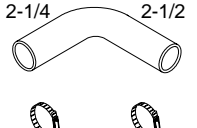
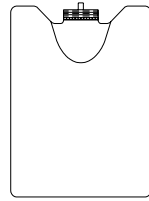
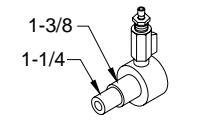
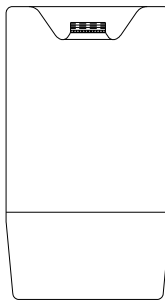
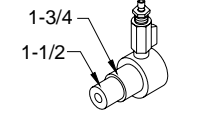
# REPLACEMENT PARTS - POWS Numbers

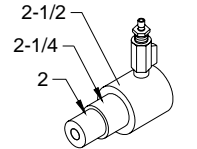
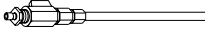
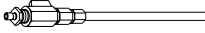
Visit our web-site at [www.rtitech.com](http://www.rtitech.com)

|  |   |              |   |   |              |
|--|---|--------------|---|---|--------------|
|  <p>1-1/4      1-3/8</p>        | <p>Small Adapter Hose<br/>(Includes 2 Clamps)</p>       | <p>62105</p> |   | <p>3-Bolt Style<br/>Impeller &amp; Gasket<br/>(For Waste Pump M2)</p> | <p>62116</p> |
|  <p>1-1/2      1-3/4</p>        | <p>Large Adapter Hose<br/>(Includes 2 Clamps)</p>       | <p>62108</p> |   | <p>4-Bolt Style<br/>Impeller &amp; Gasket<br/>(For Waste Pump M2)</p> | <p>62297</p> |
|  <p>2-1/4      2-1/2</p>        | <p>Extra Large Adapter Hose<br/>(Includes 2 Clamps)</p> | <p>62109</p> |   | <p>New Coolant Tank</p>   | <p>62117</p> |
|  <p>1-3/8<br/>1-1/4</p>         | <p>Small Step Adapter</p>                               | <p>62106</p> |  | <p>Waste Tank</p>   | <p>62118</p> |
|  <p>1-3/4<br/>1-1/2</p>        | <p>Large Step Adapter</p>                               | <p>62110</p> |  | <p>Level Magnet<br/>(Package of 6)</p>                                | <p>62119</p> |
|  <p>2-1/2<br/>2-1/4<br/>2</p> | <p>Extra Large Step Adapter</p>                         | <p>62114</p> |  | <p>Tank Label<br/>Conventional Green Gold</p>                         | <p>62120</p> |
|                               | <p>Wand</p>   | <p>62107</p> |  | <p>Tank Label<br/>Extended Life - Orange</p>                          | <p>62121</p> |
|                               | <p>Fuse 15 AMP</p>                                      | <p>62115</p> |   |   |              |

**Technical Support: 800-468-2321**  
**Mon. - Fri. 8AM - 5PM (Eastern Time)**  
**Sat. - Sun. 8AM - 12PM (Eastern Time)**

# WASTE PUMP IMPELLER REPLACEMENT

The waste pump impeller may require periodic replacement. The concentration of impurities in recovered waste coolant affects the life of the pump impeller. Changing the impeller is quick and easy as follows:

1. The Waste Pump is accessible through a hole in the Hose Holder on the rear of the MCX-2S.
2. Remove screws.
3. Remove cover plate, gasket and worn impeller.
4. Coat new impeller with Vaseline<sup>®</sup> petroleum jelly.
5. Align flats and press impeller onto shaft.
6. Attach new gasket and cover plate.

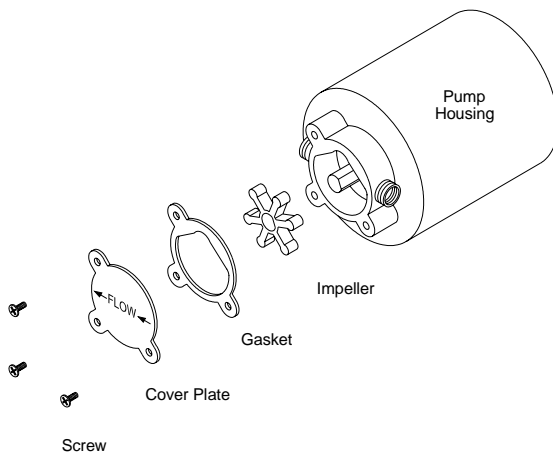

3-Bolt Style

Impeller & Gasket

Part Number: 62116

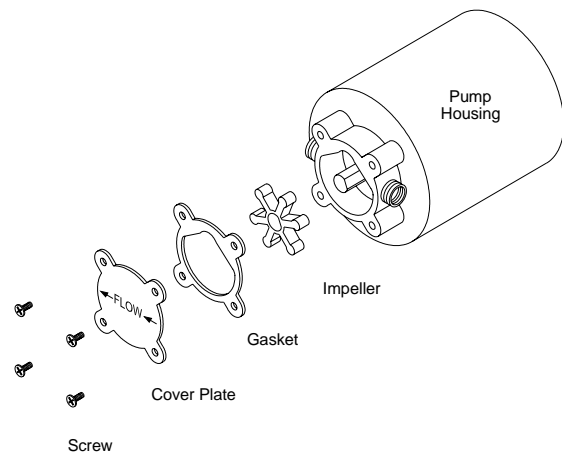

4-Bolt Style

Impeller & Gasket

Part Number: 62297

# FLOW & WIRING DIAGRAM

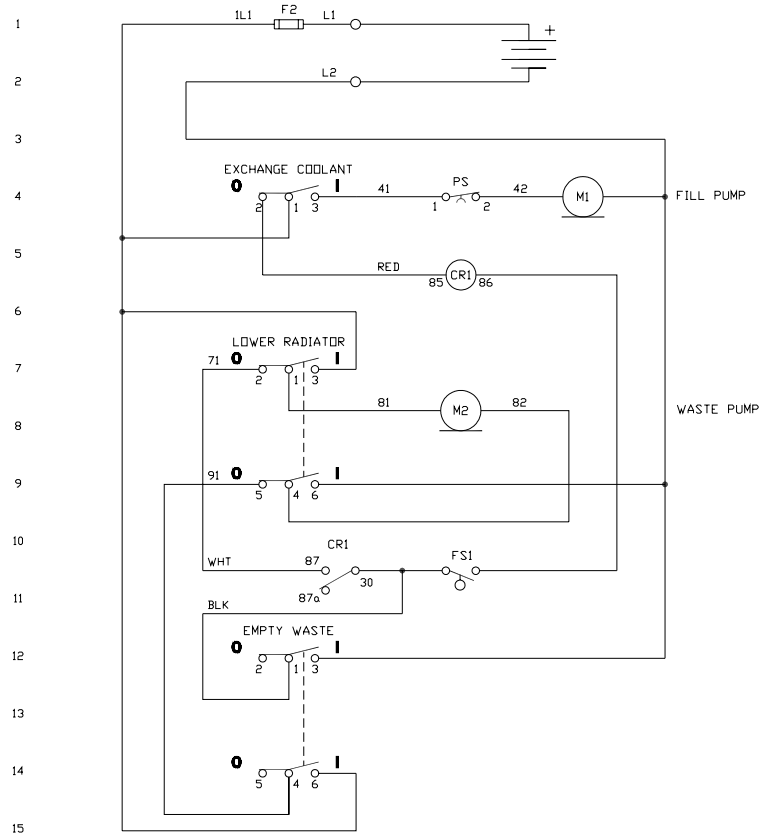
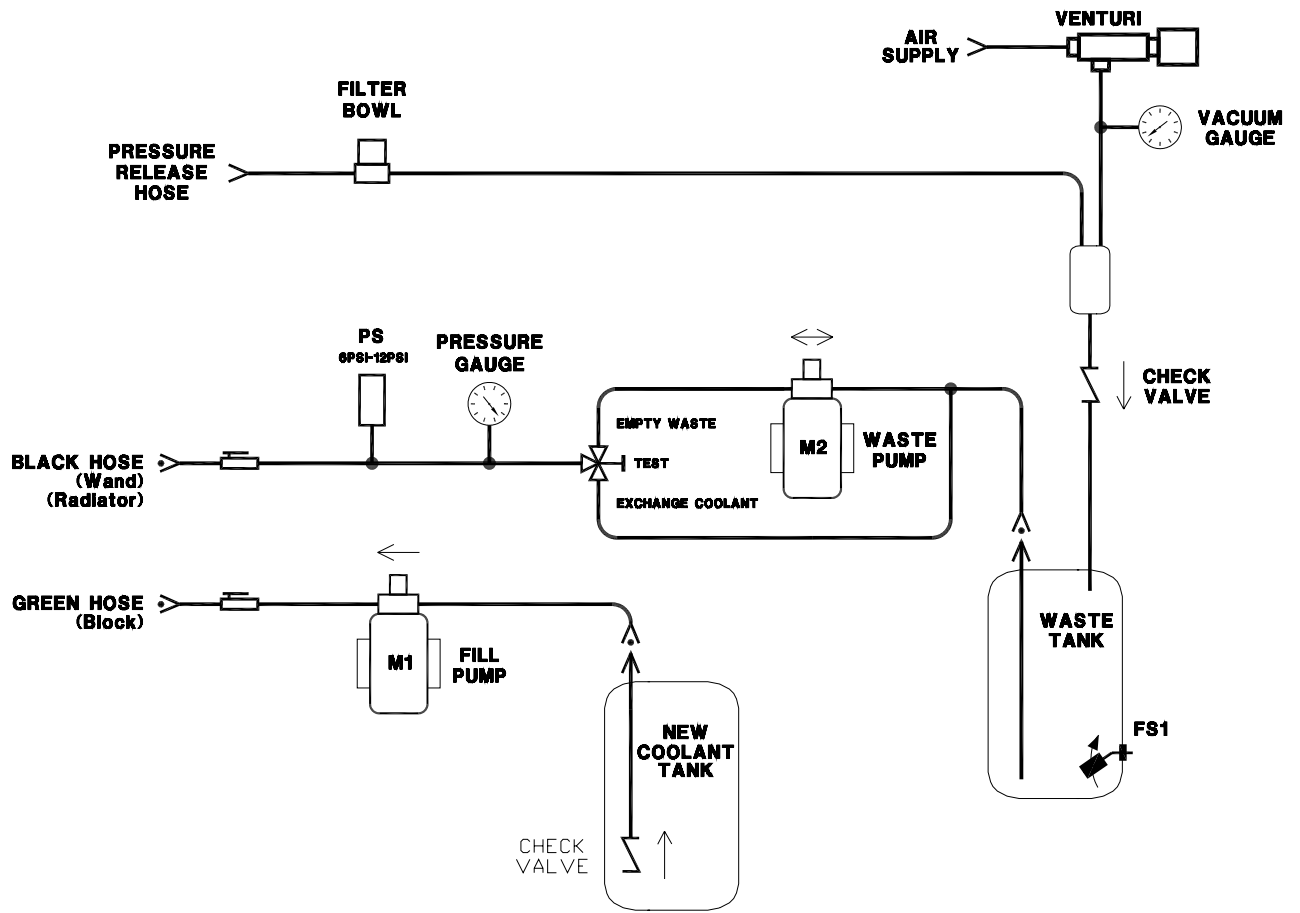

DATE: 09-22-04