

OPERATION MANUAL

MCX-2F

Multiple Coolant Exchanger
(With Flush & Flow Indicator)

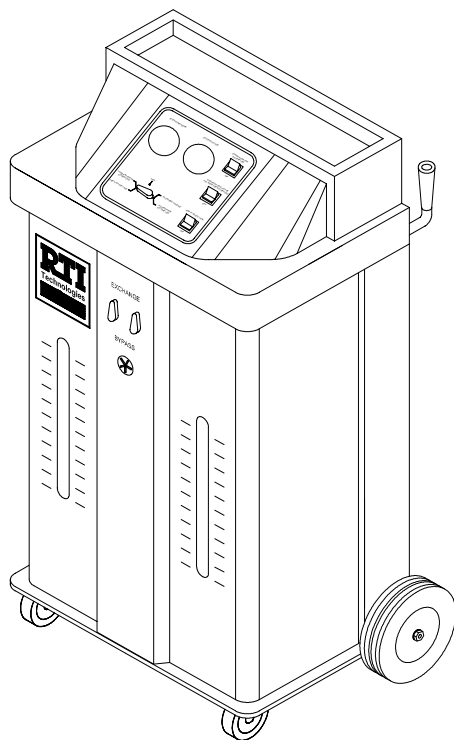

RTI Technologies, Inc.

4075 East Market Street

York, Pennsylvania USA

800-468-2321

www.rtitech.com

Manual Number 035-80833-00

TABLE OF CONTENTS

Component Description	2
Safety Precautions	3
Set-up	4
Connection to Power	5
Relieving Radiator Pressure	6
Lowering Coolant Level	7
Connecting to the Coolant System	8
Special Hookups	9
Engine Flush	10
Coolant Replacement	11
Test Coolant System for Leaks	12
Completing the Job	13
Changing Coolant Type	15
Emptying the Waste Tank	17
Replacement Parts	18
Waste Pump Impeller Replacement	19
Flow & Wiring Diagram	20

COMPONENT DESCRIPTION

Unpack all components and verify quantities per this illustration.

Contact RTI if any items are missing or damaged.

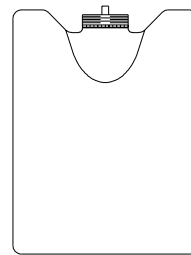
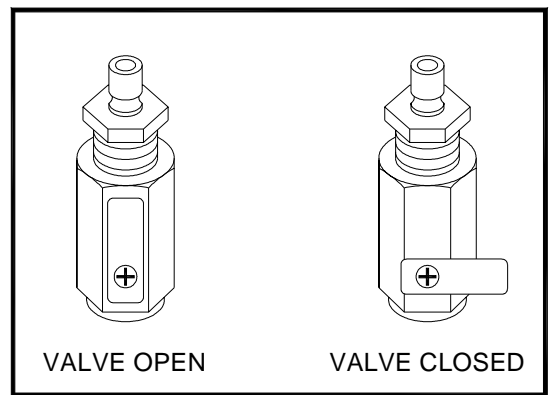
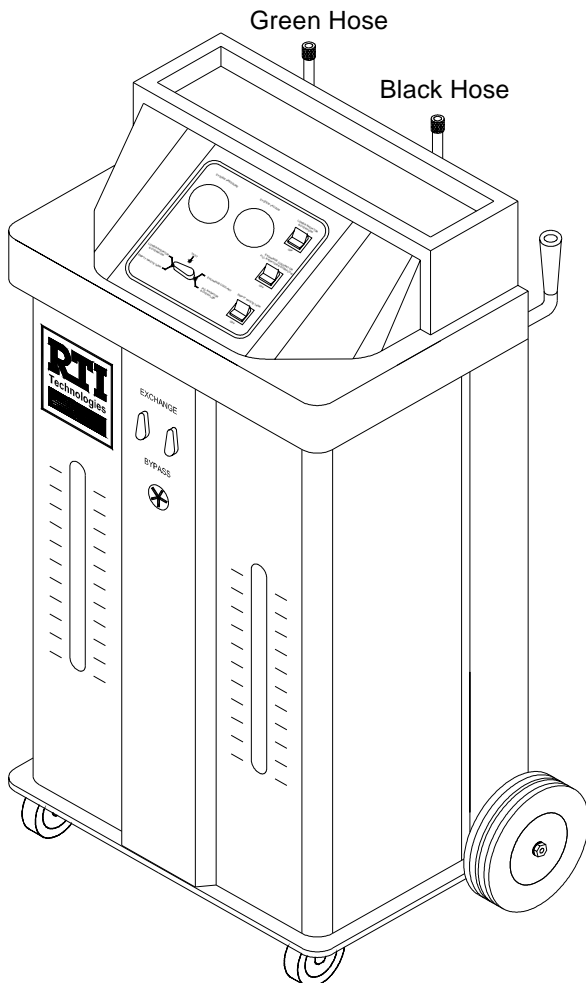
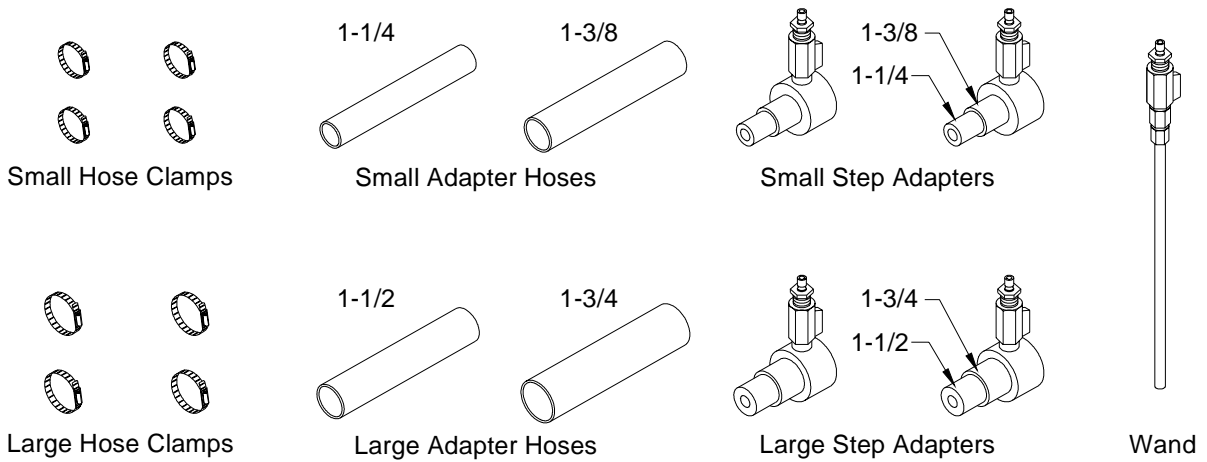

New Coolant Tank
(Qty=2)

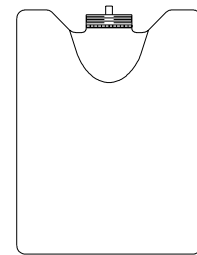

Waste Tank

SAFETY PRECAUTIONS

WARNING: FAILURE TO FOLLOW THESE PRECAUTIONS CAN RESULT IN SERIOUS INJURY OR DEATH.

- Read and understand the Operation Manual completely before operating this unit.
- Always wear proper eye and skin protection when operating and maintaining this equipment.
- Take precautions to keep clothing, hair, hands, hoses, etc. away from all moving parts on the vehicle.
- Automotive cooling systems can be under pressure and extremely hot. Allow the cooling system to cool down and use extreme caution when removing caps and hoses.
- Coolants are poisonous to people and animals and are also corrosive. Clean up any spills immediately.

CAUTION: FAILURE TO FOLLOW THE PRECAUTIONS AS OUTLINED IN THE OPERATION MANUAL CAN RESULT IN DAMAGE TO THE ENGINE, VEHICLE OR EQUIPMENT WHICH WILL NOT BE SUPPORTED OR COVERED UNDER WARRANTY.

- Do not allow waste coolant tank to overflow. Immediately clean up any coolant spills. Damage to the vehicle and equipment can result from the corrosiveness of coolant.
- Continuous monitoring of the coolant replacement process is required.

SET UP

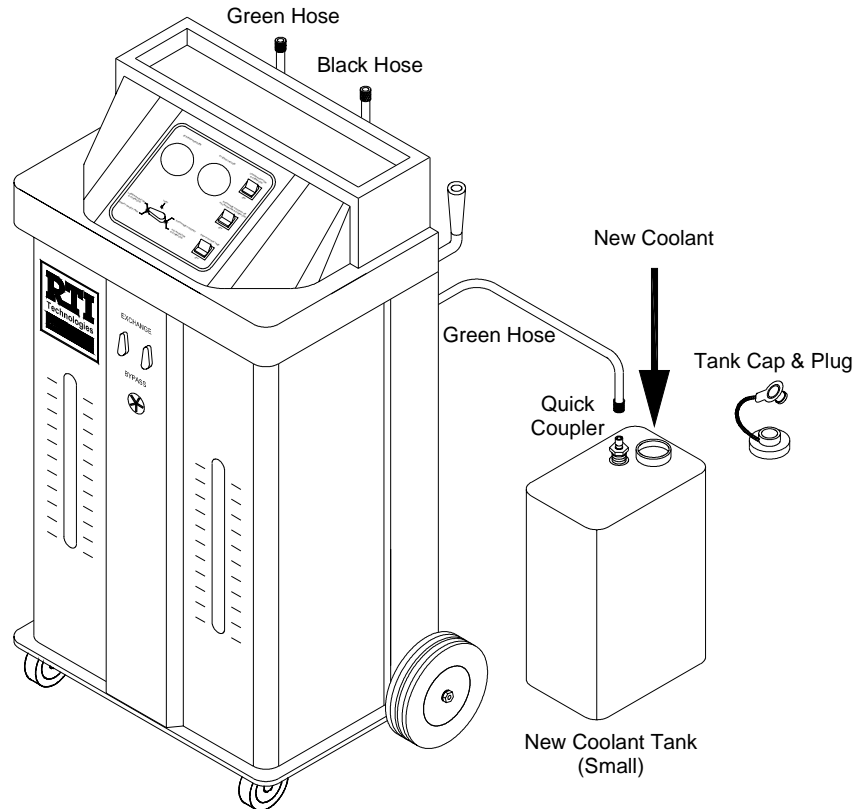

The MCX-2F has two tanks (plus an extra New Coolant Tank) which are installed and connected from the rear. Quick connect couplers are mounted on the hoses which connect these tanks to the MCX-2F. A green hose connects to the New Coolant Tank (right side) and a black hose connects to the Waste Tank (left side). The small diameter black drain hose must be inserted into the hole in the cap of the Waste Tank.

1. Slide the New Coolant Tank to the rear and sit it on the floor.
2. Remove the tank cap and fill the tank with new coolant and water in the proportions specified by the coolant supplier. The tank can be disconnected and moved to a bulk coolant storage area for filling if desired. A plug is provided on the cap to prevent spillage during transport.
3. Replace the tank cap and position the tank in the MCX-2F. Make sure the green hose is securely connected. Slide the tank to the front so the liquid level can be seen through the front panel slot.
4. **Make sure the plugs are removed from the caps on the Waste Tank and the New Coolant Tank. This is required for venting the tanks during operation. The small diameter black drain hose must be inserted into the hole in the cap of the Waste Tank.**
5. Fasten the clips on the tank strap to secure the tanks in the MCX-2F.

CONNECTION TO POWER

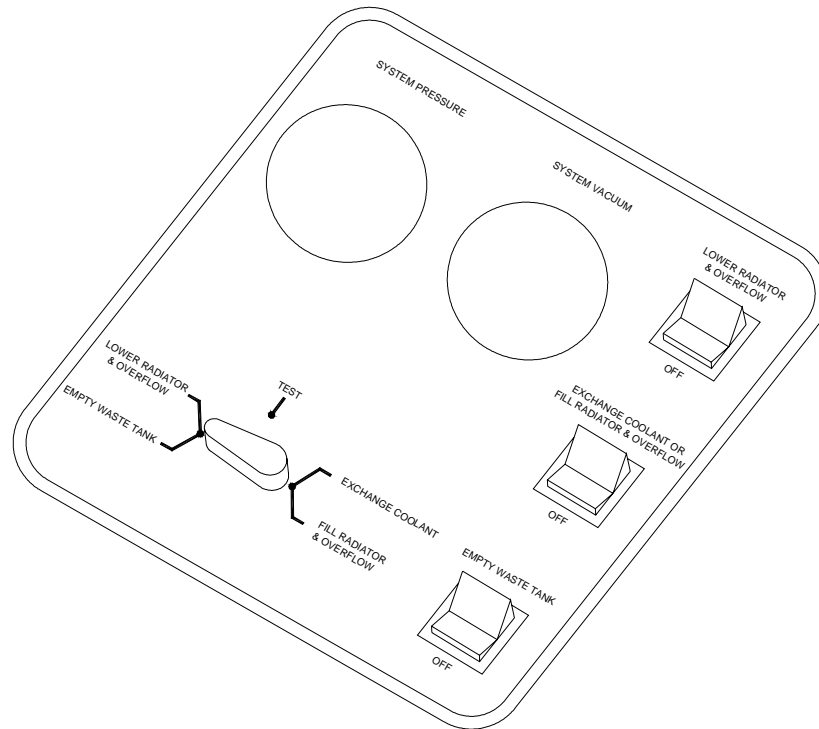

The MCX-2F control panel is illustrated above. Note that the bottom of all three selector switches has been pressed which turns all functions off. **Make sure all switches are off before connecting the battery cable clips to the battery of the vehicle.**

WARNING: Handle battery connection cable with extreme caution. Batteries generate explosive gases during normal operation. Working in the vicinity of a lead-acid or other automotive battery is dangerous. Wear eye protection. Never smoke or allow a spark or flame in the vicinity of the battery. Do not connect the black power clip to the negative post of the battery to avoid a spark.

1. Verify that all switches are in the off position.
2. Connect the red power clip to the "+" (positive) post of the vehicle battery. The battery must be 12 volt.
3. Connect black power clip to an engine ground (not the negative post of the battery).

RELIEVING RADIATOR PRESSURE

WARNING: Coolant in the vehicle cooling system may be extremely hot and under great pressure. Wear safety glasses and use protective clothing and gloves. Use extreme caution when removing radiator cap and hoses.

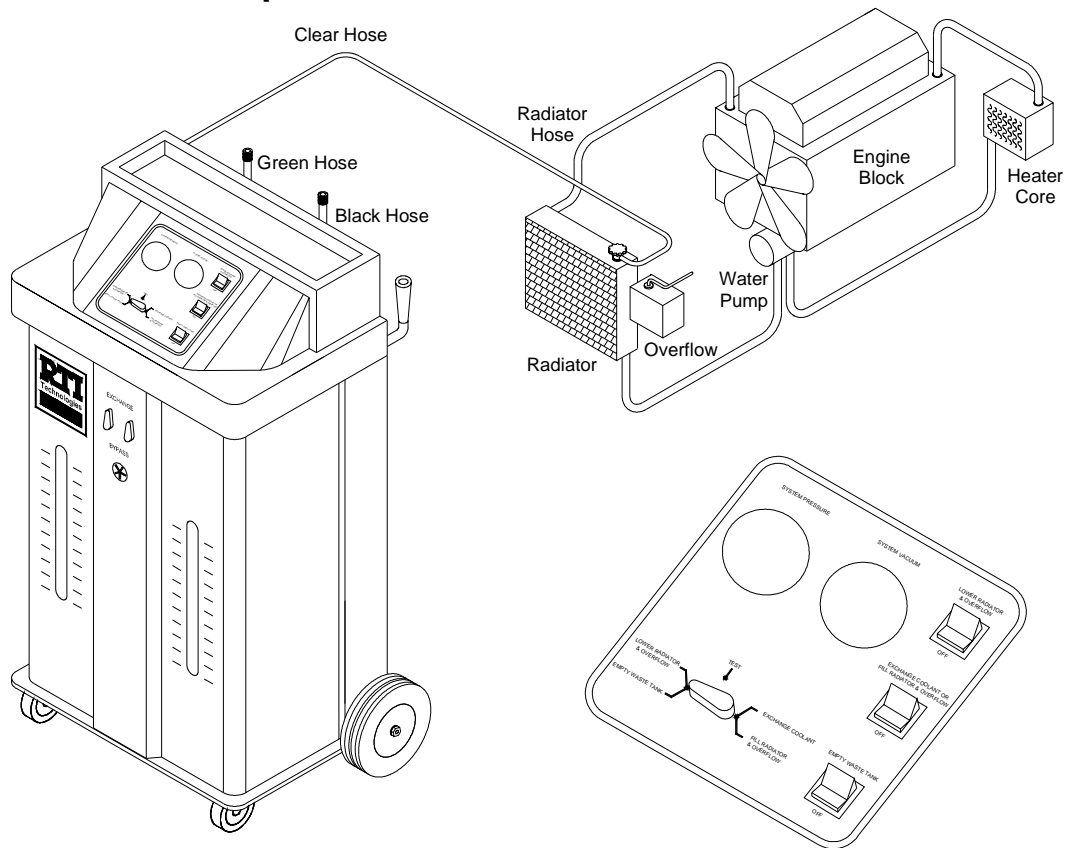

NOTE: The MCX-2F does not need to be connected to power for the following.

The MCX-2F will relieve the pressure in a hot-car radiator by drawing a vacuum on the overflow port on the radiator cap.

Shop air (55 to 100 PSI), connected to the rear port of the MCX-2F causes a vacuum to be pulled on the small diameter clear hose, also connected to the rear. This clear hose is connected to the overflow port on the radiator cap as shown above.

The system Vacuum Gauge on the MCX-2F control panel indicates the vacuum level which will increase until the radiator cap opens and relieves the pressure. As the pressure releases a small amount of coolant will be seen flowing in the clear hose. When the pressure has been relieved, the radiator cap will again close and the vacuum level will increase and become steady on the gauge.

The radiator cap can now be slowly and carefully removed.

CONNECTING TO THE COOLANT SYSTEM

The MCX-2F can be connected to the cooling system in either of the configurations shown below. The choice is dependent on the ease of accessibility to the hose connections.

1. Turn both valves on the front of the MCX-2F to EXCHANGE.
2. Disconnect the radiator hose from either the engine or the radiator.
3. Select an Adapter Hose with the same inner diameter as the radiator hose and connect at the point the radiator hose was disconnected using a clamp.
4. Install Step Adapters in the Adapter Hose and the radiator hose using clamps. Make sure the outside diameter of the Step Adapters is the same as the inner diameter of the radiator hose.
5. Connect the Green and Black hoses from the MCX-2F to the two Step Adapters as shown in the illustrations. **See next page for special hookups.**
6. Open the valves on the two Step Adapters.

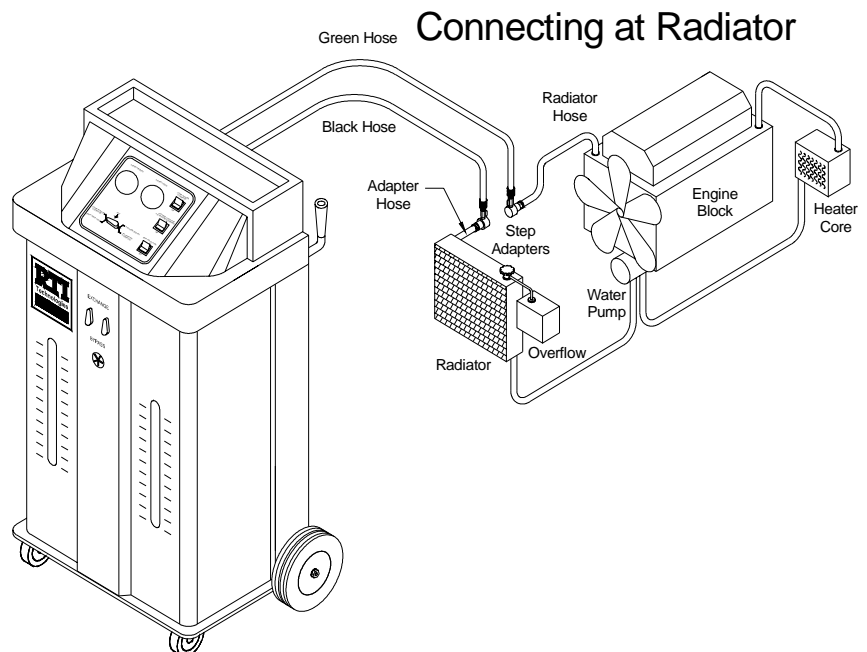
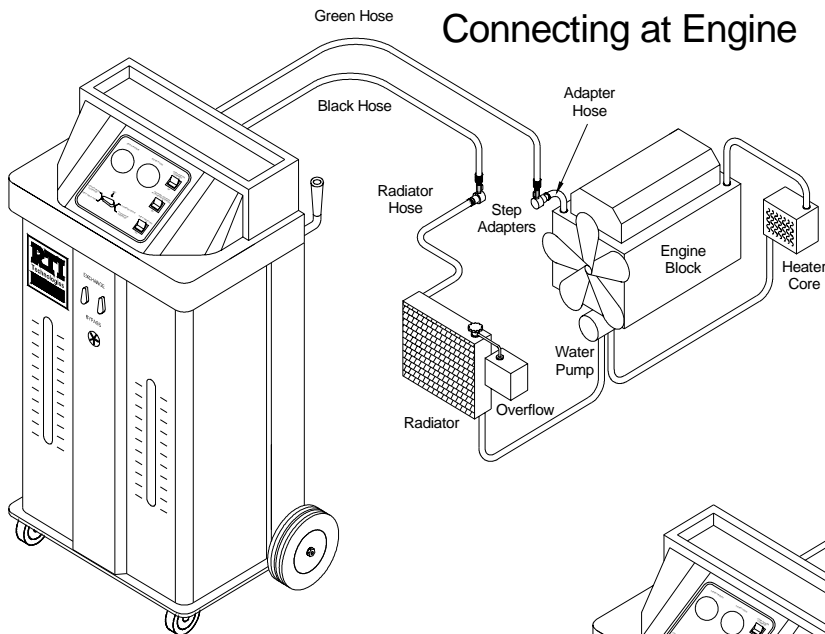

SPECIAL HOOKUPS

Special Hookup 1) It may be necessary to reverse the hoses during the coolant replacement procedure on the next page for systems with a reverse-connected thermostat. See note after Step 6 on next page for the symptoms of this situation.

Special Hookup 2) Some cooling systems do not have a cap on the radiator. Instead, there is a single cap on the overflow tank as shown in the illustration below.

The hoses to and from the overflow tank must be pinched using hose pinching pliers during the coolant replacement procedure on the next page.

Failure to pinch these hoses will cause fluid to be forced out of the vented cap on the overflow tank during the coolant replacement procedure.

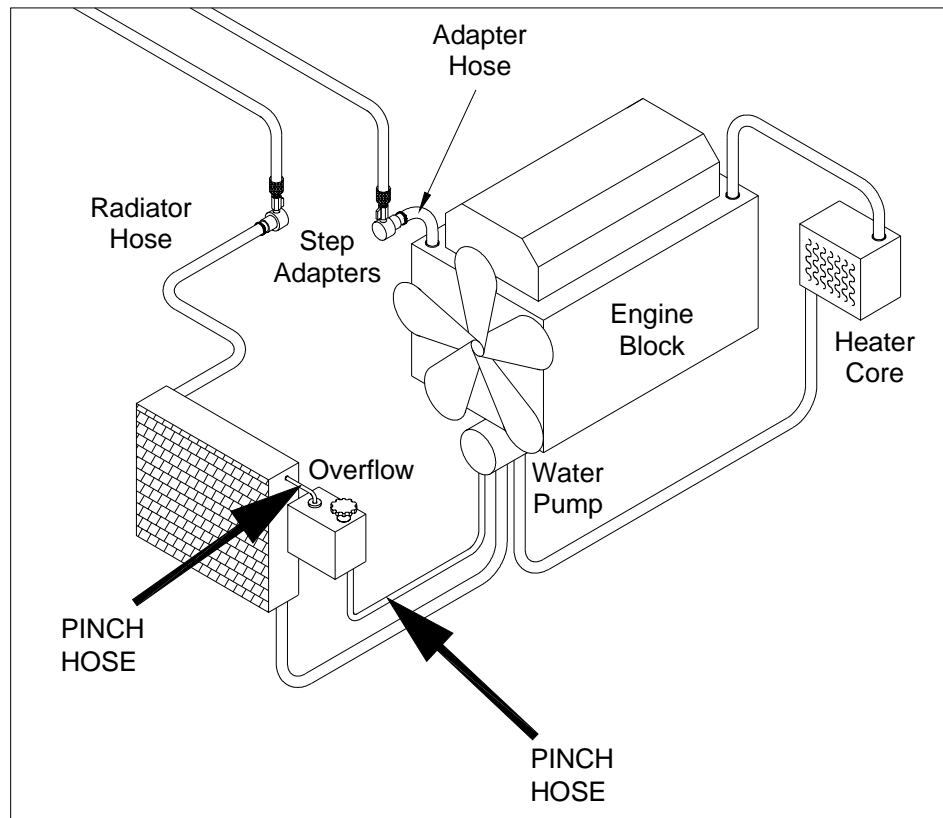

ENGINE FLUSH

The engine can be flushed with a chemical additive with the MCX-2F connected as described in preceding pages. Two valves located on the front panel each have two positions - EXCHANGE and BYPASS.

When the valves are both turned to the BYPASS position the coolant in the vehicle bypasses the MCX-2F. It flows through the green and black hoses which are connected together inside the MCX-2F by the two valves being in the BYPASS position.

Flush (or leak sealant) additives can be added to the vehicle cooling system through the radiator fill port. The engine can then be started to circulate the additives throughout the cooling system.

Connecting the MCX-2F to the cooling system prior to adding additives and running the engine eliminates the need to make connections involving hot coolant.

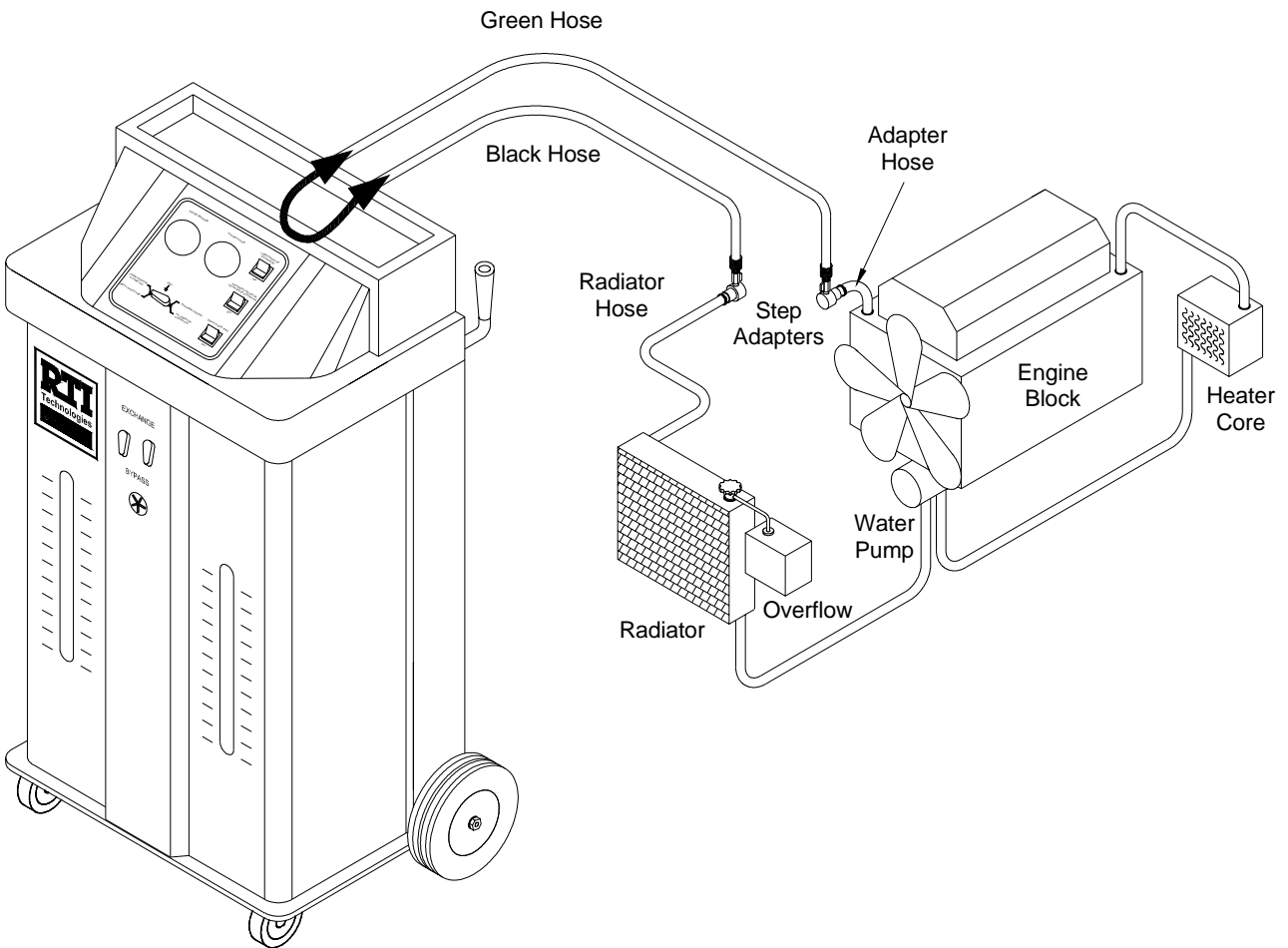

Coolant bypasses MCX-2F when both valves are turned to BYPASS

COOLANT REPLACEMENT

Once the MCX-2F is connected as described on the preceding pages it is ready to replace the old coolant with new coolant.

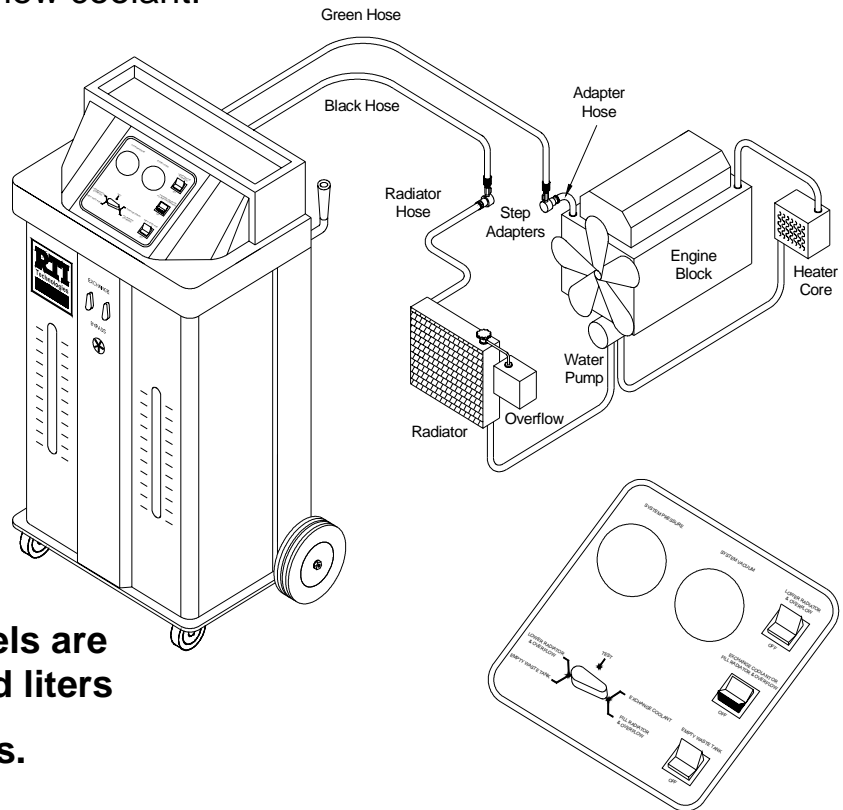

Scales for the tank levels are graduated in quarts and liters

1 Gallon = 4 Quarts.

1. Determine the capacity and type of coolant for the vehicle cooling system. Refer to the vehicle Owner's Manual.
2. Make sure the New Coolant Tank (left slot on front) is filled with the correct coolant and at a level higher than the amount required to fill the coolant system to full capacity.
3. Check the Waste Tank (right slot on front) to make sure the level is low enough to accept the full capacity of coolant in the vehicle cooling system.
4. Turn both valves on front of MCX-2F to EXCHANGE.
5. Turn control valve to EXCHANGE COOLANT.
6. Press the top of EXCHANGE COOLANT OR FILL RADIATOR & OVERFLOW selector switch to turn on the pump.
7. Watch the level of coolant as it lowers in the New Coolant Tank. Press the bottom of the EXCHANGE COOLANT OR FILL RADIATOR & OVERFLOW selector switch when it reaches the correct level. This will stop the transfer of coolant.

If the pump is running and the new coolant level does not go down:
Try reversing the connections of the green and black hoses.

TEST COOLANT SYSTEM FOR LEAKS

The MCX-2F can be used to check the coolant system for leaks. The coolant system is pressurized and the System Pressure Gauge on the MCX-2F is monitored for a drop in pressure which would indicate a system leak.

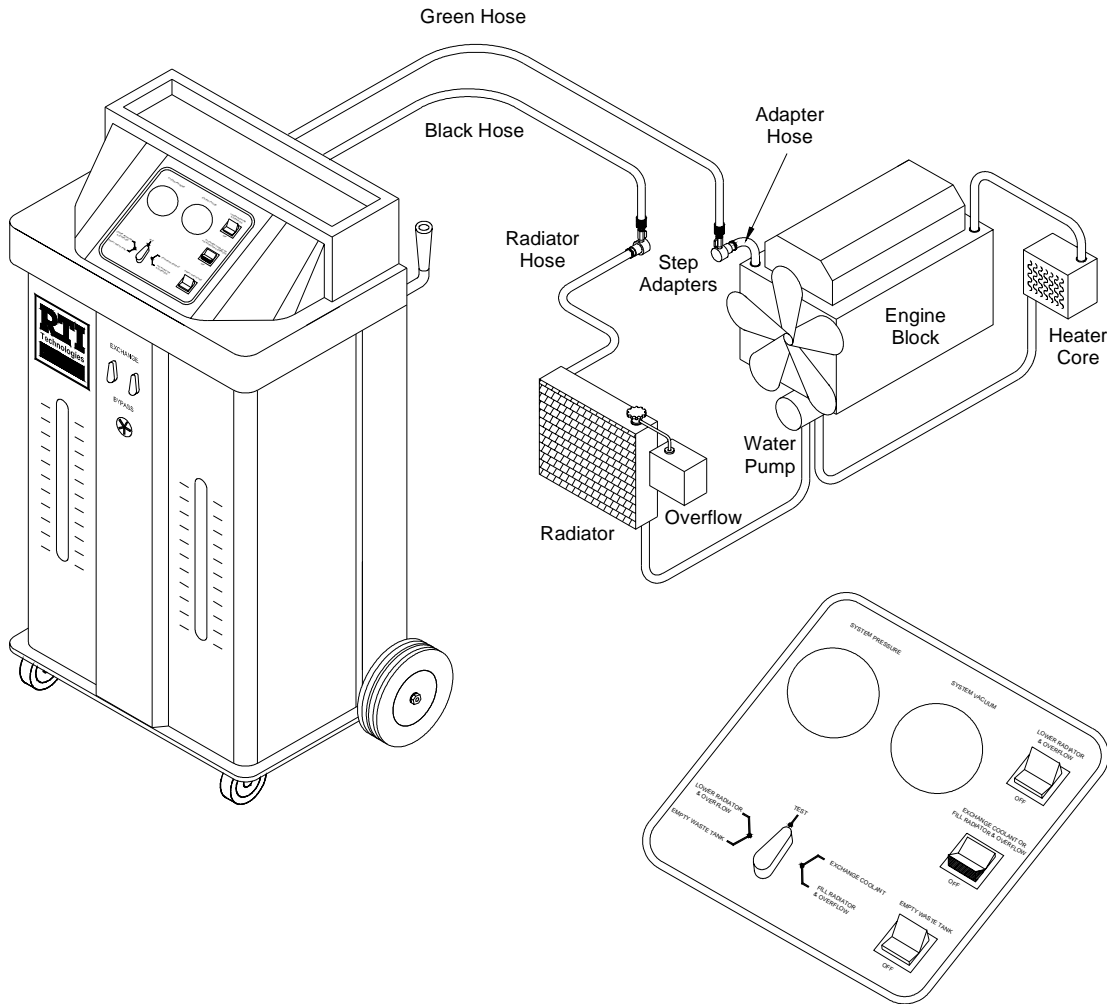

The MCX-2F should be connected as shown above.

1. Turn both valves on front of MCX-2F to EXCHANGE.
2. Turn control valve to TEST.
3. Press the top of EXCHANGE COOLANT OR FILL RADIATOR & OVERFLOW selector switch to turn on the pump.
4. Watch the System Pressure Gauge and press the bottom of the EXCHANGE COOLANT OR FILL RADIATOR & OVERFLOW selector switch when the pressure reaches 10 to 13 PSI.
5. The coolant system is now pressurized. Monitor the pressure for a constant reading. A coolant system leak is indicated if the pressure falls.

COMPLETING THE JOB

All used coolant in the vehicle cooling system has now been replaced with new coolant. The following steps will complete the job.

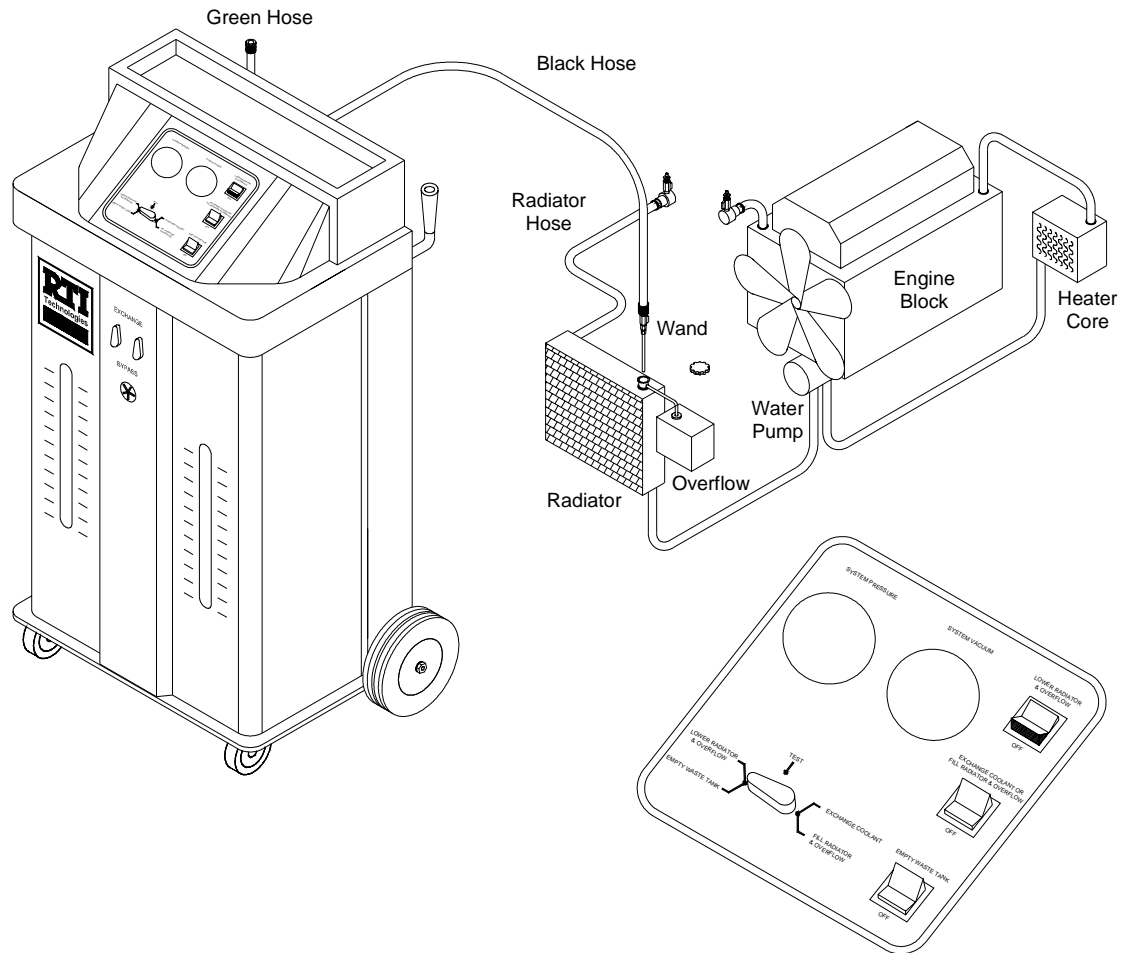

1. Turn both valves on front of MCX-2F to EXCHANGE.
2. Close the valves on the Step Adapters.
3. Disconnect the black and green hoses from the Step Adapters.
4. Install Wand on black hose. Close the valve.
5. Remove the cap from the radiator.
6. Turn control valve to LOWER RADIATOR & OVERFLOW.
7. Press top of LOWER RADIATOR & OVERFLOW selector switch to turn on pump.
8. Use the Wand to lower the level of coolant in the radiator to a level just below the upper hose where the Step Adapter is attached. Open valve on Wand as required.

Continued on next page . . .

COMPLETING THE JOB

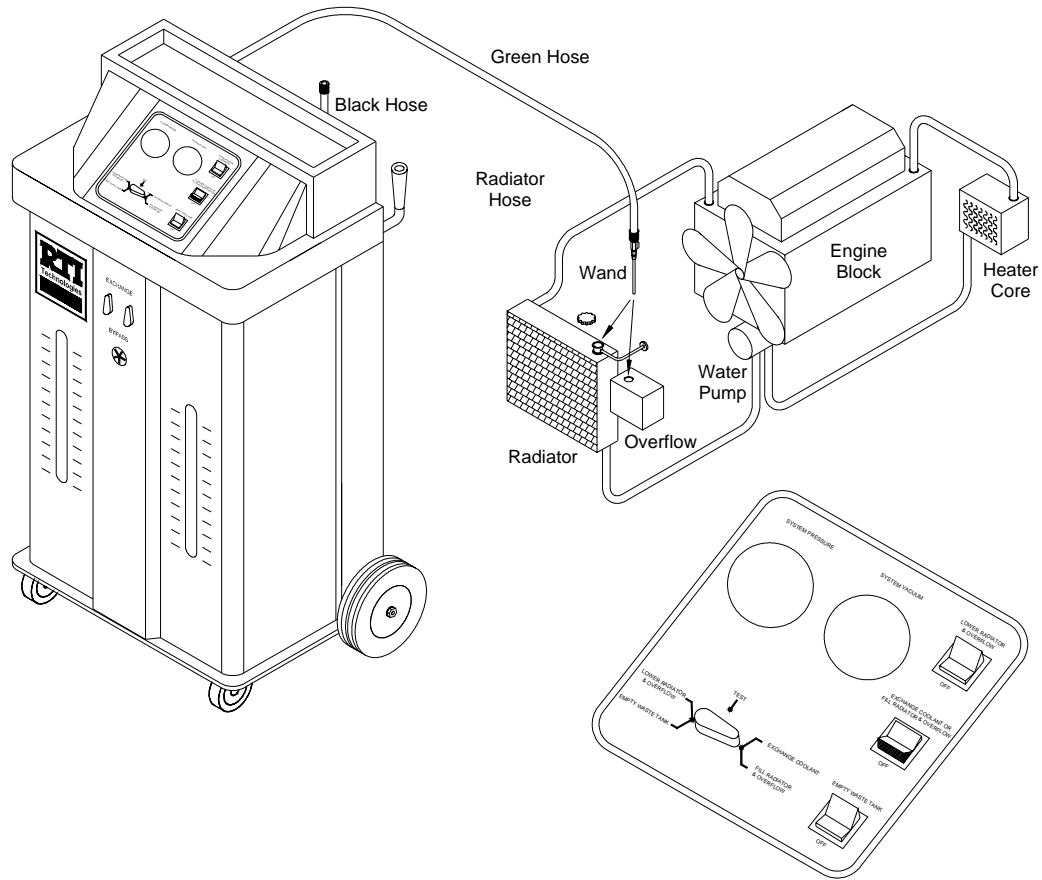

9. Remove the Step Adapters from the radiator hose and the Adapter Hose.
10. Remove the Adapter Hose and reattach the radiator hose.
11. Remove the overflow container cap.
12. Install the Wand on the green hose. Close the valve.
13. Turn control valve to FILL RADIATOR & OVERFLOW.
14. Press the top of EXCHANGE COOLANT OR FILL RADIATOR & OVERFLOW selector switch to turn on the pump.
15. Open the valve on the Wand to fill the radiator and overflow container to the recommended levels.
16. Replace the radiator cap and overflow container cap.
17. Press the bottom of the EXCHANGE COOLANT OR FILL RADIATOR & OVERFLOW selector switch and disconnect power cord.

CHANGING COOLANT TYPE

The MCX-2F has a means for easily using different types of coolants. A special feature is the clearing process which purges coolant from the hoses and pumps prior to changing the new coolant tank. The MCX-2F must be connected to a battery during this procedure.

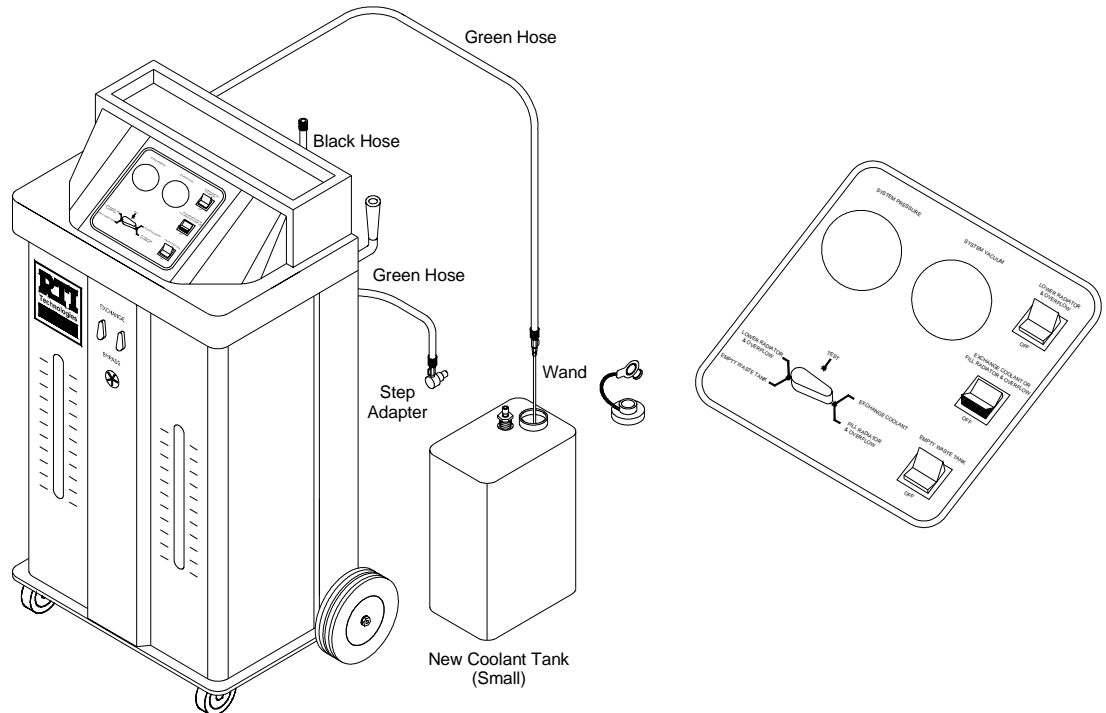

1. Slide the New Coolant Tank to the rear and sit it on the floor.
2. Disconnect the green hose from the tank and install a Step Adapter on the end. Close the valve on the Step Adapter.
3. Close the valve and install the Wand on the long green hose.
4. Turn both valves on the front of the MCX-2F to EXCHANGE.
5. Turn control valve to FILL RADIATOR & OVERFLOW.
6. Press the top of the EXCHANGE COOLANT OR FILL RADIATOR & OVERFLOW selector switch to start the pump.
7. Insert the end of the Wand in the fill port of the New Coolant Tank. Open the valve on the Wand and then open the valve on the Step Adapter. All coolant in the hoses and pump will be emptied into the New Coolant Tank.
8. Close the valve on the Wand and Step Adapter. Press the bottom of the EXCHANGE COOLANT OR FILL RADIATOR & OVERFLOW selector switch to turn off the pump.
9. Remove the Step Adapter from the green hose and connect the hose to a New Coolant Tank with a different type of coolant.

Continued on next page . . .

CHANGING COOLANT TYPE

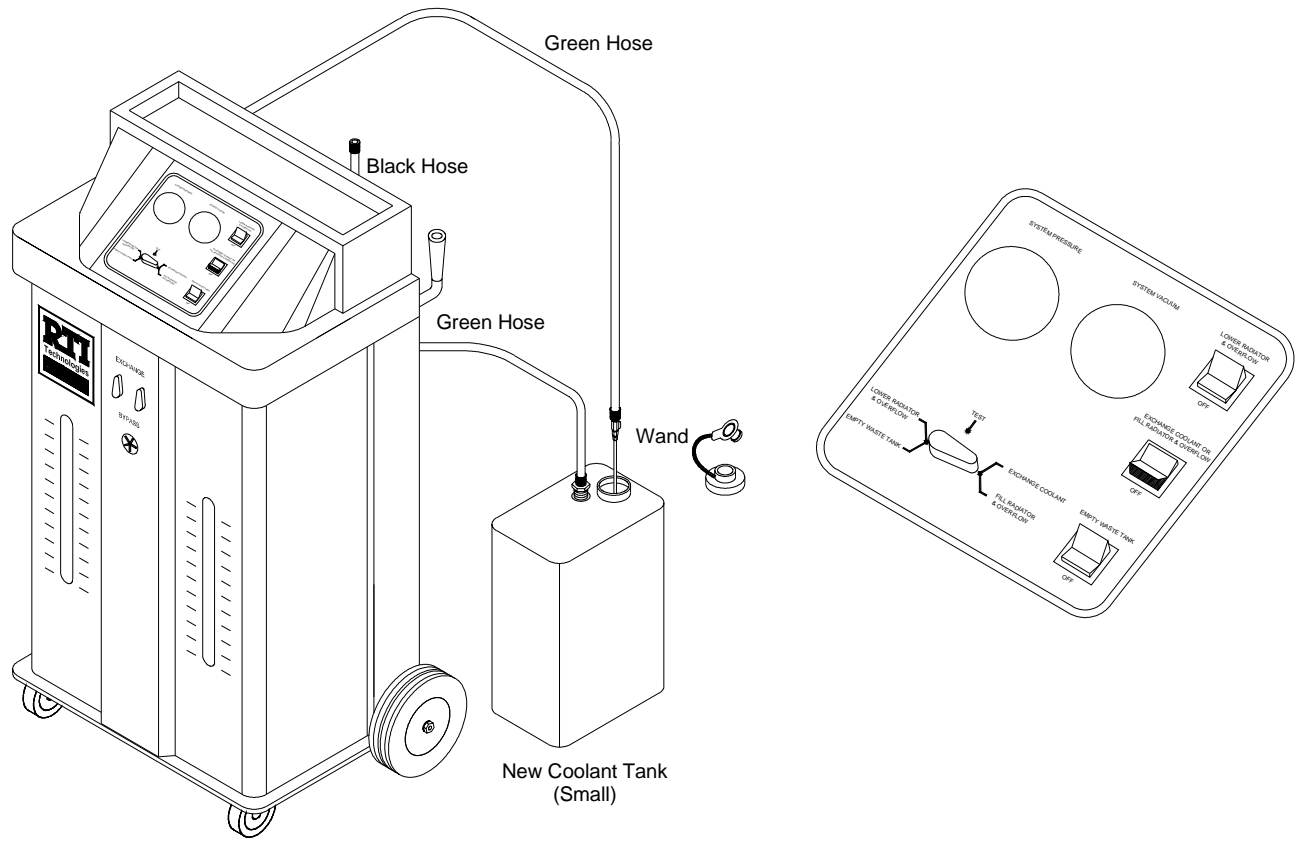

10. Press the top of the EXCHANGE COOLANT OR FILL RADIATOR & OVERFLOW selector switch to start the pump.
11. Insert the end of the Wand in the fill port of the New Coolant Tank. Open the valve on the Wand.
12. The pump will prime and hoses will fill with the new coolant.
13. Close the valve on the Wand when new coolant starts flowing.
14. Press the bottom of the EXCHANGE COOLANT OR FILL RADIATOR & OVERFLOW selector switch to turn off the pump.
15. Place the cap on the New Coolant Tank and slide it into the MCHX-2F.

EMPTYING THE WASTE TANK

The Waste Tank can be emptied two different ways.

- A. The Waste Tank can be removed from the MCX-2F and transported to the area where it is to be emptied. A quick connect coupler is installed on the black hose to make this disconnection quick and clean.
- B. The MCX-2F can be used to pump the waste coolant directly from the Waste Tank into another waste collection tank. A 12 volt battery will be required to power the MCX-2F.

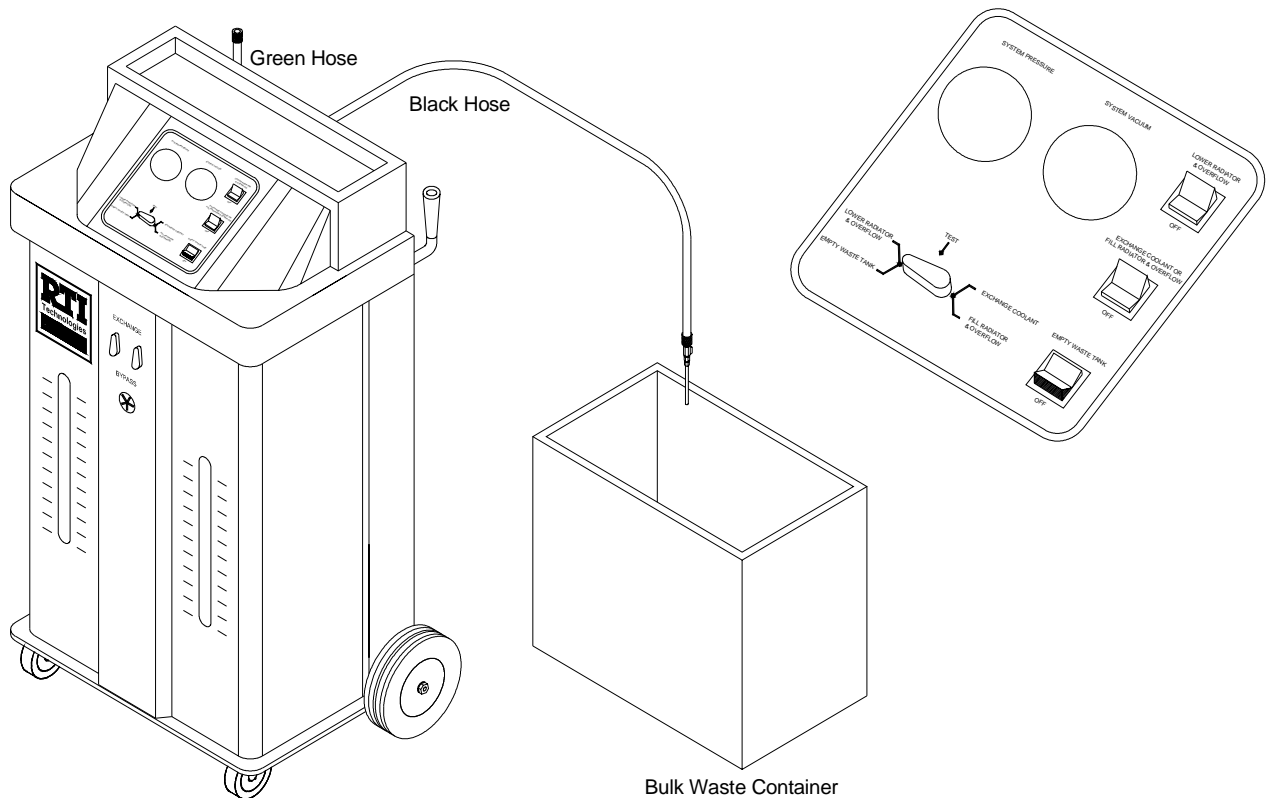



1. Install the Wand on the black hose.
2. Turn both valves on the front of the MCX-2F to EXCHANGE.
3. Turn the control valve to EMPTY WASTE TANK.
4. Press the top of the EMPTY WASTE TANK selector switch to start the pump.
5. Hold the Wand over the Bulk Waste Container and open the valve.
6. Waste coolant will be pumped directly from the MCX-2F Waste Tank into the Bulk Waste Container.
7. Close the valve on the Wand when done.
8. Press the bottom of the EMPTY WASTE TANK selector switch to stop the pump.

REPLACEMENT PARTS

Call 800-468-2321 (Extension 259)

For Technical Support or Parts Ordering

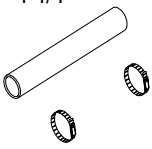
Visit our web-site at www.rtitech.com

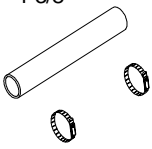
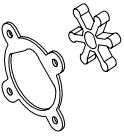
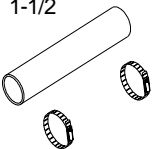
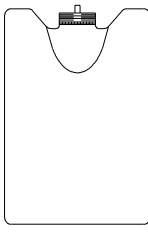
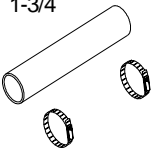
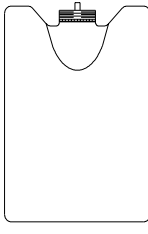
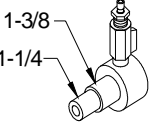
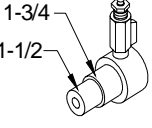
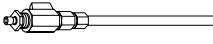
 <p>1-1/4</p>	<p>Adapter Hose (1-1/4 ID) (Includes 2 Clamps)</p>	<p>370-80009-00</p>		<p>Fuse 15 AMP</p>	<p>025-80326-00</p>
 <p>1-3/8</p>	<p>Adapter Hose (1-3/8 ID) (Includes 2 Clamps)</p>	<p>370-80010-00</p>		<p>Impeller & Gasket (For Waste Pump M2)</p>	<p>028-80210-00</p>
 <p>1-1/2</p>	<p>Adapter Hose (1-1/2 ID) (Includes 2 Clamps)</p>	<p>370-80011-00</p>		<p>New Coolant Tank</p>	<p>370-80007-00</p>
 <p>1-3/4</p>	<p>Adapter Hose (1-3/4 ID) (Includes 2 Clamps)</p>	<p>370-80012-00</p>		<p>Waste Tank</p>	<p>370-80036-00</p>
 <p>1-3/8 1-1/4</p>	<p>Small Step Adapter</p>	<p>370-80004-00</p>			
 <p>1-3/4 1-1/2</p>	<p>Large Step Adapter</p>	<p>370-80005-00</p>			
	<p>Wand</p>	<p>370-80006-00</p>			

RTI TECHNOLOGIES, INC.

4075 East Market Street

York, Pennsylvania 17402

Fax: 717-755-8304

WASTE PUMP IMPELLER REPLACEMENT

The waste pump impeller may require periodic replacement. The concentration of impurities in recovered old coolant affects the life of the pump impeller. Changing the impeller is quick and easy as follows:

1. Remove Hose Holder on rear of unit to access the end of the Waste Pump.
2. Remove 4 screws.
3. Remove cover plate, gasket and worn impeller.
4. Coat new impeller with Vaseline[®] petroleum jelly.
5. Align flats and press impeller onto shaft.
6. Attach new gasket and cover plate.
7. Replace Hose Holder.

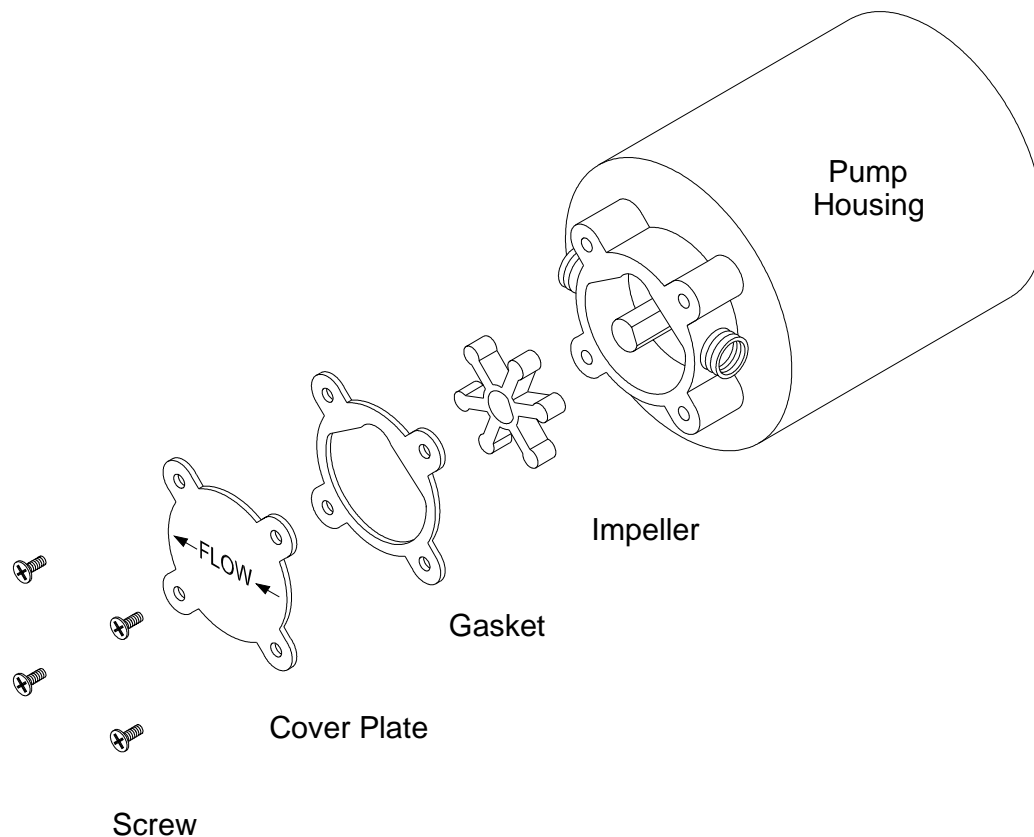

Impeller & Gasket - Part Number 028-80210-00

FLOW & WIRING DIAGRAM

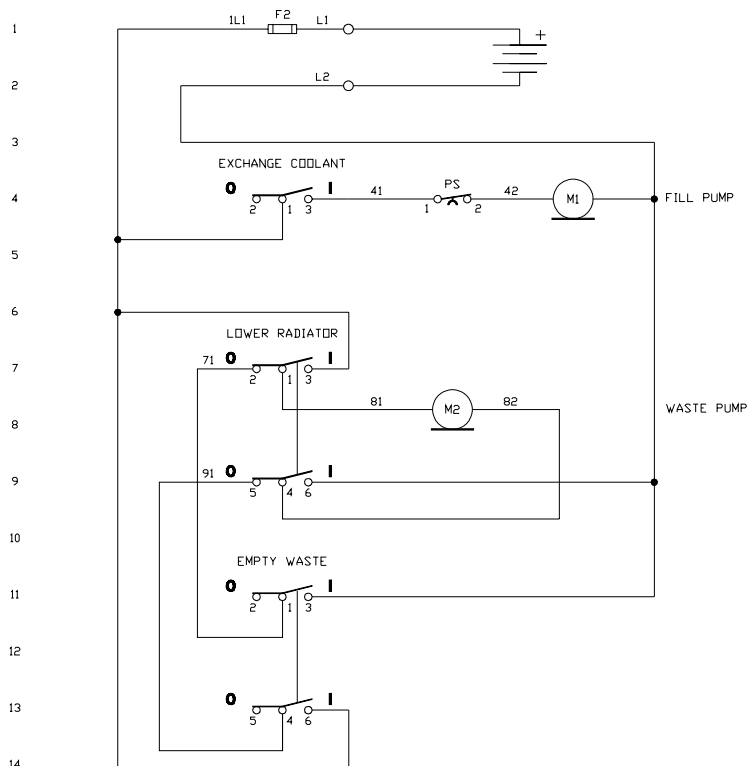
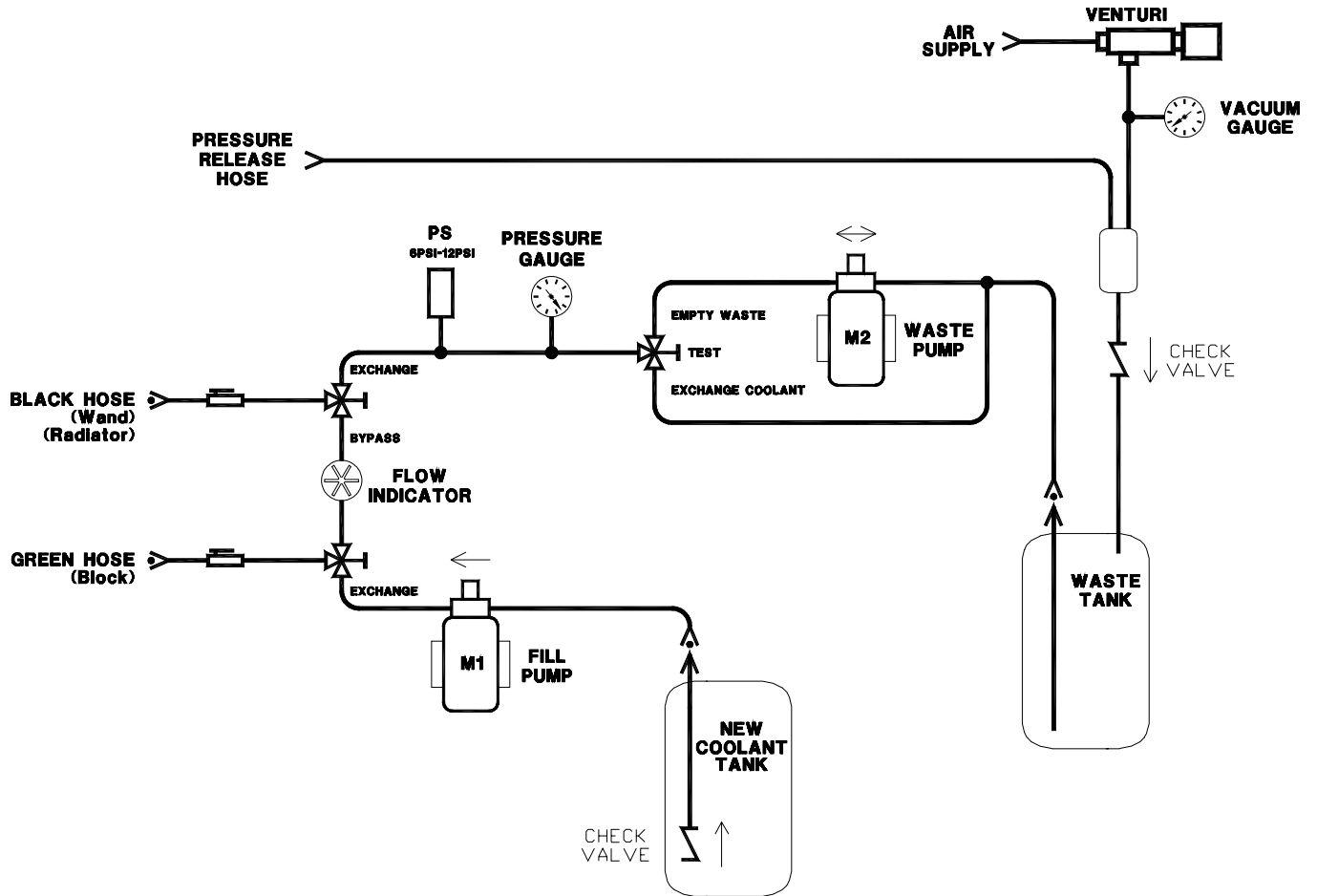

DATE: 03-18-02