

OPERATION MANUAL

NTF-15 Plus

Nitrogen Tire Filling



Valve Stem Caps (Qty=200)

Order P/N 355-80026-00



RTI Technologies, Inc

10 Innovation Drive

York, PA 17402

800-468-2321

www.rtitech.com

035-81172-00 (Rev A)

Table of Contents

Pictograms	1
Health, Safety and Environmental Aspects	1
Description of the NTF-15 Plus Membrane	2
Process Parameters	3
Unpack & Check Equipment	3
Safety Precautions	4
Operation	5
Maintenance	5
Parts Identification	7
Flow Diagram	8

Pictograms

In this manual the following pictograms are used:



Warning

A warning shows a hazard that can cause death or serious injury. Follow the instructions.



Caution

A caution shows a danger that can cause damage to the equipment. Follow the instructions.



Warning

Risk of death due to suffocation.



Risk of fire

Oxygen-enriched air leads to an increased risk of fire in the event of contact with flammable products.



High pressure risk

Follow the instructions with respect to compressed gasses.



Instructions with respect to the environment.

Health, Safety and Environmental Aspects

General

Correct use of the NTF-15 Plus nitrogen generator is important for your personal safety and for trouble-free functioning. Incorrect use can cause damage to the NTF-15 Plus or can lead to incorrect gas supply to the customer's process.



Warning

Read this manual before you start operating the NTF-15 Plus. Prevent accidents and damage.

Contact RTI if you detect a problem that you cannot solve with this manual.

Compressed air



Warning

Ensure that the feed air pressure can not exceed 190 psig.

Nitrogen and Oxygen

The NTF-15 Plus generates nitrogen as a product. Oxygen enriched air is released as waste.



Warning

Nitrogen can cause suffocation! Oxygen-enriched air leads to increased risk of fire in the event of contact with flammable products. Make sure that there is adequate ventilation at all times!

Do not install the NTF-15 Plus in an area where explosive substances may be present.

Description of the NTF-15 Plus Membrane

General

The NTF-15 Plus separates compressed air into nitrogen and an oxygen enriched air stream. The separation system is based on membrane technology. The compressed air comes from a central system or from a dedicated compressor.

The nitrogen produced is stored in the nitrogen storage vessel. The NTF-15 Plus then switches on and off, depending on the nitrogen demand.

Separation principle

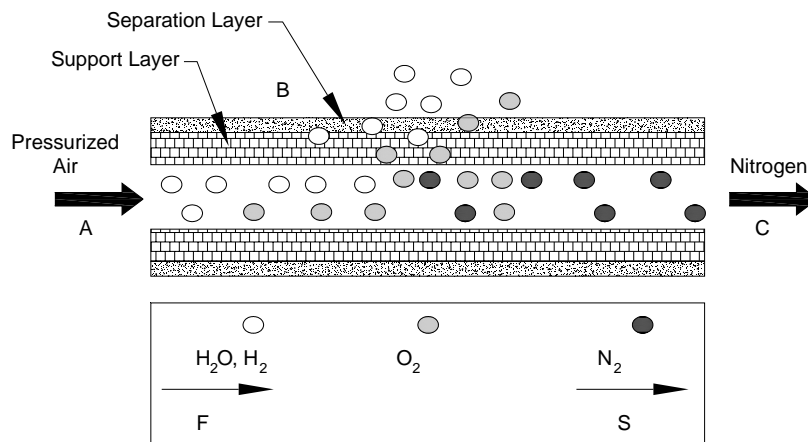

- | | | | |
|---|-----------------------|---|------|
| A | Pressurized air inlet | F | Fast |
| B | Hollow fibre membrane | S | Slow |
| C | Nitrogen outlet | | |

Ambient air contains nitrogen (78.1%), oxygen (20.9%), argon (1%), carbon dioxide, water vapor and traces of other inert gasses. Pressurized air (A) is fed through the hollow fiber membrane (B). The various air components diffuse through the wall of the membrane.

The diffusion rate differs for the various gasses:

Oxygen and water vapor have a high diffusion rate and permeate rapidly through the membrane wall.

Nitrogen has a low diffusion rate and permeates slowly through the membrane wall.

At the exit of the membrane (C), pressurized nitrogen is released.

Process Parameters

The nitrogen production depends on these parameters:

- Flow rate** The lower the flow rate of compressed air through the hollow fiber membrane, the more oxygen can permeate through the membrane wall. As a result, the nitrogen produced at the outlet will have a higher purity. Nitrogen purity can be adjusted with the flow control valve.
- Temperature** The NTF-15 Plus operates optimally at a temperature between 70-80°F. If the temperature increases, the pressurized air consumption will also increase. Do not place the system in a room where the temperature may rise unnecessarily high.
- Allow enough piping between the compressor exit and the NTF-15 Plus inlet so that the hot compressed gas has time to cool within the specifications listed in this manual.
- Membrane pressure** A higher membrane pressure will increase the capacity (i.e. nitrogen output) of the NTF-15 Plus. Pressure also enables operation of the pneumatic pressure switch.
- External pressure** There must be atmospheric pressure at the outlet. The capacity and the purity of the nitrogen gas decreases strongly if the vent pressure exceeds the atmospheric pressure.

Unpack & Check Equipment

Ensure that all components were delivered.

Ensure that the compressed air source meets specification:

Oil content of the compressed air is below 0.01mg/m³.

Ensure that the compressed air pressure and quality is always as prescribed.

Ensure that the air capacity is sufficient.

Safety Precautions



Warning

Ensure there is sufficient ventilation.

Only feed the NTF-15 Plus with air.

Keep the air feed to the NTF-15 Plus clean and free of vapors of organic solvents and other contaminants. Do not place the NTF-15 Plus in a room where organic solvent vapors may be present.

Keep the ambient temperature between 40 and 110 °F. Do not connect hot compressed air directly from a compressor to the inlet of the NTF-15 Plus.

Regular maintenance should be performed on the NTF-15 Plus to ensure proper and safe operation.

Ensure that instructions concerning health and safety are compliant with local regulations.

Environmental Aspects



The use and maintenance of the NTF-15 Plus do not include environmental dangers. Most parts are made of metal and can be disposed of in a manner consistent with local regulations.

Make sure that instructions concerning health, safety and environment are compliant with all local regulations.

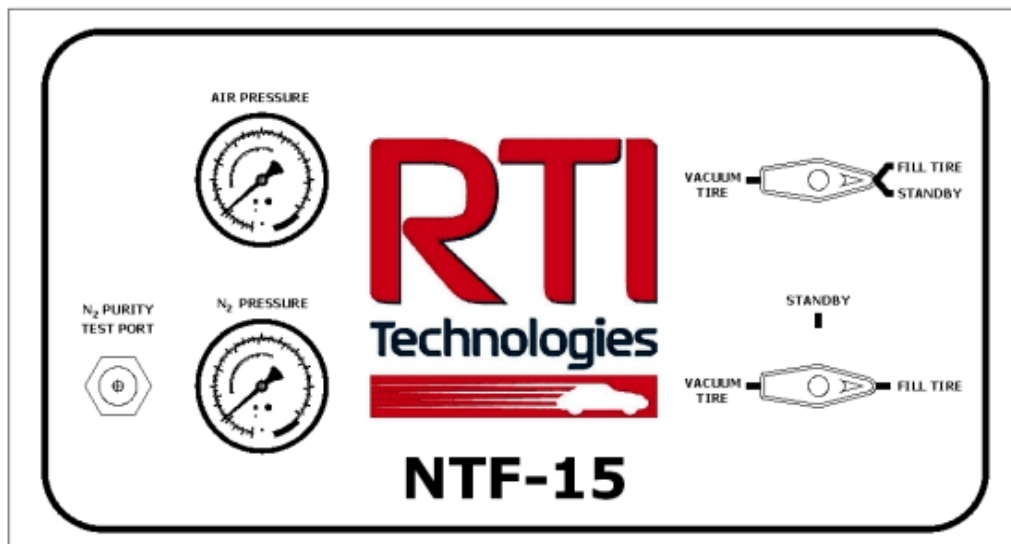

Operation (See Control Panel on Preceding Page)

Vacuum Tire

1. Connect shop air (120 - 150 PSI) to the air inlet port on the rear of the NTF-15 Plus.
2. Turn both panel valves to VACUUM TIRE.
3. Remove cap from tire valve stem. Place air chuck (on the end of the NTF-15 Plus coiled green hose) on valve stem. Squeeze air chuck trigger to vacuum tire.
4. To check for vacuum, release trigger momentarily. If slide-out pressure gauge moves out, press trigger to continue the vacuum process.
5. When slide-out pressure gauge does not move out, continue to vacuum the tire for another 10 seconds.

Fill Tire

1. Connect shop air (120 - 150 PSI) to the air inlet port on the rear of the NTF-15 Plus. Verify pressure indicated on Air Pressure gauge is between 120 - 150 PSI. Verify Nitrogen pressure indicated on the N₂ Pressure gauge is adequate for service.
2. Turn both panel valves to FILL TIRE.
3. Place air chuck (on the end of the NTF-15 Plus coiled green hose) on tire valve stem. Squeeze air chuck trigger to fill tire.
4. Momentarily release air chuck trigger and check the slide-out pressure gauge to determine pressure in the tire. Stop when tire pressure reaches the manufacturer's recommended inflation pressure. Do not over inflate.
5. Replace valve stem cap with RTI N₂ Cap (Package of 200 - Part Number 355-80026-00).

Note: While not using the NTF-15 Plus to fill or vacuum tires, generate Nitrogen and increase the Nitrogen pressure in the internal storage tank by turning both panel valves to STANDBY.

Note: While using the NTF-15 Plus, the automatic drain feature of the filters may activate to remove excess water and oil. This is normal with the standard operation of the unit.

Maintenance

Part	Action	Frequency
Filter	Replace filter element. Refer to Page 6	One time per year, or when indicator on the filter head reaches the end of the indicator bar
Automatic drain	Clean automatic drain. Refer to Page 6	When required

Replace Filter Element

Turn off the air supply.

Let the system depressurize until the pressure gauge reads 0 psi.

Unscrew the bleed screw (F) slowly to ensure that the filter is depressurized.

Turn the filter bowl (E) counter-clockwise and pull the bowl from the filter housing (A).

Unscrew the blue knob (D).

Remove the old filter element (C).

Clean the sieve (B) and the filter house, if necessary.

Install a new filter element (C).

Assemble the parts in the reverse order.

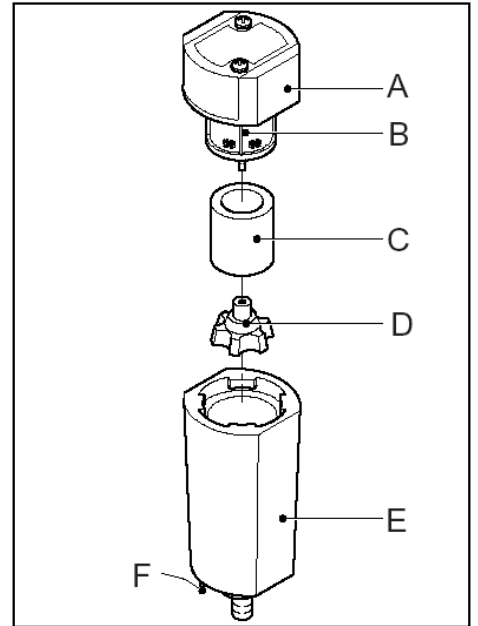

Note: A periodic check of the automatic drains is necessary to ensure the membrane life. To verify float is functioning correctly, open the filter bowl by turning one quarter turn counter-clockwise. Inspect for water or oil, an inactive float will be submerged, an active float will not. If float is found to be inactive follow cleaning procedure below or if necessary replace with part number 026-80386-00.

Clean Automatic Drain

Open the filter by turning the bowl one quarter turn counter-clockwise.

Unscrew the nut (F).

Remove the drain unit (B-E) from the filter bowl (A).

Remove the O-ring (E).

Carefully pull the floating house (B) from the seat (D). Do not bend the needle (C).

Clean the parts with soap and water. Make sure that the needle bore is open and clean.

Assemble the parts in the opposite direction. Make sure that the parts are dry before reassembly.

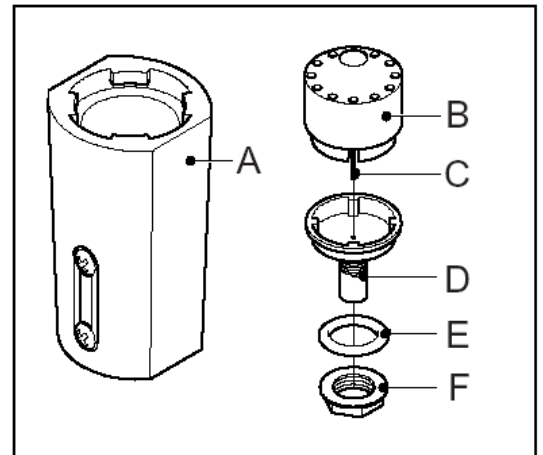

Automatic Pressure Switch Setting

The automatic pressure switch found in the is factory pre-set to shut off shop air consumption at 120 psi. This switch will then automatically reset when the N₂ Pressure inside the tank drops by approximately 25 psi.

If your application requires an inlet pressure of 100 - 119 psi an, adjustment to the automatic pressure switch is possible. Please contact RTI Technical Support at 800-468-2321 extention 259 for further details.

Parts Identification

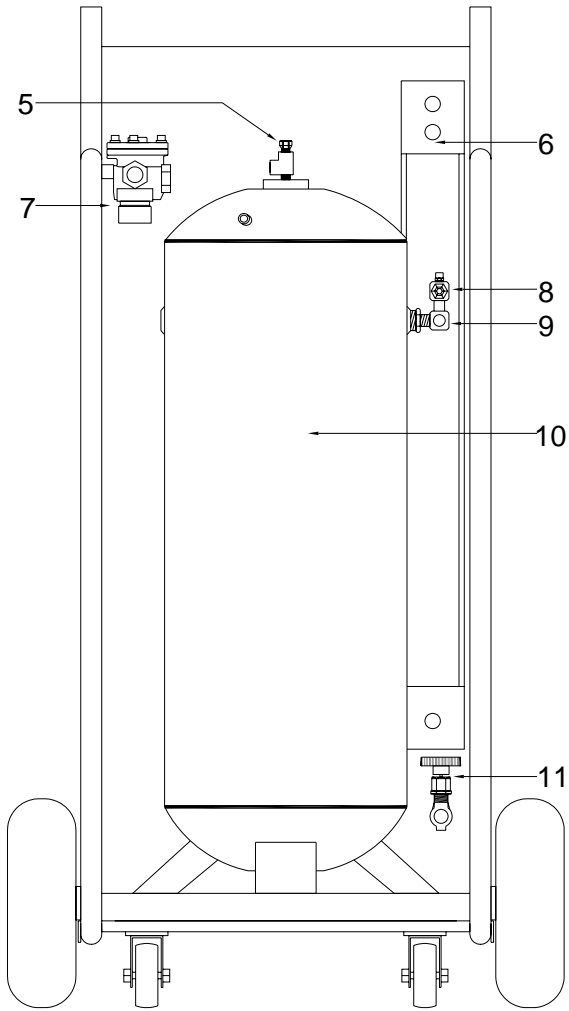
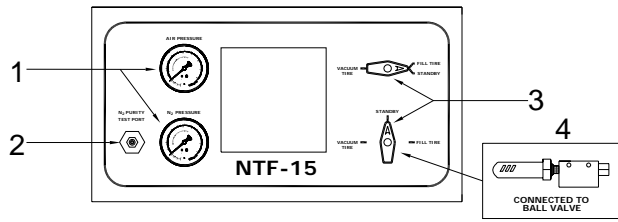

	Part Number	Description
1	026-80379-00	2" Gauge 0-160 psig/bar 1/4MPT
2	023-80364-00	FTG Test Port 1/4 MPT X valve stem
3	022-80028-00	3-way ball valve 1/4 FPT (BHD)
4	026-80330-00	pneumatic vacuum pump
5	022-80005-00	relief valve 300 psi
6	026-80384-00	nitrogen membrane (large)
7	022-80130-00	pneumatic pilot valve
8	022-80131-00	adjustable pneumatic pressure switch
9	022-80128-00	check valve 3/8 FPT
10	026-80377-00	15 gal vertical air tank
11	022-80129-00	needle valve 3/8 FPT
12	026-80381-00	water filter w/auto drain
13	026-80386-00	auto drain float
14	026-80382-00	oil filter w/auto drain
15	026-80383-00	moisture filter
16	028-80362-00	coiled green hose
17	023-80362-00	air chuck

Filter Replacement Kit
355-80025-00
(Includes Filters for Item 12, 14 and 15)

N₂ Caps (Qty=200) for Valve Stem
355-80026-00

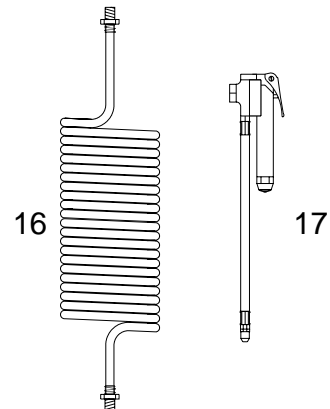
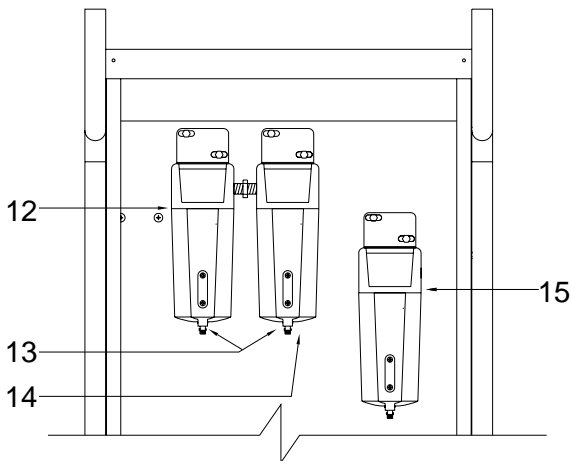

Flow Diagram

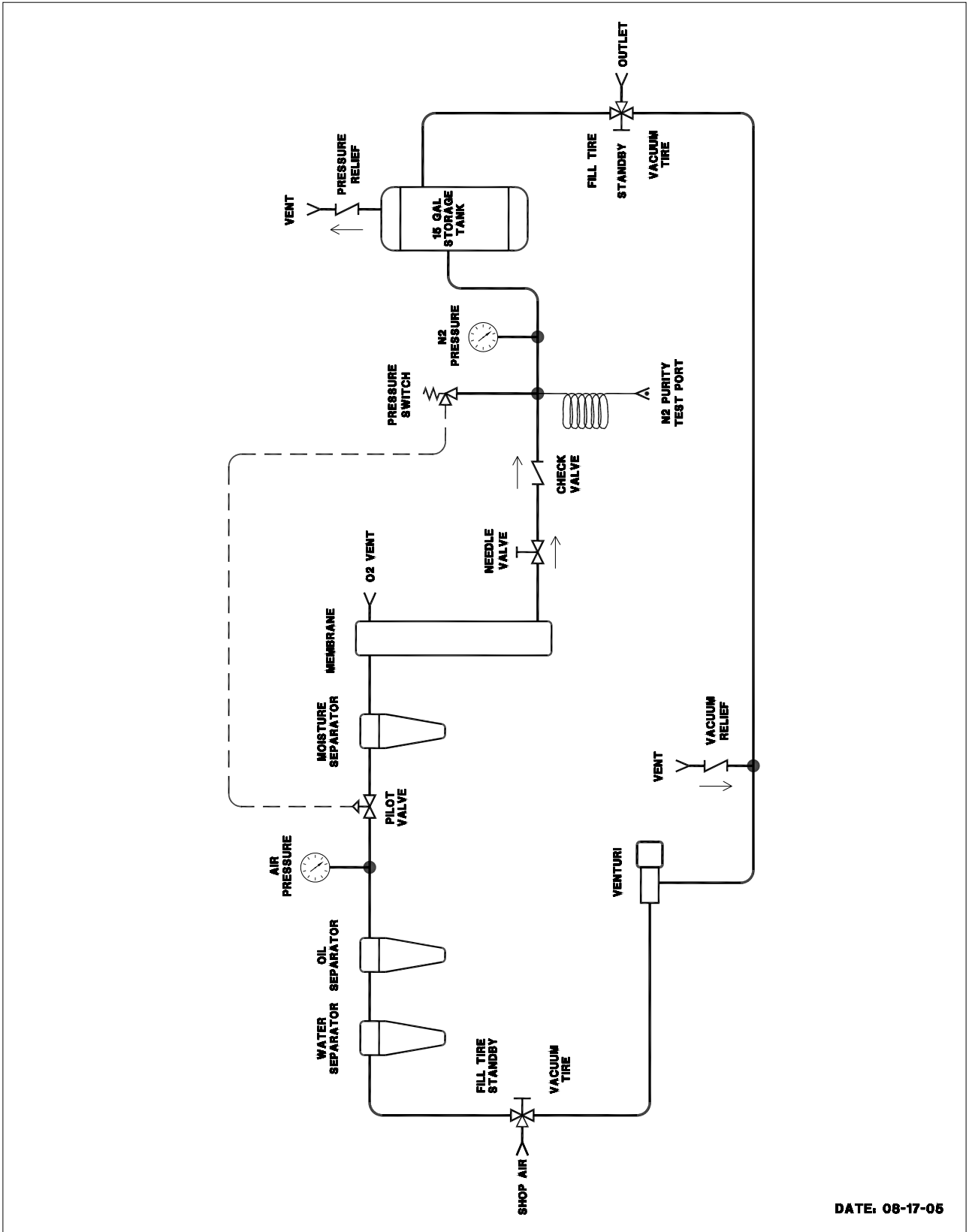

DATE: 08-17-05

NTF-15 MACHINE ELEC & FLOW (2005)

570-80317-00