

OPERATION

MANUAL

RHS2780E and RHS2780V

Dual Refrigerant Management Center

R12 & R134a



RTI TECHNOLOGIES, INC.

York, Pennsylvania

800-468-2321

035-80681-00

TABLE OF CONTENTS

Startup & Safe Operation	Page 1
Introduction to the RHS2780	Page 2
Configuration	Page 3
Control Panel	Page 4
Keypad Functions	Page 5
Fill Charge Cylinder	Page 6
Recycle	Page 7
Deep Vacuum	Page 8
Purge Air - Drain Oil	Page 9
Charge	Page 10
Automatic	Page 11
Stored Data	Page 13
Set Over Charge Amount	Page 14
Maintenance	Page 15
Parts Lists	Page 16

TECHNICAL SUPPORT

RTI Technologies has a staff of qualified technicians available for technical support. We also maintain one of the largest networks of Service Centers throughout the world for unit repairs and maintenance. Our web site is constantly updated to provide the latest information concerning all the products we manufacture.

RTI Technologies, Inc.
York, Pennsylvania

800-468-2321

www.rtitech.com

STARTUP & SAFE OPERATION

- Do not use a damaged unit. Check for shipping damage and place a claim with carrier if damage is discovered.
- Return the Warranty Card to activate technical support service and warranty coverage.
- The RHS2780 should not be operated or serviced by any person who has not read all the contents of this manual.
- This manual describes normal operation and maintenance for the RHS2780. Failure to read and comply with these instructions or any one of the limitations noted herein can result in serious injury and/or property damage. The instructions should not be interpreted to anticipate every possible contingency.
- It is the responsibility of the owner/user to operate the RHS2780 in accordance with all laws and specifications which may apply.
- Recover, recycle, and charge only the refrigerants for which the RHS2780 is configured.
- Avoid breathing refrigerant or lubricant vapor. Exposure may irritate eyes, nose and throat. Ventilate work area if accidental system discharge occurs.
- Wear safety glasses and protective gloves. Refrigerant has a very low boiling point and can cause frostbite.
- Follow the RHS2780 operating procedures sequentially to avoid prematurely disconnecting hoses or opening valves which may release refrigerant to the atmosphere.
- Do not expose the RHS2780 to moisture or operate in wet areas.
- Use the RHS2780 in locations with ventilation that provides at least four air changes per hour.
- Hoses must have shutoff devices within 12 inches of the connection point to the A/C to minimize the introduction of air into the RHS2780 and the release of refrigerant when being disconnected.
- Avoid using an extension cord with the RHS2780. If necessary use a good condition, three wire grounded, #14 AWG or larger extension cord of the shortest possible length.
- Disconnect power before performing any maintenance or service on the RHS2780.
- Do not connect the red or blue hoses to the liquid port of a cylinder of refrigerant to fill the charge cylinder. Doing so may cause the compressor to fail and void the warranty.
- Do not connect the RHS2780 to the liquid side of any A/C with a capacity greater than 4 lbs. Refrigerant in A/C Systems having larger capacities must be recovered from the vapor side only.

Special Considerations with R134a

R134a has been shown to be nonflammable at ambient temperature and atmospheric pressure. However, tests under controlled conditions have indicated that at pressures above atmospheric and with air concentrations greater than 60 percent by volume, R134a can form combustible mixtures.

While it is recognized that an ignition source is also required for combustion to occur, the presence of combustible mixtures is a potentially dangerous situation and should be avoided.

Under no circumstances should any equipment be pressure tested or leak tested with air and R134a mixtures. Do not use compressed air for leak detection in R134a systems.

INTRODUCTION TO THE RHS2780

The RHS2780 is a complete dual refrigerant management center featuring state-of-the-art solid state control with digital weight scale measuring of refrigerant. Operation of the RHS2780 is intuitive and very easy to master. Operational functions of the RHS2780 can be performed individually or in an automatic sequence.

This Operation Manual first describes each of the functions and then gives an overview of combining the functions into an automatic sequence. Some functions have options where the controller display will prompt the technician for input during the setup programming.

Following is an overview of the operation and features of the RHS2780:

FILL CHARGE CYLINDER

Liquid recycled or new refrigerant is quickly transferred from a cylinder on the rear of the RHS2780 to the internal charge cylinder. Following the first setup filling or a calibration procedure, 1.1 lbs. more refrigerant than displayed is used due to priming of internal components.

RECYCLE

Refrigerant is recovered from the A/C, impurities (particulates, oil, moisture and air) are removed and the refrigerant is stored in the internal charge cylinder. The recovery process stops when the RHS2780 senses a 15 InHg vacuum at the A/C. A programmable wait time (minimum of two minutes) then starts. If pressure in the A/C rises during this time period due to vaporization of residual liquid refrigerant, the RHS2780 will restart to recover this refrigerant. When the RHS2780 stays off continually for the full wait time, the recovery procedure is complete.

DEEP VACUUM

The length of time for the deep vacuum procedure is programmable. The time remaining is displayed during the deep vacuum procedure. An optional vacuum leak test and add oil function are available during the programming of the deep vacuum procedure. The technician is prompted for a Yes/No response to each. The vacuum leak test starts after the vacuum process is completed. The amount of time the vacuum is held is displayed so the technician can monitor the pressure for any increase due to a leak in the A/C. The add oil process prompts the technician to add oil after the vacuum and/or vacuum leak test procedure.

PURGE AIR - DRAIN OIL

Excess air and recovered oil must be removed from the RHS2780 after all refrigerant has been recovered from the A/C. Temperature and pressure readings are examined and air is released using the purge switch. Oil is drained into the oil drain bottle for measuring to determine the need to replenish the A/C.

STORED DATA

The RHS2780 monitors filter life and will prompt the technician when filters need to be replaced. Recycled and charged refrigerant amounts are recorded and totaled during each A/C service procedure. These totals can be monitored to manage refrigerant usage. Refrigerant transferred directly into the charge cylinder from the fill port is not added to the total recycled refrigerant.

OVER CHARGE AMOUNT

A one ounce over charge is added during each charge procedure to compensate for refrigerant loss in the service hoses. This can be programmed to accommodate different operating conditions.

CONFIGURATION

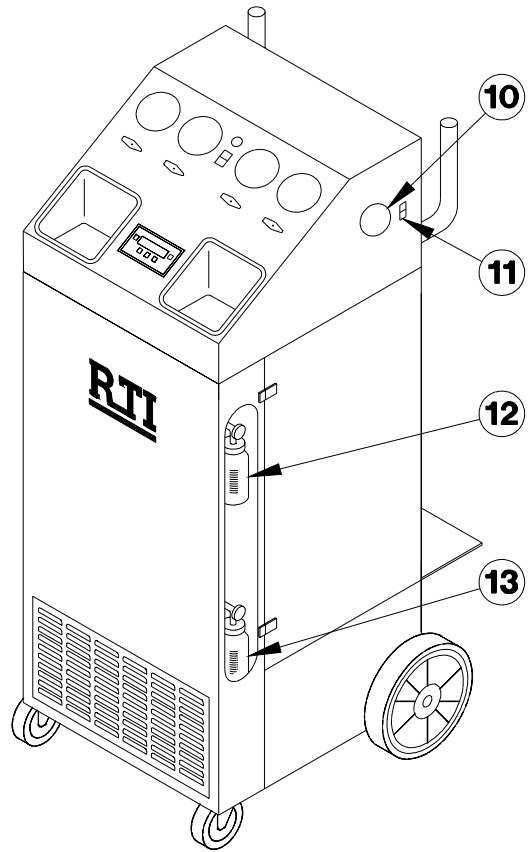
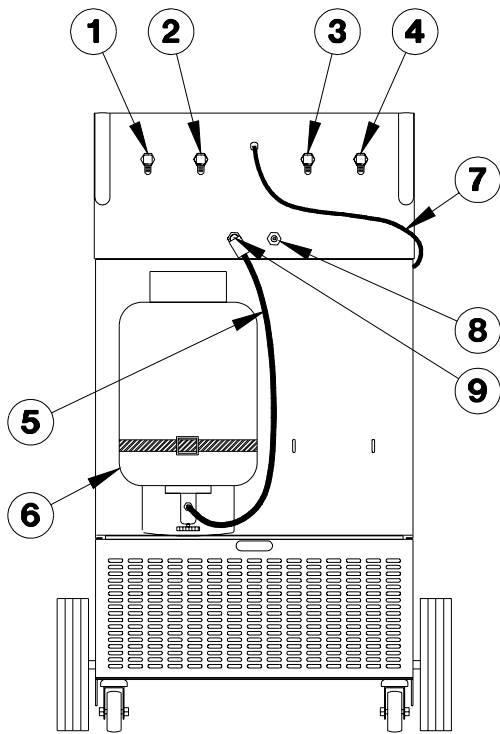

- | | | | |
|---|---|----|-------------------|
| 1 | Port for R134a High Side Red Hose | 10 | Purge Gauge |
| 2 | Port for R134a Low Side Blue Hose | 11 | Purge Switch |
| 3 | Port for R12 High Side Red Hose | 12 | Oil Charge Bottle |
| 4 | Port for R12 Low Side Blue Hose | 13 | Oil Drain Bottle |
| 5 | Yellow Hose (R134a - With Anti-Blowback Valve) | | |
| 6 | Cylinder of New Refrigerant | | |
| 7 | Power Cord | | |
| 8 | Fill Port for R12 (Attach Ball Valve end of Yellow Hose to port) | | |
| 9 | Fill Port for R134a (Attach Anti-Blowback Valve end of Yellow Hose to port) | | |

Notes: Item 6 - Cylinder of new or recycled refrigerant must be connected to put LIQUID refrigerant into the Fill Port.

Item 8 & 9 - End of Yellow Hose with anti-blowback valve (R134a) or ball valve (R12) must be connected to the respective Fill Port to prevent release of refrigerant when the hose is disconnected.

Item 12 - Oil Charge Bottle can be connected to either of two ports: one to charge oil to the high side of the A/C and the other to charge oil to the low side of the A/C.

CONTROL PANEL

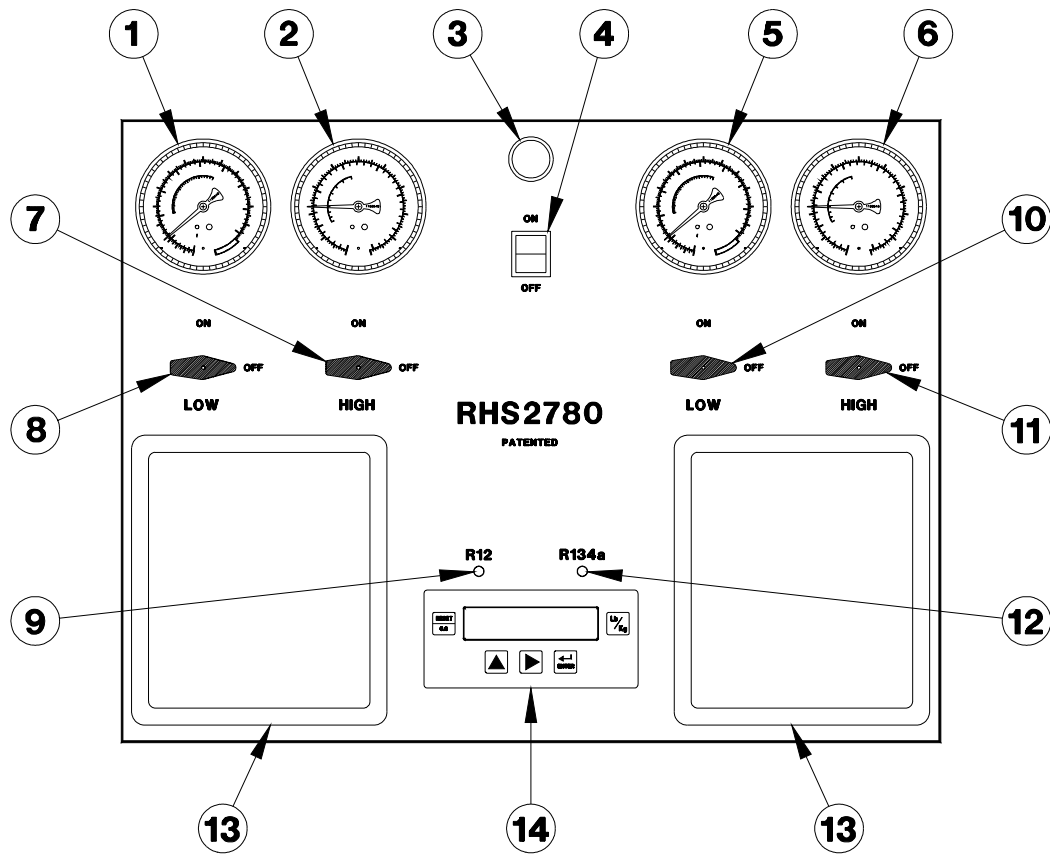

- 1 Low Pressure Gauge - R12
- 2 High Pressure Gauge - R12
- 3 Attention Indicator Light
- 4 Power Switch - Illuminated
- 5 Low Pressure Gauge - R134a
- 6 High Pressure Gauge - R134a
- 7 High Side In/Out Valve - R12
- 8 Low Side In/Out Valve - R12
- 9 Function Indicator Light - R12 selected with Cursor Key
- 10 Low Side In/Out Valve - R134a
- 11 High Side In/Out Valve - R134a
- 12 Function Indicator Light - R134a selected with Cursor Key
- 13 Tool Tray
- 14 Keypad

KEYPAD FUNCTIONS

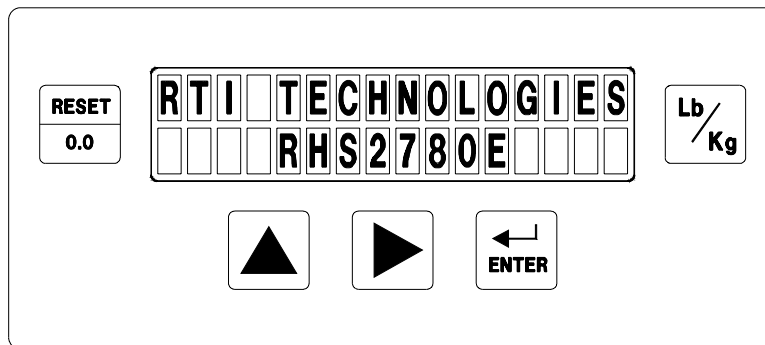

Scroll Key

Press to scroll through function options or to increase numeric values shown on the display.



Cursor Key

Press to scroll flashing cursor on the display prior to numeric or Yes/No entries. Also used to select R12 or R134a refrigerant.



Enter Key

Press to confirm data entry.



Reset Key

Press to halt program sequence and return to Main Menu.



Units Key

Press to change unit of measure for weight displays.

- CAUTION -

**Always use fingers to operate keypad.
Use of sharp objects will cause damage.**

FILL CHARGE CYLINDER

This procedure is used to quickly transfer refrigerant from a cylinder of recycled or new refrigerant into the RHS2780 charge cylinder. The fill process will continue until the charge cylinder fills to 13 lbs. Press the [RESET] key during the fill process if a smaller total amount of refrigerant is desired.

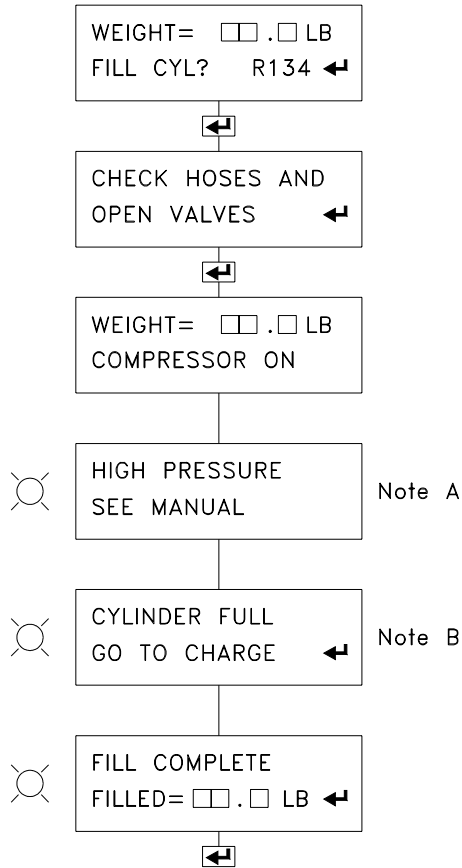

1. Connect a cylinder of recycled or new refrigerant to the appropriate fill port on the rear of RHS2780 using the yellow hose. An adapter is provided to permit connection to a cylinder of R134a having a 1/4 flare fitting.

Liquid refrigerant must be transferred into the charge cylinder. Therefore, connect to the liquid port of a DOT cylinder of recycled refrigerant and leave cylinder upright or connect to the port of new refrigerant and invert cylinder.

2. Open valve on cylinder connected to the fill port.
3. Turn on power.
4. Press [▲] key four times.
5. Observe displays as shown to the left and enter data when prompted.
6. Press [←] key to move from one display to the next.

Data Entry & Error Messages

The fill process will stop if the cylinder of recycled or new refrigerant is emptied. Press the [RESET] key to return to the main menu.

HIGH PRESSURE - SEE MANUAL (Note A)

This message will be displayed periodically during the fill process. Do not be concerned as this is normal.

CYLINDER FULL - GO TO CHARGE (Note B)

If the charge cylinder fills to the maximum capacity of 17.5 lbs. during the fill process this message will be displayed. Press the [←] key to return to the main menu and go to the charge procedure to transfer refrigerant to an A/C or an external cylinder.

RECYCLE

1. Connect red and blue hoses to A/C and open valves.
2. Turn on power.
3. Press [▲] key one time.
4. Observe displays as shown to the left and enter data when prompted.
5. Press [←] key to move from one display to the next.

Data Entry & Error Messages

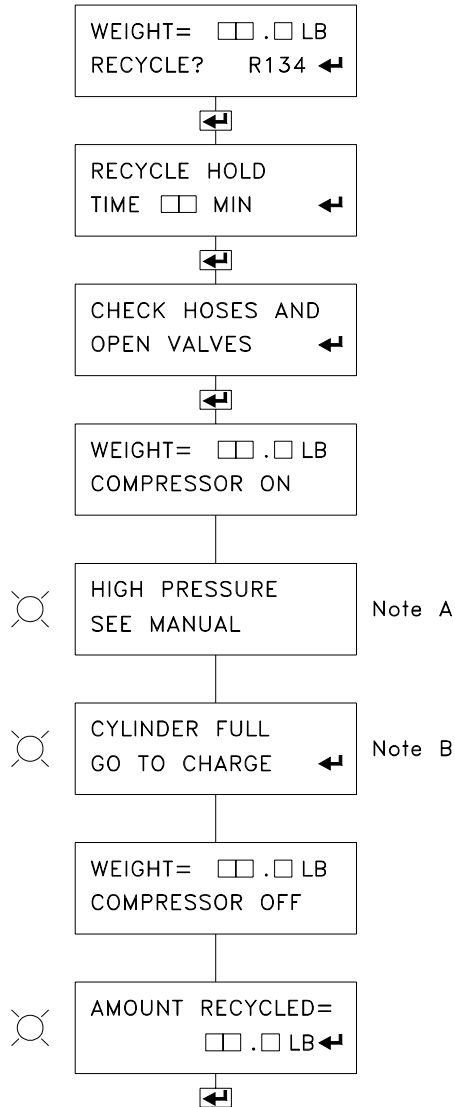

RECYCLE HOLD TIME

The RHS2780 will recover refrigerant from the A/C until a stable vacuum is sensed for at least two minutes. Times greater than two minutes can be entered for the recycle hold time. The time entered will be saved as the default.

HIGH PRESSURE - SEE MANUAL (Note A)

A condition of high pressure during the recycle process will cause this message to be displayed. Turn the power off and contact RTI Technical Service for assistance.

CYLINDER FULL - GO TO CHARGE (Note B)

If the charge cylinder fills to a maximum capacity of 17.5 lbs. during the recycle process this message will be displayed. Press the [←] key to return to the main menu and go to the charge procedure to transfer refrigerant to an external cylinder.

DEEP VACUUM

1. Connect red and blue hoses to A/C and open valves.
2. Turn on power.
3. Press [**▲**] key two times.
4. Observe displays as shown to the left and enter data when prompted.
5. Press [**←**] key to move from one display to the next.

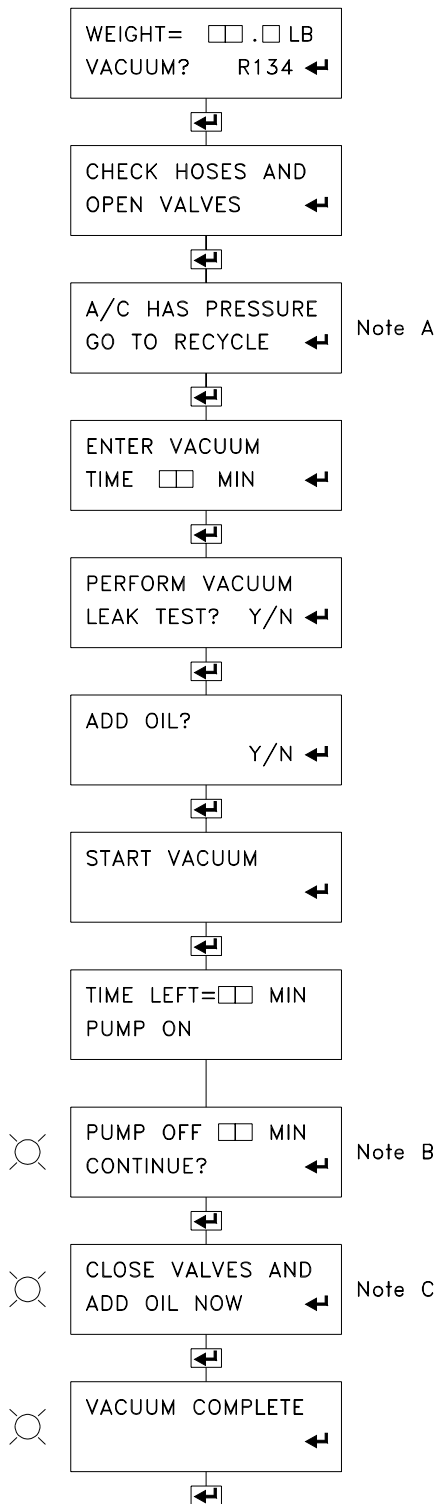

Data Entry & Error Messages

A/C HAS PRESSURE - GO TO RECYCLE (Note A)

This message will be displayed if there is still refrigerant in the A/C. This refrigerant must be recycled before a deep vacuum can be performed.

ENTER VACUUM TIME

Sets total time a vacuum will be drawn on the A/C.

PERFORM VACUUM LEAK TEST (Note B)

Yes - process will stop to allow checking for leaks. The display will show total time since the vacuum pump shut off. A leak is indicated if by an increasing pressure on the gauges.

ADD OIL (Note C)

Yes - process will stop so that oil can be added. Attach a filled oil charge bottle to either the low or high oil charge port. When prompted, close In/Out valves and open the valve on the bottle until the desired amount of oil is drawn into the A/C. Go immediately to the charge process.

PURGE AIR - DRAIN OIL

°F	R12	R134a
30	42	40
32	44	42
34	46	44
36	48	46
38	50	49
40	52	51
42	54	54
44	57	56
46	59	59
48	61	61
50	64	64
52	66	67
54	69	70
56	72	72
58	74	76
60	77	78
62	80	82
64	83	85
66	85	88
68	88	92
70	92	95
72	95	97
74	98	104
76	102	107
78	105	110
80	108	114
82	112	118
84	115	123
86	118	127
88	123	130
90	127	135
92	130	140
94	135	145
96	138	148
98	143	153
100	147	157
102	150	163
104	155	167
106	160	173
108	165	180
110	168	185
112	173	190
114	178	195
116	183	200
118	188	207
120	193	213

Purge Chart

IMPORTANT: Air must be purged and oil drained after each recycle procedure. Failure to do so will cause excess air to be introduced into the A/C during charge and the RHS2780 will fill with excess oil causing serious operational problems.

During automatic operation only, the RHS2780 will stop after the deep vacuum procedure and display **PURGE AIR AND DRAIN OIL** as a reminder.

1. Turn on power.
2. Press the purge switch for five seconds.
3. **Slowly** open valve on oil drain bottle to drain oil. Leave valve open and go to next step.
4. Measure the room temperature.
5. Find the corresponding pressure for this temperature on the appropriate R12 or R134a purge chart.
6. Compare this pressure from the chart with that indicated on the purge gauge on the side of the RHS2780. If the gauge shows a higher pressure, press the purge switch until the pressure drops to the pressure shown in the chart.
7. Close the valve on the oil drain bottle.
8. Press the purge switch for five seconds to complete the purge procedure.

CHARGE

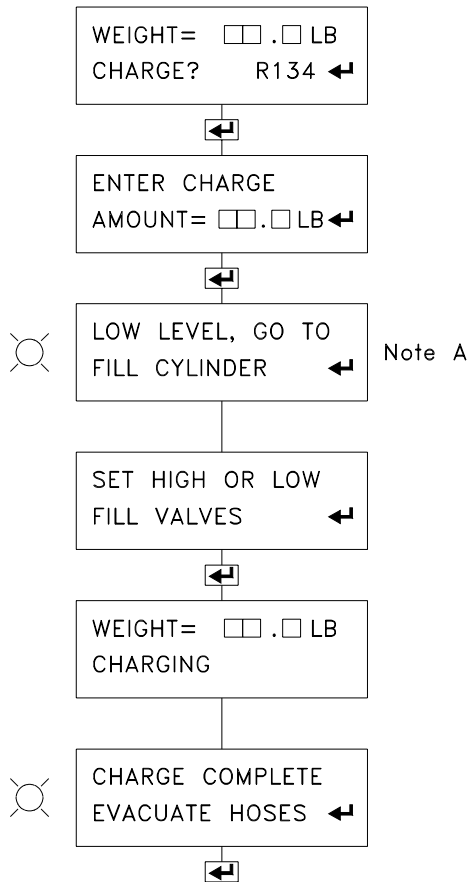

1. Connect red and blue hoses to A/C and open both hose valves.
2. Open either the low or high side In/Out valve on the RHS2780 according to the A/C manufacturer's recommendation for charging the system.
3. Do not run the A/C during the charge procedure.
4. Turn on power.
5. Press [▲] key three times.
6. Observe displays as shown to the left and enter data when prompted.
7. Press [←] key to move from one display to the next.

Data Entry & Error Messages

ENTER CHARGE AMOUNT

Enter the charge amount according to the manufacturer's specification.

LOW LEVEL, GO TO FILL CYLINDER (Note A)

This message will be displayed if the amount of refrigerant in the RHS2780 charge cylinder is less than the charge amount entered.

Press [←] key to return to the main menu. Go to the Fill Cylinder procedure to add refrigerant to the charge cylinder.

CHARGE COMPLETE - EVACUATE HOSES

This screen is displayed at the completion of the charge procedure. Press [←] key to return to the main menu.

Both high and low In/Out valves on the RHS2780 can now be closed. Start the A/C and monitor the performance.

Close both hose valves when A/C performance monitoring is complete. Disconnect hoses from A/C. A recycle procedure should be performed to evacuate refrigerant from the hoses.

AUTOMATIC

1. Connect red and blue hoses to A/C and open valves.
2. Turn on power.
3. Press [←] key to select automatic mode.
4. Observe displays as shown to the left and enter data when prompted.
5. Press [←] key to move from one display to the next.

Data Entry & Error Messages

RECYCLE HOLD TIME

The RHS2780 will recover refrigerant from the A/C until a stable vacuum is sensed for at least two minutes. Times greater than two minutes can be entered for the recycle hold time. The time entered will be saved as the default.

ENTER VACUUM TIME

Sets total time a vacuum will be drawn on the A/C.

PERFORM VACUUM LEAK TEST

Yes - process will stop to allow checking for leaks.

ADD OIL

Yes - process will stop so that oil can be added.

ENTER CHARGE AMOUNT

Enter the charge amount according to the manufacturer's specification.

LOW LEVEL, GO TO FILL CYLINDER (Note A)

This message will be displayed if the amount of refrigerant in the RHS2780 charge cylinder is less than the charge amount entered.

Press [←] key to return to the main menu. Go to the Fill Cylinder procedure to add refrigerant to the charge cylinder.

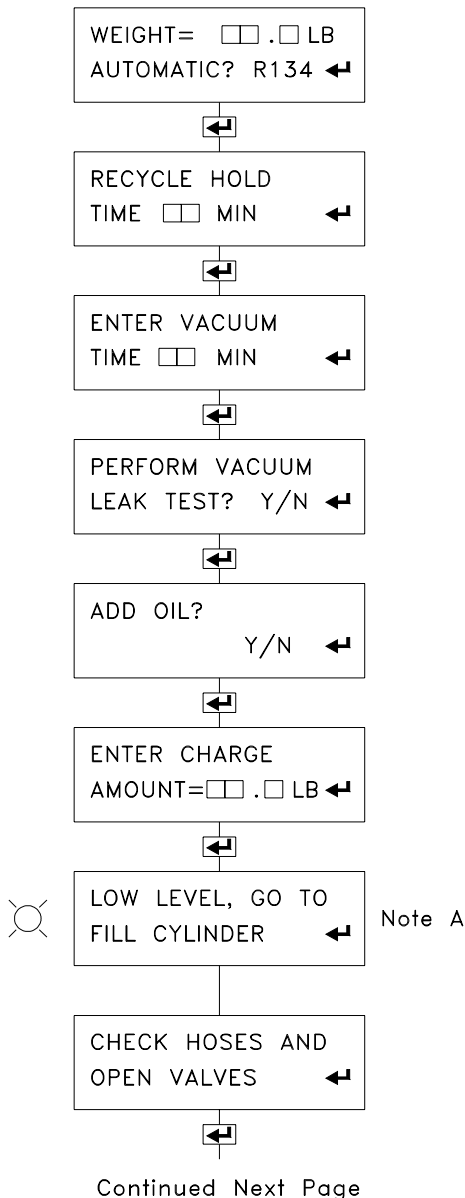

AUTOMATIC (Continued)

Continued From Previous Page

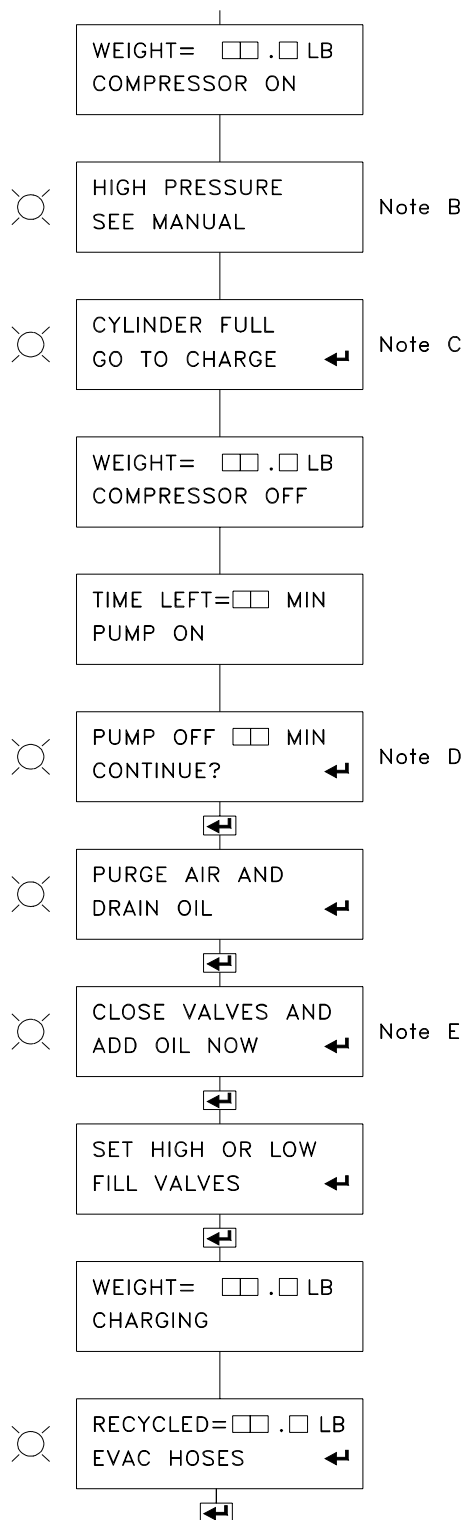

HIGH PRESSURE - SEE MANUAL (Note B)

A condition of high pressure during the recycle process will cause this message to be displayed. Turn the power off and contact RTI Technical Service for assistance.

CYLINDER FULL - GO TO CHARGE (Note C)

If the charge cylinder fills to a maximum capacity of 17.5 lbs. during the recycle process this message will be displayed. Press the [←] key to return to the main menu and go to the charge procedure to transfer refrigerant to an external cylinder.

PUMP OFF MIN - CONTINUE (Note D)

Process will stop to allow checking for leaks if Y was entered at PERFORM VACUUM LEAK TEST on previous page. The display will show total time since the vacuum pump shut off. A leak is indicated if by an increasing pressure on the gauges.

PURGE AIR AND DRAIN OIL

Process will stop so that air can be purged and oil drained. Refer to previous section on purging air and draining oil for instructions.

IMPORTANT: Air must be purged and oil drained. Failure to do so will cause excess air to be introduced into the A/C during charge and the RHS2780 will fill with excess oil causing serious operational problems.

CLOSE VALVES AND ADD OIL NOW (Note E)

Process will stop so that oil can be added if Y was entered at ADD OIL? on previous page. Attach a filled oil charge bottle to either the low or high oil charge port. When prompted, close In/Out valves and open the valve on the bottle until the desired amount of oil is drawn into the A/C.

STORED DATA

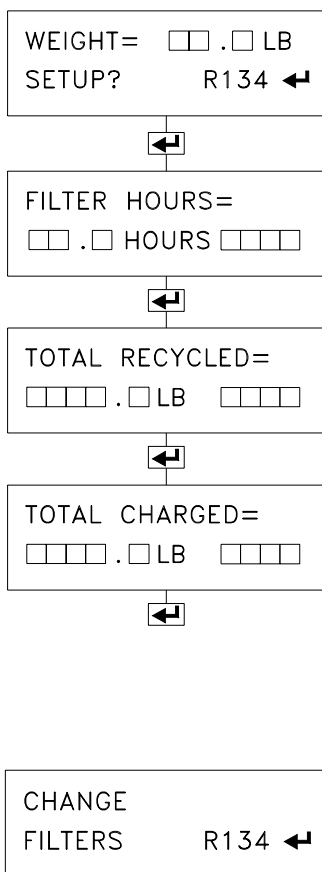

1. Turn on power.
2. Press [▲] key five times.
3. Observe displays as shown to the left.
4. Press [←] key to move from one display to the next.

Information Displayed

FILTER HOURS

This display shows total hours that refrigerant has been recycled through the filtering system of the RHS2780.

After every 25 hours, the display (shown to the left) will remind the technician that one or both filters should be changed as soon as possible. This will be displayed continually, prior to the main menu until reset.

Refer to the section on maintenance for instructions on changing filters.

The CHANGE FILTER message should then be reset as follows:

While the FILTER HOURS message is displayed, press and hold the [▶] key and then press the [RESET] key.

TOTAL RECYCLED

The total refrigerant recycled by the RHS2780 is displayed. This total can not be reset to zero.

This total does not include refrigerant added directly to the charge cylinder through the rear fill port.

TOTAL CHARGED

The total refrigerant charged by the RHS2780 is displayed. This total can not be reset to zero.

SET OVER CHARGE AMOUNT

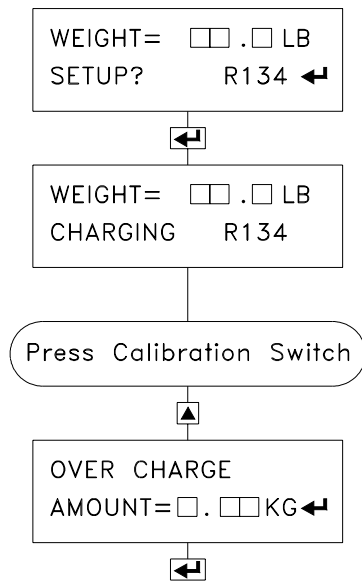

A one ounce over charge is added during each charge procedure to compensate for refrigerant loss in the service hoses. This can be programmed to accommodate different operating conditions as follows:

1. Remove rear panel by releasing the two black latches on each side of the RHS2780.
2. Close all valves and turn on power.
3. Press [▲] key five times.
4. Observe displays as shown to the left and refer to the illustration below for the following steps.
5. Look into RHS2780 from R12 side and locate metal covered circuit board located between the tool trays on the underside of the top panel.
6. Remove calibration tool.
7. Insert un-threaded end of calibration tool into access hole and GENTLY PRESS the calibration switch.
8. Press [▲] key one time.
9. Enter amount desired for over charge - note the unit of measure is kg. (1 ounce = 0.02835 kg)
10. Press [←] key to accept the new value for over charge.
11. Replace calibration tool and rear panel.

Calibration Tool Part Number 360-81214-00

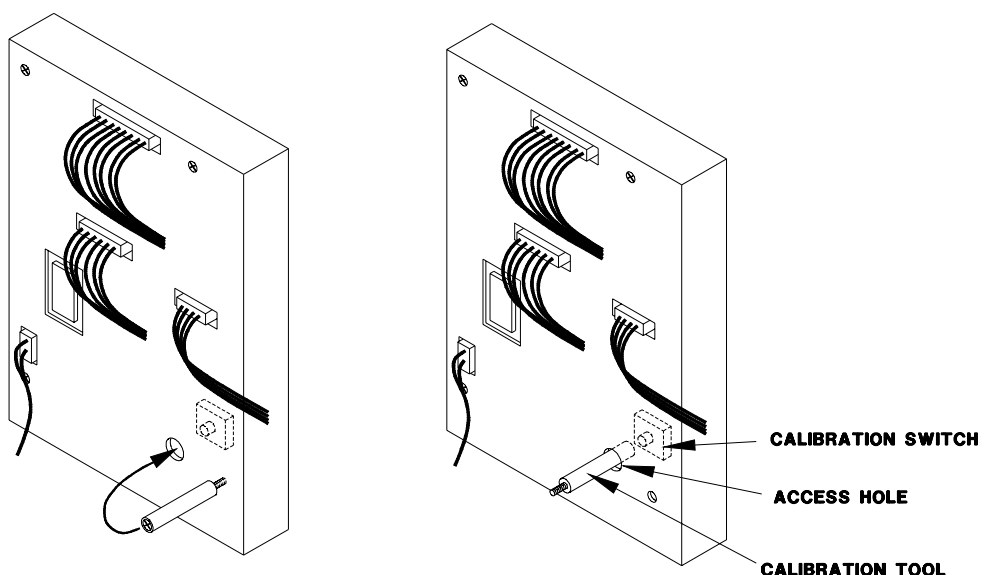

MAINTENANCE

The RHS2780 will provide many years of faithful service if properly maintained. Following is a checklist of items which will ensure the RHS2780 performs at peak efficiency and presents an image to your customers that your shop performs high tech A/C service.

- Use tool trays for storage of tools and accessory adapters. Do not place tools on the upper surface of the unit.
- Coil and hang hoses on the handles when not in use. Avoid hanging hoses over the top of the unit.
- Keep the exterior surfaces clean. Use a mild all purpose cleaner to wipe oil and dirt off the cabinet.
- Do not allow the unit to sit outside in direct sunlight or inclement weather. Excessive moisture may cause damage and will void the warranty.
- The RHS2780 is not intended to be used for mobile A/C service where the unit is transported to customer sites. Excessive vibration will shorten component life.
- Be gentle when moving the RHS2780 around the shop. Tip the unit and ease the front casters over any obstacles such as door jams and potholes.
- Periodically remove the rear cover and check for refrigerant leaks inside the RHS2780 using a leak detector. A small leak found early will prevent future undetected loss of refrigerant.
- Use regulated, clean shop air to remove debris from the fins of the condenser coils. Be careful and do not disturb any internal components.
- Periodically remove front louvered panel and check oil levels in both compressors. Oil should be visible in the oil sight tube when the compressor is not operating. If oil is not visible, call RTI Technical Support 800-468-2321.
- Periodically check the oil level in the vacuum pump (RHS2780V model only). Oil should be visible half way up the sight glass while the vacuum pump is running. If the oil level is low, call RTI Technical Support 800-468-2321.
- Change filters when the display indicates a filter change is due.

FILTER CHANGE

After every 25 hours, the display will remind the technician that filters should be changed as soon as possible. This will be displayed continually, prior to the main menu until reset. There are two filters on each side of the RHS2780. The large inlet filters must be changed after every 25 hours while the smaller outlet filters must be changed after every 50 hours.

Turn power off and remove rear cover to change filters. The foam insulation on the smaller outlet filter must be removed from the old filter and installed on the new one.

Check for leaks after replacing filters.

Reset the change filter message as described in the stored data section.

Inlet Filter P/N 026-80077-00

Outlet Filter P/N 026-80069-00

PARTS LIST - R12 SIDE

RHS2780E

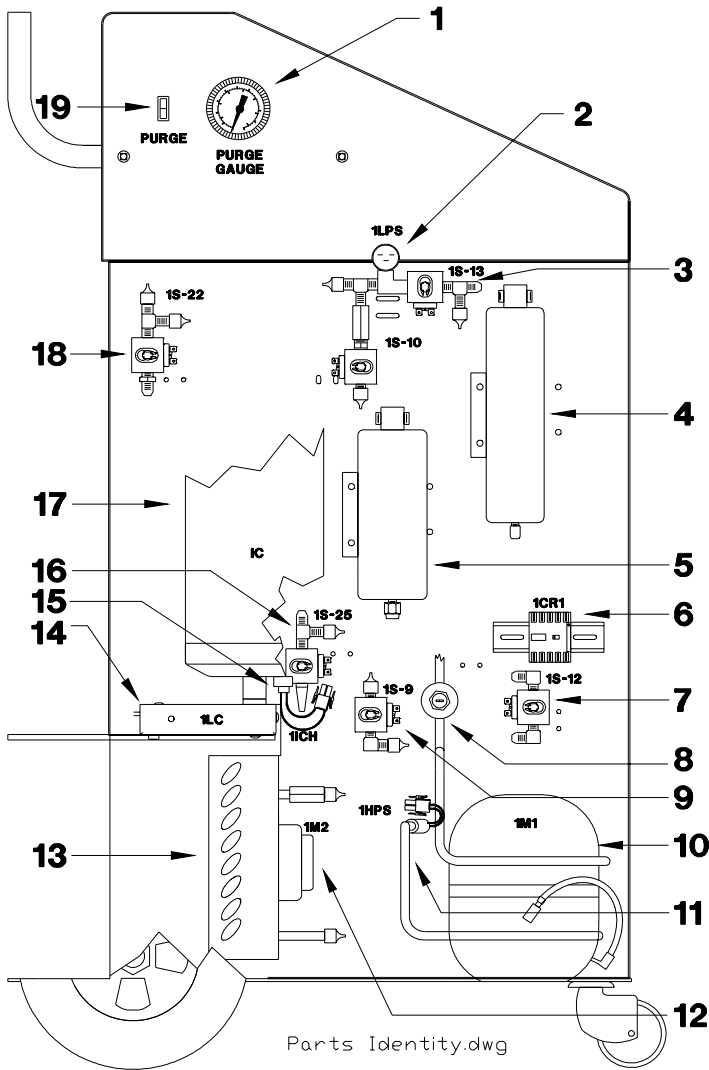

	PART NO.	DESCRIPTION
1	360-80260-00	Gauge Assy 0-500 PSIG
2	360-81314-00	Low Pressure Switch 3 Psig/15 InHg
3	360-81375-00	Manifold Assy R12 120V
4	026-80077-00	Filter 3/8 Flare (Long)
5	026-80069-00	Filter 3/8 Flare (Short)
6	024-80037-00	Contactorr ½ HP 120V 3 NO & 1NC
7	360-81381-00	Solenoid Assy 1S12 120V
8	360-81389-00	Tube Assy Compressor Inlet R12
9	360-81379-00	Solenoid Assy 1S9 120V
10	360-81356-01	Compressor Assy 120V
11	360-81307-00	High Pressure Switch 261 PSIG
12	360-80416-00	Fan Assy w/Pin Terminals 120V
13	360-81344-00	Cond Fan Assy 120V
14	031-80001-00	Load Cell 35Kg (with Support Assy)
15	360-81337-01	Heater Assy 120V
16	360-81385-00	Solenoid Assy 1S25 120V
17	360-81321-01	Charge Cylinder Assy 120V
18	360-81383-00	Solenoid Assy 1S22 120V
19	024-80035-00	Rocker Switch SPST (Momentary On)

PARTS LIST - R134a SIDE

RHS2780E

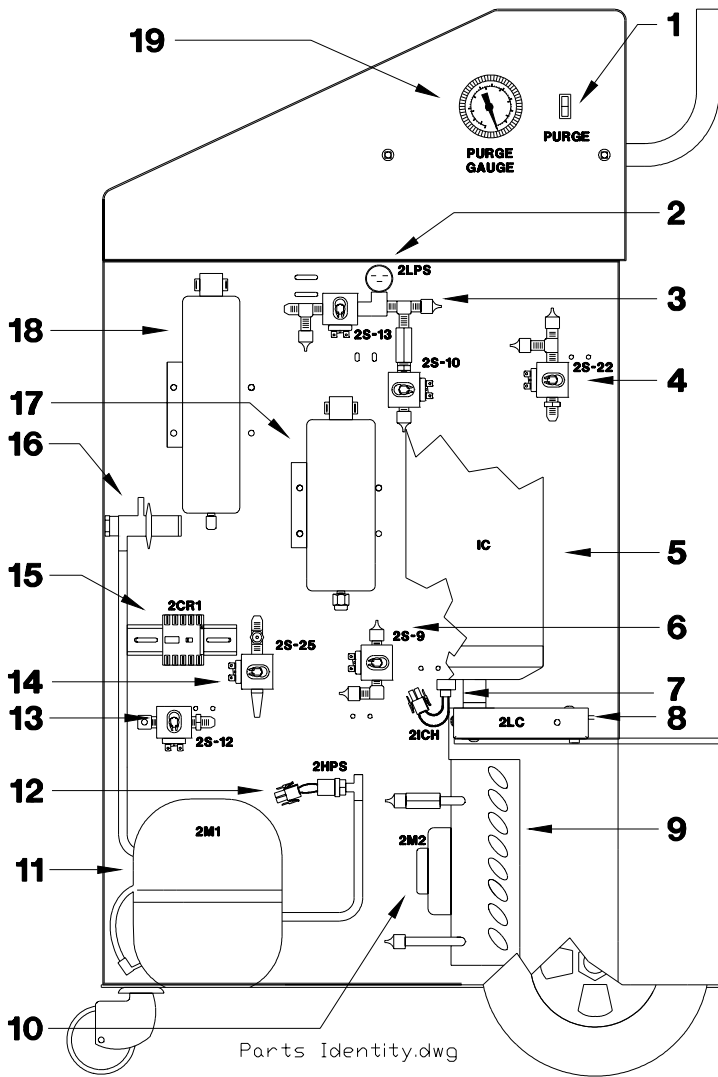

	PART NO.	DESCRIPTION
1	024-80035-00	Rocker Switch SPST (Momentary On)
2	360-81314-00	Low Pressure Switch 3 PSIG/15 InHg
3	360-81376-00	Manifold Assy R134a 120V
4	360-81384-00	Solenoid Assy 2S22 120V
5	360-81321-01	Charge Cylinder Assy 120V
6	360-81380-00	Solenoid Assy 2S9 120V
7	360-81337-01	Heater Assy 120V
8	031-80001-00	Load Cell 35Kg (with Support Assy)
9	360-81344-00	Cond Fan Assy 120V
10	360-80416-00	Fan Assy w/Pin Terminals 120V
11	360-81356-01	Compressor Assy 120V
12	360-81307-00	High Pressure Switch 261 PSIG
13	360-81382-00	Solenoid Assy 2S12 120V
14	360-81386-00	Solenoid Assy 2S25 120V
15	024-80037-00	Contactor ½ HP 120V 3 NO & 1NC
16	360-81390-00	Tube Assy Compressor Inlet R12
17	026-80069-00	Filter 3/8 Flare (Short)
18	026-80077-00	Filter 3/8 Flare (Long)
19	360-80260-00	Gauge Assy 0-500 PSIG

PARTS LIST - CONTROL PANEL - RHS2780E

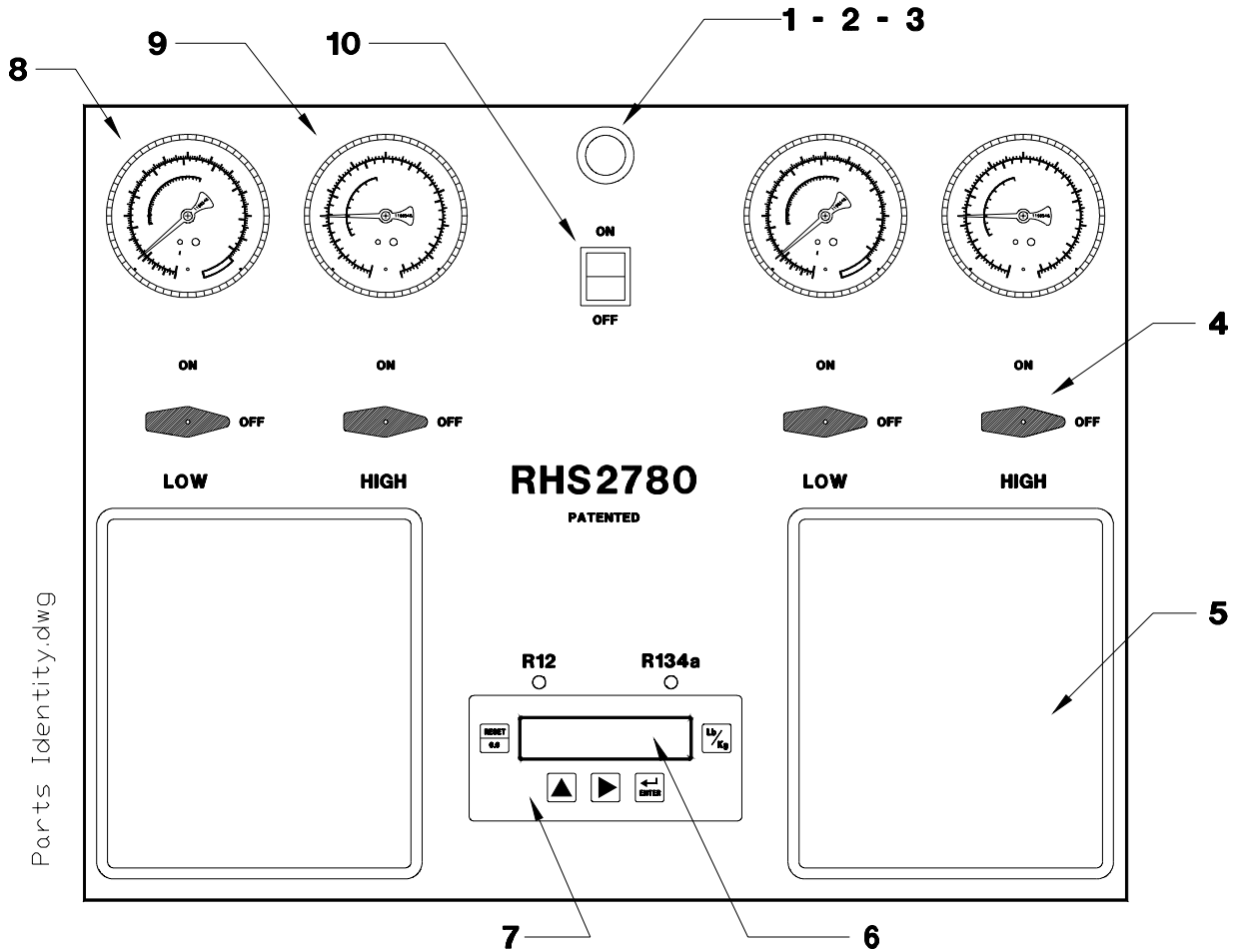

Parts Identity.dwg

	PART NO.	DESCRIPTION
1	025-80128-00	Lamp Holder w/Clear Bulb 120V
2	025-80131-00	Lens Assy Amber
3	025-80127-00	Clear Bulb Bayonet Base 120V
4	022-80027-00	In/Out Valve 2-Way Open CCW
5	060-80882-00	Plastic Tray (Black)
6	024-80067-01	Circuit Board (2780E/00) 120V
7	024-80059-00	Keypad Membrane
8	026-80065-03	Gauge 30 InHg - 120 PSIG 1/4 MFL
9	026-80071-03	Gauge 0"-500 PSIG 1/4 MFL
10	024-80040-00	Rocker Switch SPDT - Amber 125V

PARTS LIST - R12 SIDE

RHS2780V

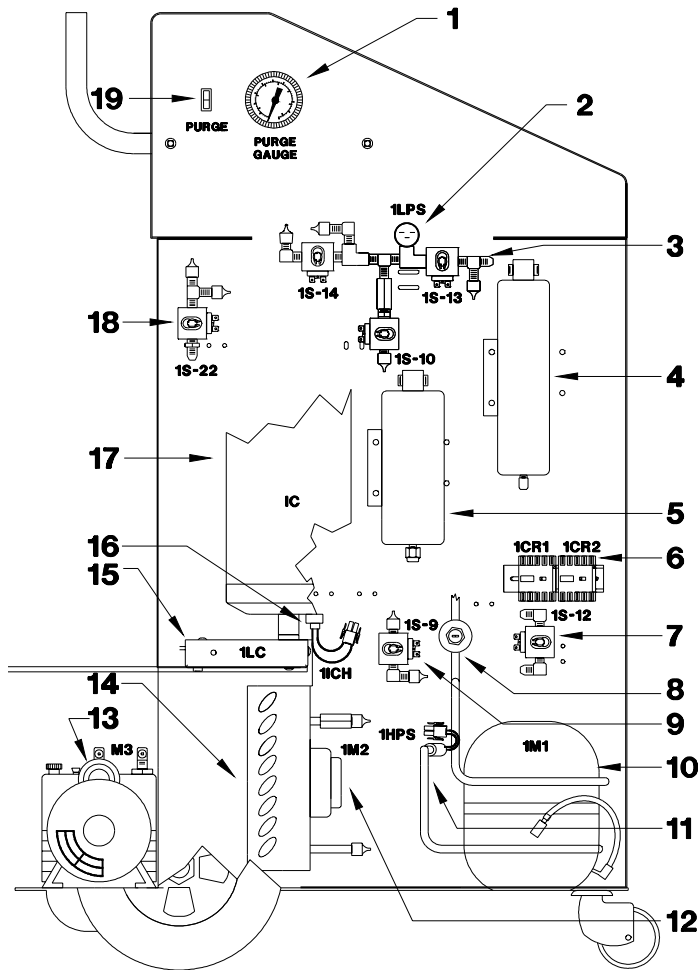

	PART NO.	DESCRIPTION
1	026-80071-02	Gauge 0-500 Psig
2	360-81314-00	Low Pressure Switch 3 Psig/15 InHg
3	360-81377-00	Manifold Assy R12 (2780V/00) 120V
4	026-80077-00	Filter (Long)
5	026-80069-00	Filter (Short)
6	024-80037-00	Contactor ½ HP 120V 3 NO & 1NC
7	360-81381-00	Solenoid Assy 1S12 120V
8	360-81389-00	Tube Assy Compressor Inlet R12
9	360-81379-00	Solenoid Assy 1S9 120V
10	360-81356-01	Compressor Assy 120V
11	360-81307-00	High Pressure Switch 261 Psig
12	360-80416-00	Fan Assy w/Pin Terminals 120V
13	026-80193-00	Vacuum Pump 3 CFM
14	360-81344-00	Cond Fan Assy 120V
15	031-80001-00	Load Cell 35Kg (with Support Assy)
16	360-81337-01	Heater Assy 110V
17	360-81321-01	Charging Cylinder Assy 120V
18	360-81383-00	Solenoid Assy 1S22 120V
19	024-80035-00	Rocker Switch SPST (Momentary On)

PARTS LIST - R134a SIDE

RHS2780V

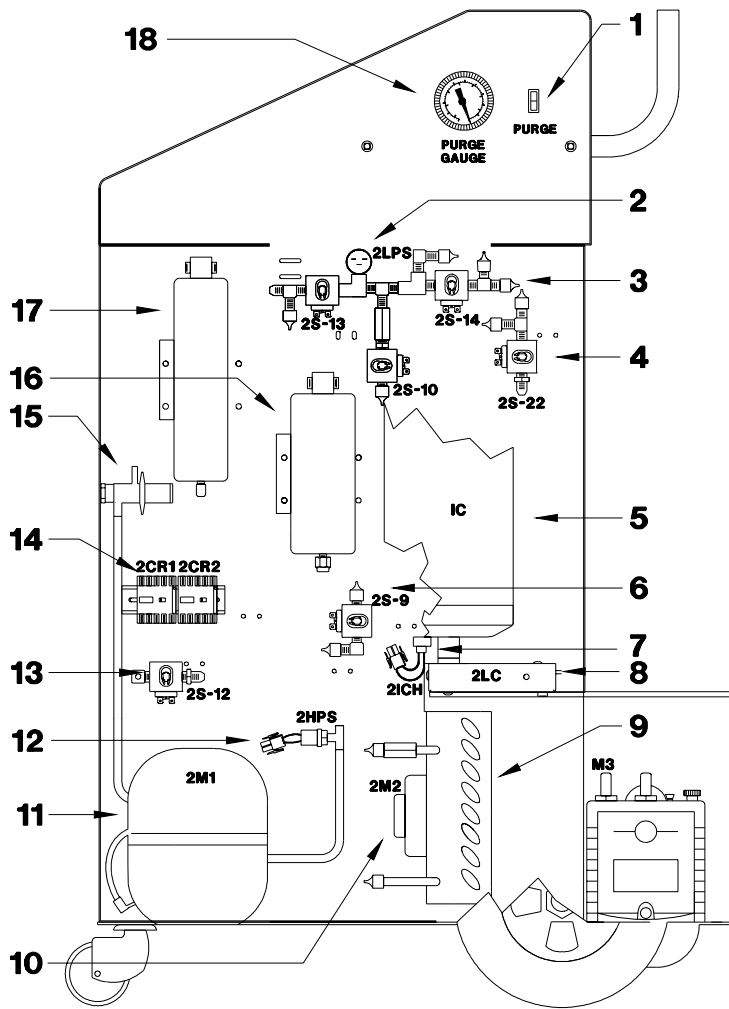

	PART NO.	DESCRIPTION
1	024-80035-00	Rocker Switch SPST (Momentary On)
2	360-81314-00	Low Pressure Switch 3 Psig/15 InHg
3	360-81378-00	Manifold Assy R134a (2780V/00) 120V
4	360-81384-00	Solenoid Assy 2S22 120V
5	360-81321-01	Charging Cylinder Assy 120V
6	360-81380-00	Solenoid Assy 2S9 120V
7	360-81337-01	Heater Assy 110V
8	031-80001-00	Load Cell 35Kg (with Support Assy)
9	360-81344-00	Cond Fan Assy 120V
10	360-80416-00	Fan Assy w/Pin Terminals 120V
11	360-81356-01	Compressor Assy 120V
12	360-81307-00	High Pressure Switch 261 Psig
13	360-81382-00	Solenoid Assy 1S12 120V
14	024-80037-00	Contactora ½ HP 120V 3 NO & 1NC
15	360-81390-00	Tube Assy Compressor Inlet R12
16	026-80069-00	Filter (Short)
17	026-80077-00	Filter (Long)
18	026-80071-02	Gauge 0-500 Psig

PARTS LIST - CONTROL PANEL - RHS2780V

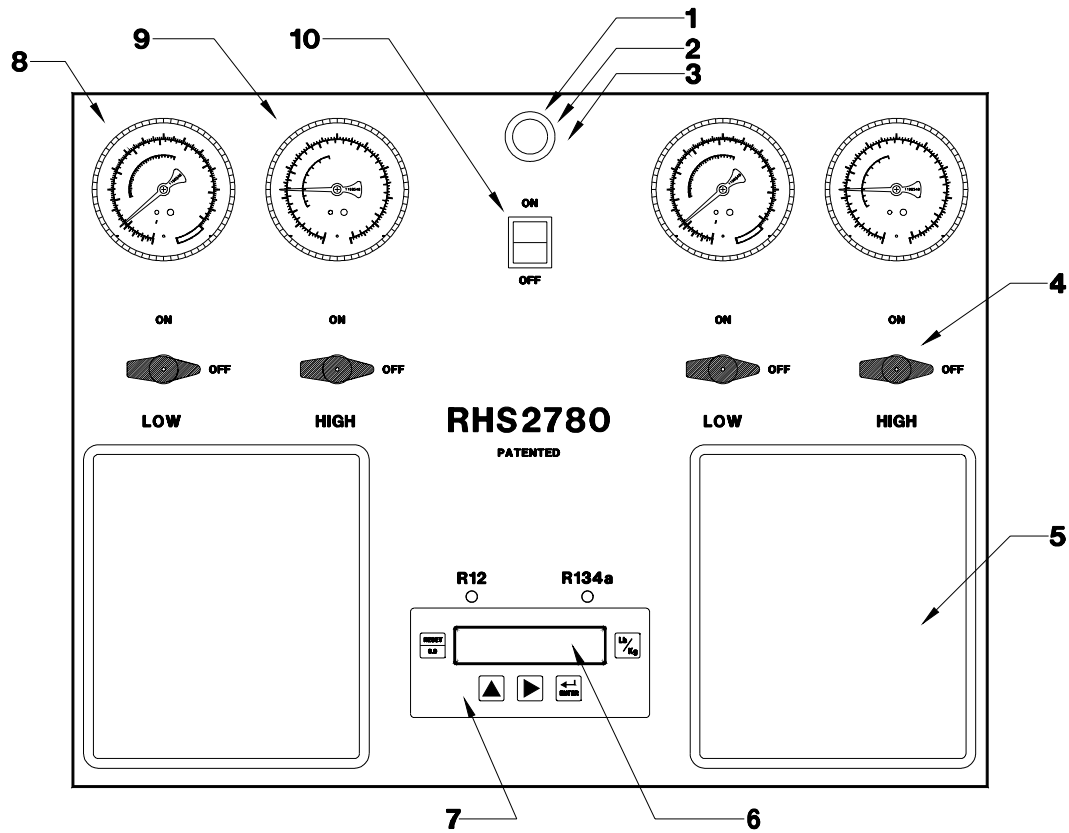

	PART NO.	DESCRIPTION
1	025-80128-00	Holder Lamp w/Clear Bulb 120V
2	025-80131-00	Lens Assy Amber
3	025-80127-00	Clear Bulb Bayonet Base 120V
4	022-80027-00	Ball Valve 2-Way Open
5	060-80882-00	Plastic Tray (Black)
6	024-80069-01	Circuit Board (2780V/00) 120V
7	024-80059-00	Keypad Membrane
8	026-80065-03	Gauge 30 InHg-120 Psig 1/4 MFL
9	026-80071-03	Gauge 0-500 Psig 1/4 MFL
10	024-80040-00	Rocker Switch SPDT - Amber 125V