

**OPERATION
&
MAINTENANCE
MANUAL**

750 & 751V

R12

TABLE OF CONTENTS

MODEL 750 & 751V

Before Using	Page 2
Safety Precautions	Page 3
Pre-Charging	Page 4
Recycle Mode Of Operation	Page 6
Hose Evacuation	Page 8
Charge Mode Of Operation	Page 10
Scheduled Maintenance	Page 12
Problems & Solutions	Page 14
Flow Diagram	Appendix
Circuit Diagram	Appendix

The **Model 750** has a 30 lb. DOT Cylinder mounted on the rear platform. Excess refrigerant can be charged from the Access Port of the 750 into this Cylinder for storage. An Overfill Protection (OFP) Device prevents overfilling the Cylinder. When the Cylinder is filled to capacity, the Cylinder Full Light will illuminate on the 750 Control Panel.

The **Model 751V** has a Vacuum Pump mounted on the Rear Platform. The Vacuum Pump is plugged into the Receptacle on the rear of the unit. The Vacuum Pump will be operational when the Power Switch is in the OFF Position. The Ready Light will be Off and the Auxiliary Light will be illuminated.

The following pages refer to "750" which in general also applies to "751V"

CONGRATULATIONS: You have purchased one of the finest R12 Recovery, Recycling, and Charging Machines available at any price.

Fill out and return the Warranty Card within 90 days to activate Warranty and Free Technical Support.

BEFORE USING THE 750

Check for any shipping damage. Place a claim with carrier if damage is discovered.

DO NOT USE A DAMAGED UNIT.

Complete and return the Warranty Card to activate technical support and warranty coverage

Warranty claims can not be honored without this warranty card on file.

The 750 should not be operated or serviced by any person who has not read all the contents of this manual. Failure to read and comply with these instructions or any one of the limitations noted herein can result in serious injury and/or property damage.

These general instructions deal with the normal operation and maintenance situations encountered with the 750. The instructions should not be interpreted to anticipate every possible contingency.

It is the responsibility of the owner/user to operate the 750 in accordance with all specifications and laws which may apply.

The following pages contain rules for safe operation of the 750. Taking precedence over any specified rule listed herein, however, is the most important rule of all:

"USE COMMON SENSE"

A few minutes spent reading these instructions can make an operator aware of dangerous practices to avoid and precautions to take for his own safety and the safety of others.

A regular schedule of inspection of the 750 should be established and records maintained with special attention given to Hoses, Oil Levels, Moisture Indicator, and Filters.

SAFETY PRECAUTIONS

- Recover, Recycle, and Charge R12 refrigerant only
- Wear safety glasses and protective gloves. Refrigerant has a very low boiling point and can cause frostbite.
- Follow the 750 operating procedures sequentially to avoid prematurely disconnecting hoses or opening valves which may release refrigerant to the atmosphere.
- Do not expose the 750 to moisture or operate in wet areas
- Use the 750 in locations with mechanical ventilation that provides at least four air changes per hour.
- Hoses used with the 750 must have shutoff devices within 12 inches of the connection point to the system being serviced to minimize the introduction of non-condensable gases into the recycling unit and the release of refrigerant when being disconnected.
- Disconnect power before performing any maintenance or service on the 750
- Avoid using an extension cord with the 750. If necessary, use a good condition, UL listed, 3-wire grounded, #14 AWG extension cord of the shortest possible length.
- Connect the 750 to a properly protected, grounded receptacle Do not over load the circuit.
- Do not allow the 750 to remain unattended in the Charge Mode with power On. The Internal Cylinder Heater will be energized creating a high pressure condition.

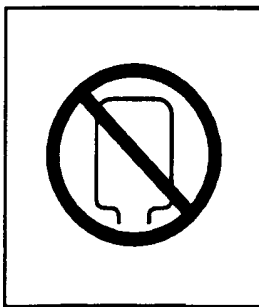

NEVER TURN THE CYLINDER UP-SIDE-DOWN.

DO NOT CONNECT THE 750 TO THE LIQUID SIDE OF ANY A/C SYSTEM WITH A CAPACITY GREATER THAN 4 LBS.

REFRIGERANT IN A/C SYSTEMS HAVING LARGER CAPACITIES MUST BE RECOVERED FROM THE VAPOR SIDE ONLY.

NEVER CONNECT THE 750 TO THE LIQUID PORT OF A CYLINDER OF REFRIGERANT TO FILL THE 750 INTERNAL CYLINDER.

FAILURE TO FOLLOW THE ABOVE MAY CAUSE THE 750 COMPRESSOR TO FAIL AND VOID THE WARRANTY.

PRE-CHARGING THE 750

A/C Systems requiring service often do not have a full charge of refrigerant. To avoid unnecessary repositioning of hoses it is recommended that the 750 be pre-charged until about 3 pounds of liquid refrigerant can be seen in the Internal Cylinder Sight Glass. The Sight Glass is visible through a slotted opening on the right side of the 750.

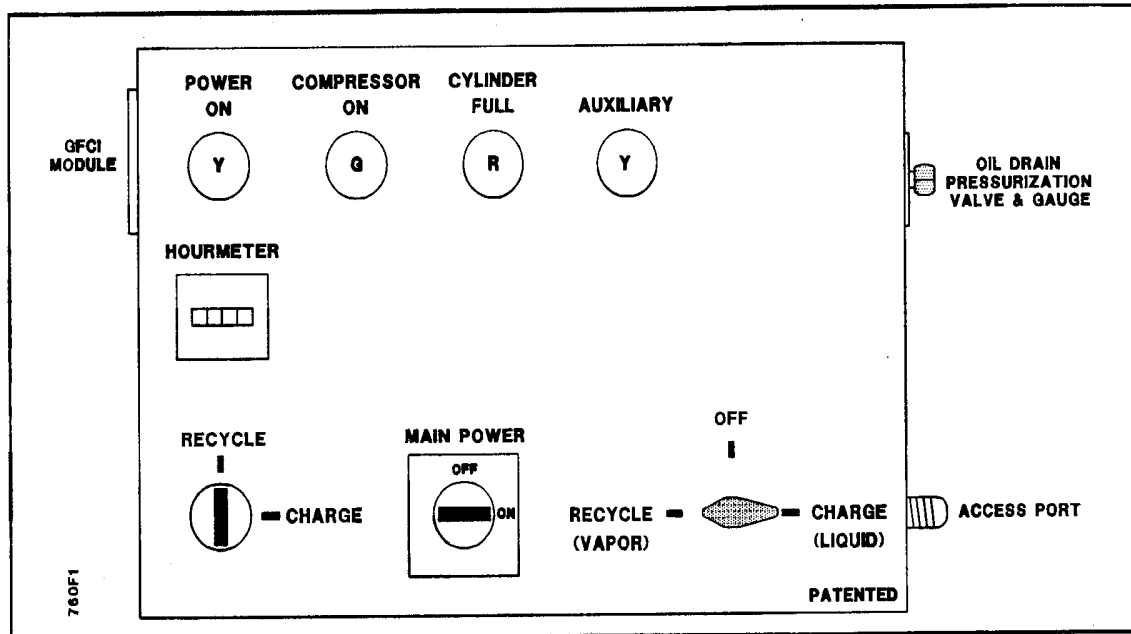

Figure 1 Pre-charging

To Pre-charge the 750, refer to Figure 1 and follow these steps:

1. Turn Main Power Switch to OFF.
2. Connect VAPOR PORT of a cylinder of clean refrigerant to the 750 Access Port using the Yellow Service Hose.

Observe that the embossed marking on the cylinder knob says VAPOR or GAS. Do not rely on color coding of valve knobs.



DO NOT TURN THE CYLINDER UP-SIDE-DOWN.

INTRODUCTION OF LIQUID INTO THE 750 MAY DAMAGE COMPRESSOR AND VOID THE WARRANTY.

3. Open Service Hose Valve and the refrigerant cylinder VAPOR valve.
4. Turn the Flow Control Valve to RECYCLE.

5. Set Mode Selector to RECYCLE.
6. Turn Main Power Switch to ON.

The Compressor-On Light will illuminate and the 750 will recover and recycle refrigerant into the Internal Cylinder. Observe the liquid refrigerant level rise in the Internal Cylinder Sight Glass and when at approximately 3 lbs. close the Vapor Valve on the refrigerant cylinder.

HINT: *GENTLE* heating of the cylinder of clean refrigerant by immersion in warm water or application of a heating blanket will speed the recovery process.

Allow the 750 to continue running until the Compressor-On Light goes off. This will evacuate the Service Hose.

7. When the Compressor-On Light goes off, turn the Flow Control Valve to OFF and turn the Main Power Switch to OFF.
8. Close Service Hose Valve

NOTE: As refrigerant is processed by the 750, temperature variations can cause vapor to change to liquid which may temporarily settle in various internal components.

If a known amount of refrigerant has been introduced into the 750 it may not all be seen in the Internal Charging Cylinder Sight Glass.

This is normal and nothing to be concerned about.

The refrigerant has not been lost.

RECYCLE MODE

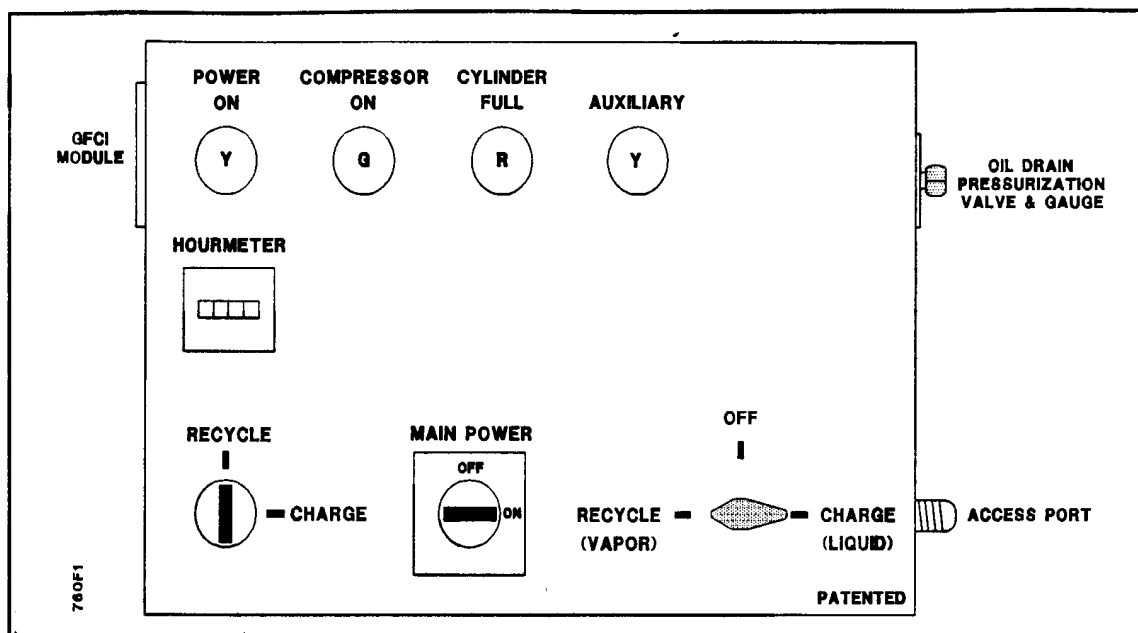

Figure 2 Recycle

To Recycle, refer to Figure 2 and follow these steps:

1. Connect the Service Hose from the Access Port of the 750 to the center port of a Gauge Manifold. The Service Hose Valve should be on the end connected to the 750.
2. Attach High and Low Gauge Manifold Hoses to the A/C system per the vehicle manufacturer's instructions.
3. Open Gauge Manifold Valves.
4. Open Service Hose Valve.
5. Turn Flow Control Valve to RECYCLE.
6. Set Mode Selector to RECYCLE.
7. Turn Main Power Switch to ON.

The Compressor-On Light will illuminate. The Compressor and Condenser Fan will be heard operating as refrigerant is recovered from the A/C System.

The 750 will recover refrigerant from the A/C system until a vacuum is sensed. Compressor will turn off and the Compressor-On Light will turn off.

● DO NOT TURN THE 750 OFF OR DISCONNECT HOSES ●

A small quantity of Liquid refrigerant will probably remain in the A/C system. This liquid

will vaporize (boil up) and increase the pressure in the system as the components again warm to ambient temperature. This can be detected by observing an increasing pressure reading on the Low Side of the Gauge Manifold.

If pressure increases to a preset level, the 750 will again start to recover refrigerant. Compressor will turn on and the Compressor-On Light will illuminate.

Allow this sequence to repeat until the Compressor-On Light remains off continuously for at least 2 minutes.

NOTE: Several audible changes may be heard during the recovery and recycling process.

The non-condensable gas venting circuit will cycle periodically.

Refrigerant flow through check valves causes a "sizzle-type" sound.

These changing "noises" are normal and nothing to be concerned about.

8. Close Service Hose Valve and Gauge Manifold Valves.
9. Turn Flow Control Valve to OFF.
10. Turn Main Power Switch to OFF.
11. **SLOWLY** turn Oil Drain Pressurization Valve (Located below the Pressure Gauge next to the Access Port) in a clockwise direction until the pressure decreases approximately 5 PSIG. This will create a positive pressure in the Oil Drain Reservoir to enable any oil to drain during the next step.
12. Slowly open Oil Drain Valve (Located at the lower left side of the 750 as viewed from the back) to drain any oil which may have been removed from the A/C system. Close the valve as soon as the oil, if any, has drained.

Unless the A/C system had been overfilled, the 750 will not remove enough oil to make replenishment necessary.

Hoses can now be disconnected and the A/C system serviced.

CYLINDER FULL LIGHT The Cylinder Full Light will illuminate if the Internal Cylinder fills to capacity. The Internal Cylinder will have to be charged into a DOT storage cylinder before continuing the Recycle procedure.

HOSE EVACUATION

It's important that Air not be introduced into the A/C system during a Charging procedure. To avoid this situation, all hoses and the Gauge Manifold must be evacuated.

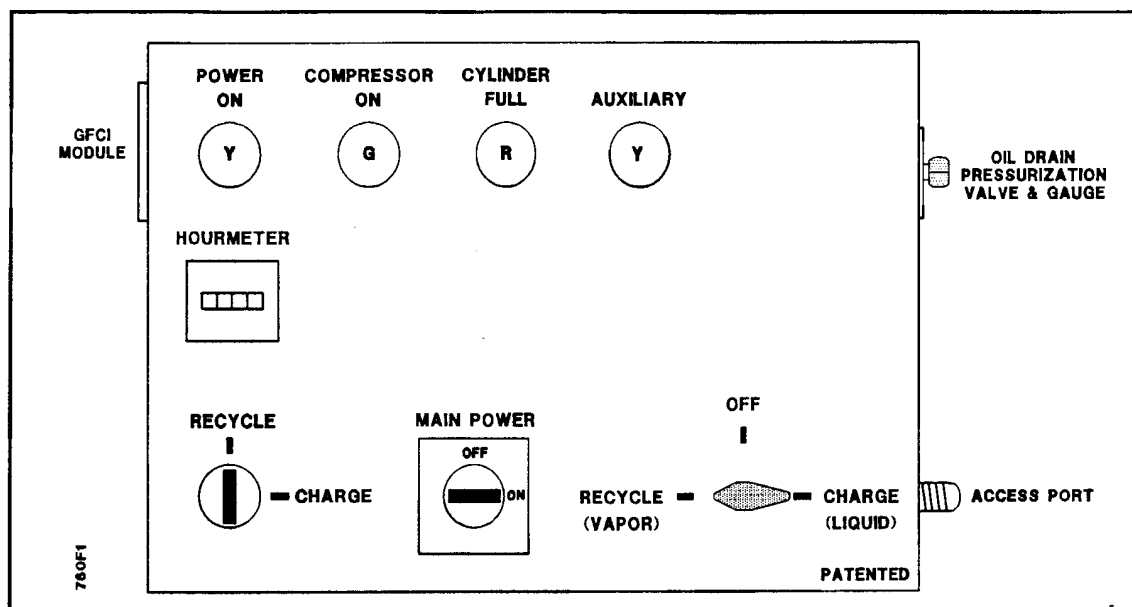

Figure 3 Hose Evacuation

To Evacuate Hoses and Gauge Manifold, refer to Figure 3 and follow these steps:

1. Connect Red and Blue Hoses to the high and low ports of the Gauge Manifold.
2. Connect Service Hose as follows:

Connect end without a Shut Off Valve to center port of the Gauge Manifold.

Connect end with a Shut Off Valve to Access Port of the 750.

NOTE: If the Service Hose is not connected as described above, the 750 will not charge.

A Valve Core Depressor must be in the end of the hose connected to the 750.

3. Close Red and Blue Hose Valves.
4. Open High and Low Gauge Manifold Valves.
5. Open Service Hose Valve.
6. Turn Flow Control Valve to RECYCLE.
7. Set Mode Selector Switch to RECYCLE.

8. Turn Main Power to ON.

The 750 will remove any Air or refrigerant remaining in all hoses and the Gauge Manifold.

9. When the Compressor-On Light goes off, turn the Main Power Switch OFF.

10. Turn Flow Control Valve to OFF.

11. Close Service Hose Valve and the Gauge Manifold Valves.

All Air has now been removed from the Hoses and Gauge Manifold and the Charge procedure can be performed.

CHARGE MODE

If the A/C repair caused the necessity of replacing a major component such as the Compressor or Accumulator, it is recommended that a deep vacuum be pulled on the system to remove any moisture before charging.

The Hoses and Gauge Manifold should be evacuated as described in the previous section. will prevent introducing air into the A/C System during the Charging Procedure.

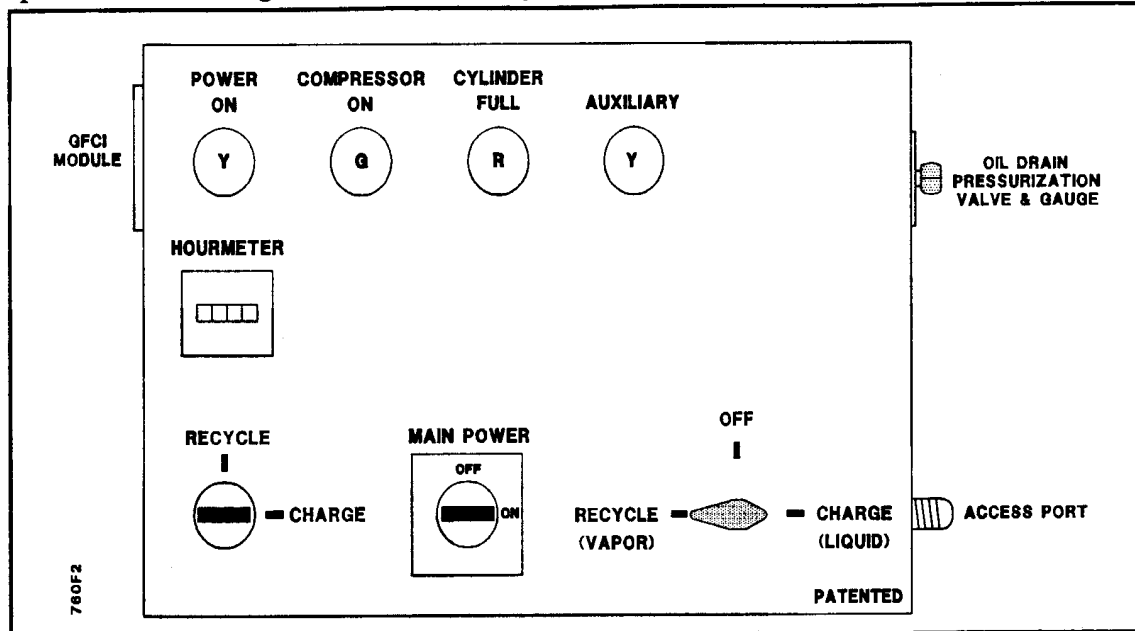

Figure 4 Charging

To Charge, refer to Figure 4 and follow these steps:

1. Connect Service Hose from the center port of the Gauge Manifold to the 750 Access Port.
2. Attach the Gauge Manifold High Side Hose to the A/C system per the vehicle manufacturer's instructions.
3. Set Mode Switch to CHARGE.
4. Turn Flow Control Valve to CHARGE.
4. Open valve on Service Hose.
5. Open High Side Hose Valve.
6. Determine the refrigerant capacity of the A/C system to be charged and set the Sliding Indicator on the 750 Internal Cylinder Sight Glass.

The A/C System Refrigerant Capacity is usually printed on a tag located on the accumulator or under the hood of the vehicle. Convert this quantity to tenths of a pound or pounds and ounces, if necessary, for setting the 750 charge indicator.

NOTE: The Sight Glass on the Internal Cylinder is marked in "tenths of a pound".

Do not confuse the graduation marks as being in grams.

The following will determine where to set the indicator prior to starting the charge mode:

$$(\text{760 Liquid Level}) - (\text{A/C System Capacity}) = \text{Indicator Setting}$$

EXAMPLE: The level of liquid visible in the 750 Internal Cylinder Sight Glass is 7.4 lbs. and the A/C system capacity is 3.2 lbs. The following calculation results...

$$(7.4) - (3.2) = 4.2$$

Therefore, the sliding indicator should be set at 4.2 lbs. in this example. When the liquid level lowers to the 4.2 lb. mark, a charge of 3.2 lbs. will have been delivered

7. Turn Main Power Switch to ON. **DO NOT START THE VEHICLE'S ENGINE**
8. **SLOWLY** open Gauge Manifold **HIGH** Side Valve

Refrigerant will flow into the high side of the A/C System. Closely monitor the liquid level as it lowers in the Internal Cylinder Sight Glass.

NOTE: Gauge on side of the 750 Top Box indicates pressure in the Charging Cylinder. To accelerate charging, it may be advisable to wait for the Internal Cylinder Heater to increase the pressure before beginning the charging process.

9. Turn Flow Control Valve to OFF as soon as the level drops to the sliding indicator.
10. Turn Main Power Switch to OFF.
10. Disconnect Gauge Manifold High Hose from the A/C System.
11. Evacuate the Hoses and Gauge Manifold as described in the previous section. Close all valves before disconnecting hoses.

NOTE: Some vehicle manufacturers may specify connecting only to the Low Side of the A/C System. Always follow their procedures. The above instructions would have to be modified accordingly.

SCHEDULED MAINTENANCE

COMPRESSOR OIL

Check the oil level in the Compressor *DAILY* before using the 750. The Oil Level Sight Tube is visible through a cut-out in the left side of the black Compressor Cover at the bottom of the machine.

The oil level should be visible in the cut-out and within the range indicated in the illustration.

If oil is not visible or is above the middle of the cut-out call the Warranty Repair Number:

800-468-2321

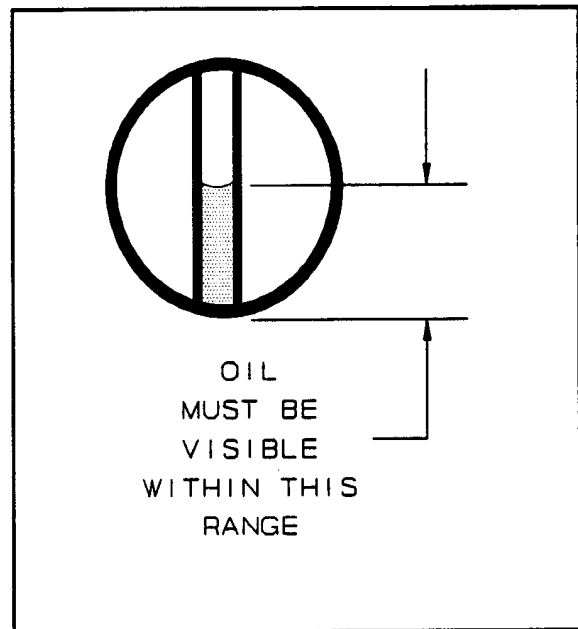

The oil in the Compressor should be **changed yearly** (or after approximately 50 hours use in a high volume shop). The best time to schedule this procedure is at the end of the peak season, just prior to "storing" the 750.

Contact the manufacturer at 800-468-2321 for a special Oil Change Kit and Instructions.

An oil Drain Fitting is provided on the rear of the unit for draining the Compressor oil

VACUUM PUMP OIL (Model 751V)

Vacuum Pump Oil should be changed at least yearly. Consistently deeper vacuums will be achieved if the Oil is changed every 90 days.

It's recommended that Vacuum Pump Oil always be changed at the end of the peak season prior to "storing" the 750.

Contact the manufacturer at 800-468-2321 for Oil Change Kit and Instructions

CONDENSER

Periodically clean the Condenser to maintain high efficiency performance of the 750. Disconnect power and remove the Compressor Compartment Cover and blow compressed air through the cooling fins of the Condenser to remove any debris. It may be necessary to use a soft brush if the fins are excessively dirty.

Do not bend the fins on the Condenser coil. Air flow will be restricted and cause damage to the 750. Replace the Compressor Compartment Cover before applying power to the 750.

FILTER-DRIER & ACID FILTER

Replace the Filter-Drier and Acid Filter after 75 Hours of operation, or when Moisture Indicator stays "Bright Pink" after 20 Hours of operation.

To replace the Filter-Drier and Acid Filter:

- 1 Disconnect 750 from Power.
2. Remove the Main Cabinet Cover
3. Locate the Filter-Drier mounted on the back wall inside Main Cabinet.
 - 3.1 Disconnect Flare Adaptor Fittings at top and bottom of Filter-Drier.
 - 3.2 Remove mounting nuts and remove Filter-Drier.

Remove the black insulation and install on new Filter-Drier

Install new Filter-Drier using the nuts removed earlier.

Connect Flare Adaptor Fittings to top and bottom of Filter-Drier. Tighten 1/5 turn past finger-tight.

4. Locate the Acid Filter mounted above the two solenoids.

Disconnect top flare fitting and rotate the Acid Filter out of the lower union.

Install new Acid Filter reversing the above steps. Flow direction arrow should point down.

5. Check for leaks and repair as required.
6. Replace Main Cabinet Cover.

PROBLEMS & SOLUTIONS

On rare occasion the 750 may seem to be performing differently or not at all. Experience has shown that varying operating conditions can affect the performance characteristics of the 750. The temperature of the vehicle A/C System will affect how the 750 performs.

Following are typical problems with explanations of the possible cause and solution

PROBLEM: My 750 worked fine all last Summer. I got it out today for the first service job this Spring and it is very slow in evacuating the system.

SOLUTION: Today's Spring temperature may be much lower than the average temperatures during the summer months. Maybe the vehicle was brought in from outside where the temperature is very low.

The refrigerant in the vehicle will not be under as high a pressure at lower temperatures and the 750 will take longer to draw a vacuum. More cycles may be required to completely recover the refrigerant.

PROBLEM: I put 5 lbs. of refrigerant into the 750 using the Recycle Mode. When I checked the sight glass on the Internal Cylinder, there was less than 5 lbs. I lost Refrigerant. The unit must leak.

SOLUTION: Due to temperature changes, some refrigerant may condense into liquid form and stay in tubes and other components in the circuit preceding the Internal Cylinder. This is normal and will explain why all refrigerant is not visible in the sight glass.

PROBLEM: When I try to fill the Internal Cylinder from an auxiliary cylinder of clean refrigerant, the 750 is really slow or shuts down.

SOLUTION: The auxiliary cylinder will cool due to the vaporization of refrigerant causes the pressure to decrease.

Place the cylinder in a bucket of warm water. A heat belt can also be used. This will aid in increasing the speed of recycling by the 750.

PROBLEM: The Oil Drain Valve is warm/hot to the touch (751V Model Only).

SOLUTION: The thermostatically controlled Oil Heater is mounted in a reservoir next to the Oil Drain Valve. The temperature setting is approximately 110 degrees. This can seem quite warm, but is nothing to be concerned about.

PROBLEM: I turned a 30 lb. cylinder of new refrigerant up-side-down to pre-charge the Internal Cylinder with liquid. The Internal Cylinder didn't fill and now the 750 won't recover from an A/C system.

SOLUTION: The 750 has been overloaded with liquid refrigerant (See Safety Precaution Section at the beginning of this manual).

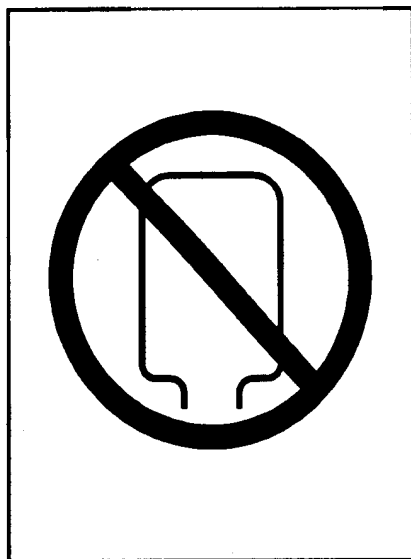

IF A CYLINDER IS TURNED UP-SIDE-DOWN, THE 750 WILL OVERFILL WITH LIQUID REFRIGERANT. THIS OVER FILLS THE SUCTION ACCUMULATOR WITH LIQUID.

FROST ON THE OIL DRAIN ON THE REAR OF THE 750 IS A GOOD INDICATION OF THIS OCCURRENCE.

THIS SYMPTOM IS CAUSE FOR CONCERN AS LIQUID REFRIGERANT WILL BE FORCED INTO THE COMPRESSOR.

THIS CAN DESTROY THE COMPRESSOR AND WILL VOID THE WARRANTY.

The safest method to remove the excess liquid which has collected in the Suction Accumulator is to drain it from the Oil Drain on the back of the 750 as follows:

Draw a deep vacuum (25 to 29 In. Hg.) on an empty cylinder and connect it to the Oil Drain. Open the cylinder valve and the Oil Drain valve.

Close the valves and disconnect the cylinder after the liquid has been emptied into the cylinder. This refrigerant can now be recycled by the 750 following normal recycling procedures.

PROBLEM: My Compressor On Light went out with a lot of pressure still left in the A/C system I'm recovering from.

SOLUTION: Large amounts of Non-Condensable Gases may cause the Compressor to momentarily shut off before the inlet pressure is in a vacuum. This is a normal part of the venting process as refrigerant flow into the Internal Cylinder is stopped during the venting of Non-Condensable Gases.

The Compressor will re-start a few moments after this venting stops.

If the above suggested solutions do not solve the problem, call 800-468-2321 and one of our technicians will help diagnose the cause. Please have the Serial Number and hour meter reading available for reference.

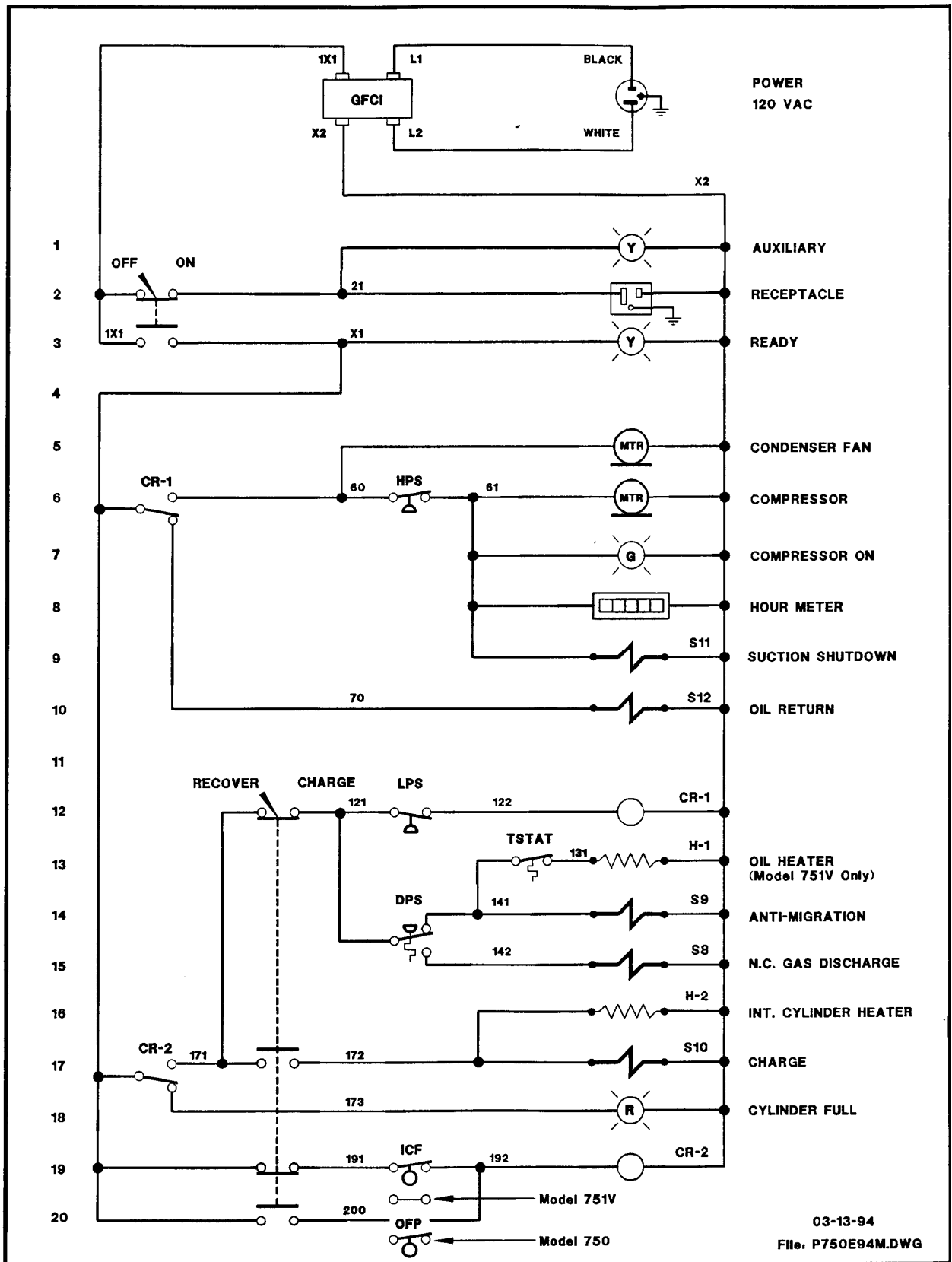

SCHEMATIC - MODEL 750 & 751V

03-13-94
File: P750E94M.DWG