

Operation & Maintenance Manual

TX200-UNDP

RTI TECHNOLOGIES, INC.

4075 East Market Street
York, Pennsylvania, USA 17402
Telephone: 717-840-0678 (Ext. 259)
Fax: 717-755-8304
Web-site: www.rtitech.com

Manual P/N 035-80916-00

● TABLE OF CONTENTS ●

TX200

Before Using The TX200	Page 2
Safety Precautions	Page 3
Recover Mode	Page 4
Procedure for Fast Recovery	Page 7
Purging Air From The ERC Cylinder	Page 8
Procedure for Clearing TX200 between Refrigerants	Page 9
Compressor Maintenance	Page 10
Condenser Maintenance	Page 11
EDF Filter Replacement	Page 11
SPR Adjustment	Page 12
Problems & Solutions	Page 13
Accessory Parts List	Page 14
Flow Diagram	Page 15
Schematic	Page 16

BEFORE USING THE TX200

Check for any shipping damage. Place a claim with carrier if damage is discovered.

DO NOT USE A DAMAGED UNIT.

The TX200 should not be operated or serviced by any person who has not read all the contents of this manual. Failure to read and comply with these instructions or any one of the limitations noted herein can result in serious injury and/or property damage.

These general instructions deal with the normal operation and maintenance situations encountered with the TX200. The instructions should not be interpreted to anticipate every possible contingency.

It is the responsibility of the owner/user to operate the TX200 in accordance with all specifications and laws which may apply.

The following pages contain rules for safe operation of the TX200. Taking precedence over any specified rule listed herein, however, is the most important rule of all:

"USE COMMON SENSE"

A few minutes spent reading these instructions can make an operator aware of dangerous practices to avoid and precautions to take for his own safety and the safety of others.

A regular schedule of inspection of the TX200 should be established and records maintained with special attention given to Hoses and Compressor Oil Level.

SAFETY PRECAUTIONS

- Recover R12, R22, or R502 Refrigerant only.
- Wear safety glasses and protective gloves. Refrigerant has a very low boiling point and can cause frostbite.
- Follow the TX200 operating procedures sequentially to avoid prematurely disconnecting hoses or opening valves which may release refrigerant to the atmosphere.
- Do not expose the TX200 to moisture or operate in wet areas.
- Use the TX200 in locations with mechanical ventilation that provides at least four air changes per hour.
- Hoses used with the TX200 must have shutoff devices within 12 inches of the connection point to the system being serviced to minimize the release of refrigerant when being disconnected.
- Disconnect power before performing any maintenance or service on the TX200.
- Avoid using an extension cord with the TX200. If necessary, use a good condition, 3-wire grounded, 2.5 mm² extension cord of the shortest possible length.
- Connect the TX200 to a properly protected, grounded receptacle. Do not over load the circuit.
- Unplug Power Cord while connecting the OFP (Overfill Protection) Device to avoid bodily injury due to electrical shock. Do not force plug into OFP Device. Look at pins in plug and align them with sockets on OFP Device.
- **DO NOT CONNECT THE TX200 DIRECTLY TO THE LIQUID SIDE OF ANY A/C SYSTEM. ALWAYS CONNECT A CYLINDER BETWEEN THE A/C SYSTEM AND THE TX200. FAILURE TO DO SO MAY CAUSE THE TX200 COMPRESSOR TO FAIL.**

RECOVERY MODE

Figure 1 shows the recommended connection of the TX200 to an A/C System.

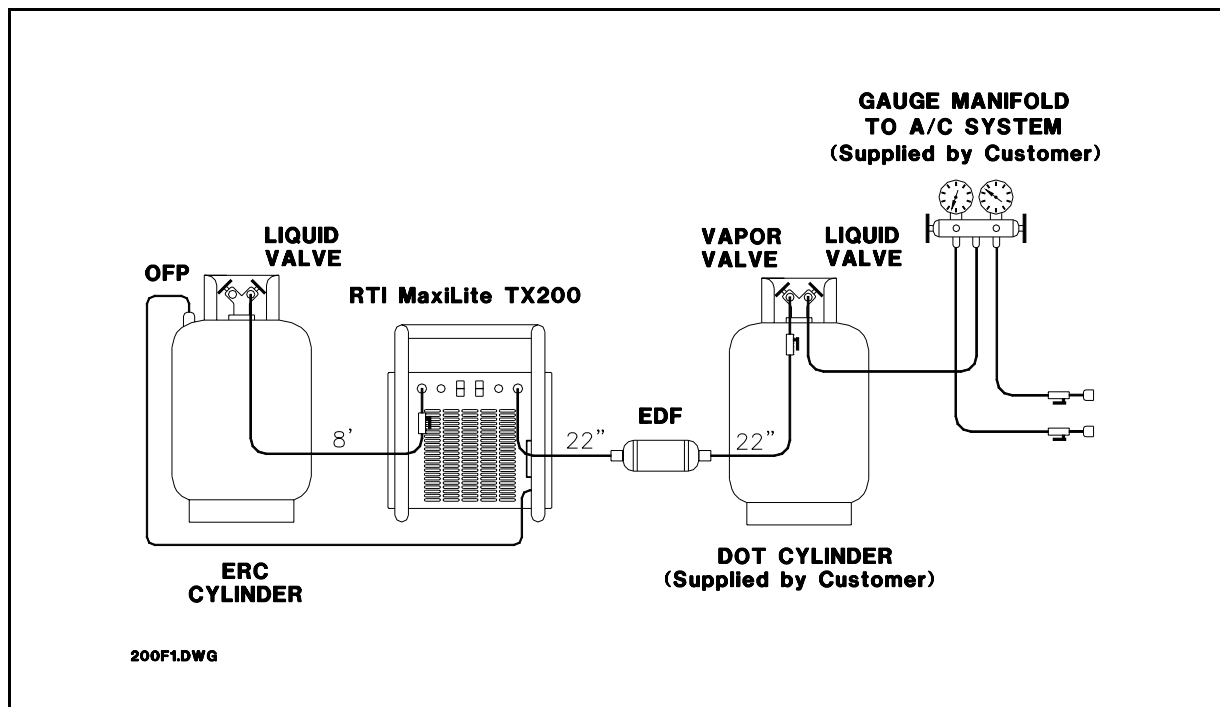

Figure 1 TX200 Connection For Recovery

CAUTION...

The hose from the A/C System must be connected to the **LIQUID VALVE** of the DOT Cylinder. The Hose from the DOT Cylinder to the External Disposable Filter (EDF) must be connected to the **VAPOR VALVE** of the DOT Cylinder. This prevents introduction of large quantities of liquid refrigerant, oil and acid into the TX200 which could damage the Compressor.

Do not depend on the colors of the Valve Knobs to indicate Liquid or Vapor. Always check the embossed printing on the knobs.

The ERC Cylinder must have an Overfill Protection (OFP) Device.

Disconnect Power Cord from power source while connecting the OFP (Overfill Protection) Device to avoid bodily injury due to electrical shock.

Connect Yellow Cable from TX200 to OFP Device on ERC Cylinder.

Do not force plug into OFP Device. Look at pins in plug and align them with sockets on OFP Device.

Connect TX200 Power Cord to a properly protected, grounded receptacle. Avoid using an extension cord. If necessary, use a good condition, 3-wire grounded, 2.5 mm² extension cord of the shortest possible length.

The TX200 is now ready to recover refrigerant.

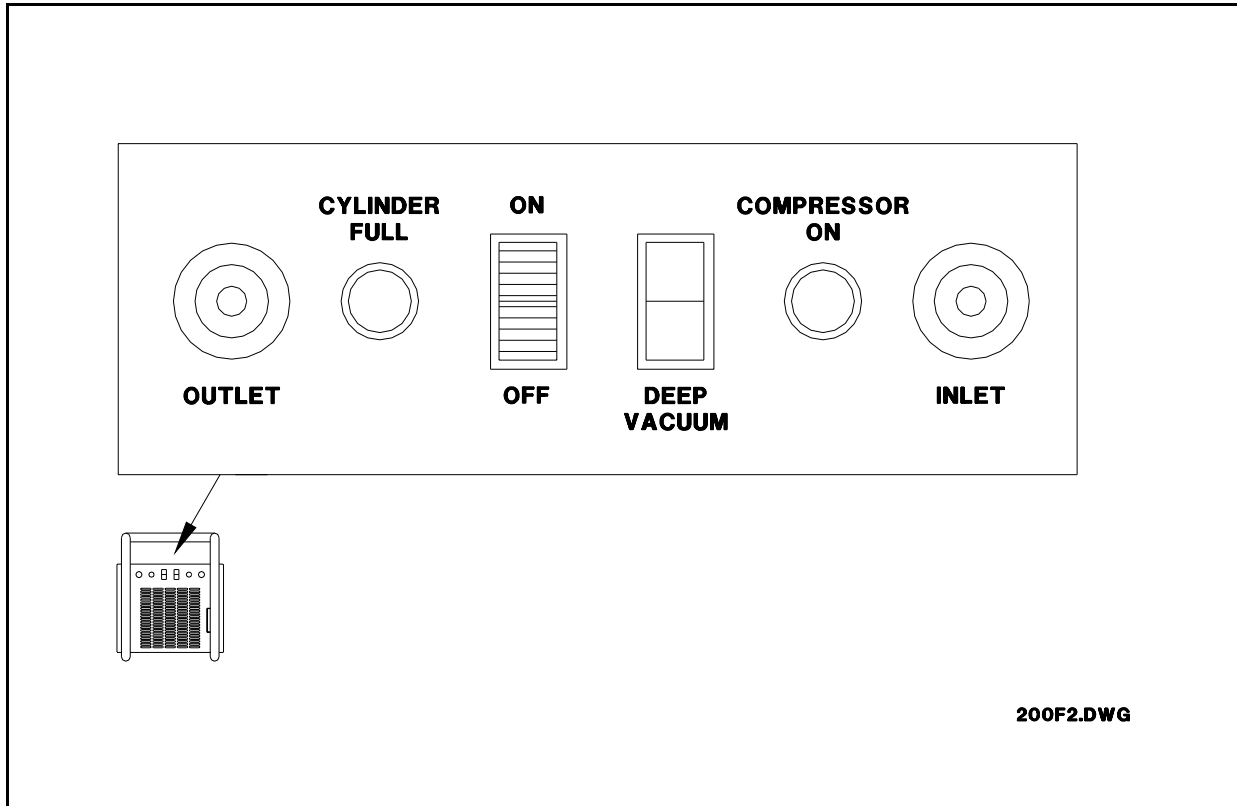

Figure 2 TX200 Control Panel

Press the top of the ON/OFF Switch. The switch will illuminate to indicate that power is on.

The COMPRESSOR ON Light will illuminate and the TX200 will begin recovering refrigerant.

The CYLINDER FULL Light will illuminate if the ERC Cylinder fills to capacity.

The TX200 will recover refrigerant until a vacuum is sensed. The Compressor will turn off and the Compressor-On Light will turn off.

● DO NOT TURN THE TX200 OFF OR DISCONNECT HOSES ●

A small quantity of Liquid refrigerant will probably remain in the A/C System. This liquid will vaporize (boil up) and increase pressure in the system as components again warm to ambient temperature.

If pressure increases to a preset level, the TX200 will again start to recover refrigerant. The Compressor will turn on and the Compressor-On Light will illuminate.

Allow this sequence to repeat until the Compressor-On Light remains off continuously for at least 2 minutes.

The DEEP VACUUM Switch can be pressed to draw a deeper vacuum if so desired.

Push bottom of Main Power Switch to turn TX200 OFF.

WARNING... DO NOT RECOVER FROM THE LIQUID SIDE OF AN A/C SYSTEM WITH A CAPACITY OF MORE THAN 20 LBS. UNLESS THE DOT CYLINDER ON THE INLET SIDE OF THE UNIT IS MONITORED FOR TOTAL WEIGHT.

REFER TO THE LIQUID CAPACITY OF THE CYLINDER AND DO NOT FILL BEYOND 80% OF THAT RATING.

USE A SCALE TO MONITOR THE WEIGHT.

Procedure for Fast Recovery

The goal of any technician is to recover all the refrigerant from an A/C system in as short a time as possible. This refrigerant will typically be in both liquid and vapor states. The TX200 must never be connected directly to a source of liquid refrigerant, as this may damage the unit. The following shows Cylinder 1 connected between the A/C system and the TX200. Scale 3 should be used to prevent overfilling Cylinder 1. The Liquid in the A/C system will be rapidly drawn into Cylinder 1 as the TX200 recovers vapor only and stores it in Cylinder 4. The liquid can be observed in Sight Glass 2 connected in-line.

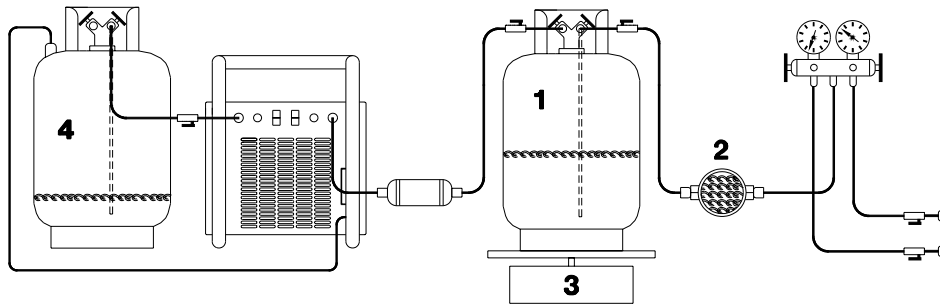

When all the liquid is removed, Cylinder 1 should be removed and the TX200 connected directly as shown in the next illustration. The TX200 will then rapidly draw all the remaining vapor refrigerant from the A/C system.

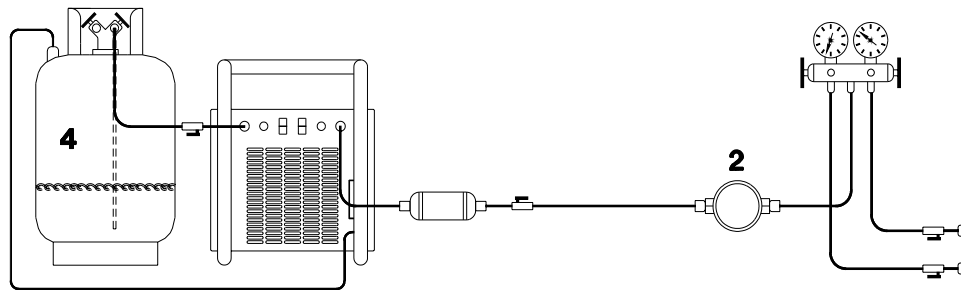

Once the A/C system has been emptied, the TX200 can be reconnected to Cylinder 1 and the remaining refrigerant recovered (this can be done while the technician is servicing the A/C system).

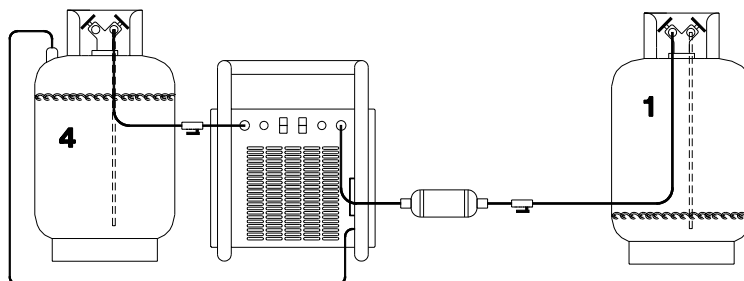

e: 200 WITH INLET SIGHT GLASS.DWG

PURGING AIR FROM THE ERC CYLINDER

Refrigerant recovered into the ERC Cylinder may also contain Air. This Air will increase the pressure in the ERC Cylinder and slow recovery. Large quantities of Air may even cause the TX200 to stop recovering due to a High-Pressure-Shutdown.

Check the pressure in the ERC Cylinder to determine the need to purge Air as follows:

Connect the High Side Gauge (on Gauge Manifold) to the Vapor Valve of the ERC Cylinder. Determine the ambient temperature and compare the gauge pressure to the pressure shown in the **Air Purge Chart** to the right.

If the ERC Cylinder pressure is greater, slowly open the Gauge Manifold Valve and allow Air to slowly escape until the pressure equals that shown in the chart.

The above purge process can be performed anytime during a recovery and while the ERC Cylinder is still above ambient temperature after a recovery procedure.

After the ERC Cylinder has cooled to ambient temperature, the Air can be purged to the pressure in a Standard Refrigerant Pressure/Temperature Chart.

NOTE:

A High-Pressure-Shutdown can be detected by noting that the Compressor-On Light goes OFF and there is still positive pressure at the Inlet of the TX200.

The Condenser Fan will continue to run and the TX200 Compressor may cycle Off and On as the Outlet Pressure rises and falls.

NON-CONDENSABLE PURGE CHART (BARS)

°C	R12	R22	R502	R134a
0	3.03	5.45	6.34	2.90
1	3.15	5.63	6.59	3.01
2	3.28	5.79	6.76	3.10
3	3.38	6.00	6.97	3.28
4	3.52	6.34	7.24	3.45
5	3.66	6.55	7.52	3.66
6	3.79	6.76	7.76	3.81
7	3.93	6.97	8.00	3.97
8	4.07	7.18	8.22	4.12
9	4.24	7.40	8.43	4.28
10	4.41	7.66	8.76	4.41
11	4.57	7.91	9.02	4.57
12	4.73	8.17	9.28	4.73
13	4.89	8.43	9.54	4.89
14	5.05	8.69	9.80	5.05
15	5.22	8.95	10.06	5.24
16	5.38	9.21	10.33	5.42
17	5.54	9.47	10.60	5.60
18	5.70	9.73	10.88	5.79
19	5.87	9.99	11.17	5.97
20	6.07	10.34	11.66	6.34
21	6.28	10.64	11.95	6.59
22	6.48	10.94	12.25	6.83
23	6.69	11.24	12.55	7.07
24	6.90	11.59	12.90	7.31
25	7.11	11.93	13.24	7.56
26	7.31	12.28	13.59	7.80
27	7.52	12.63	13.94	8.04
28	7.73	12.98	14.29	8.28
29	7.94	13.32	14.63	8.52
30	8.14	13.79	15.10	8.76
31	8.35	14.12	15.48	9.04
32	8.55	14.44	15.86	9.32
33	8.80	14.76	16.27	9.59
34	9.05	15.14	16.67	9.87
35	9.30	15.52	17.08	10.15
36	9.55	15.89	17.49	10.43
37	9.79	16.27	17.90	10.71
38	10.04	16.65	18.31	10.99
39	10.29	17.03	18.71	11.26
40	10.62	17.59	19.24	11.52
41	10.83	18.03	19.65	11.81
42	11.08	18.47	20.06	12.09
43	11.32	18.92	20.47	12.42
44	11.60	19.38	20.91	12.77
45	11.88	19.83	21.38	13.12
46	12.16	20.29	21.85	13.47
47	12.44	20.75	22.32	13.82
48	12.73	21.20	22.80	14.16
49	13.01	21.66	23.27	14.51
50	13.29	22.12	23.74	14.86

Procedure for Clearing TX200 between Refrigerants

The TX200 can be used to recover many different refrigerants. If the recovered refrigerants are to be recycled and/or reused, it is necessary to avoid mixing the different refrigerants. The TX200 will always contain a small amount of refrigerant within the internal components after each recovery procedure. This refrigerant must be cleared before recovering a different refrigerant. The following simple procedure can be performed to clear the refrigerant from all internal components of the TX200.

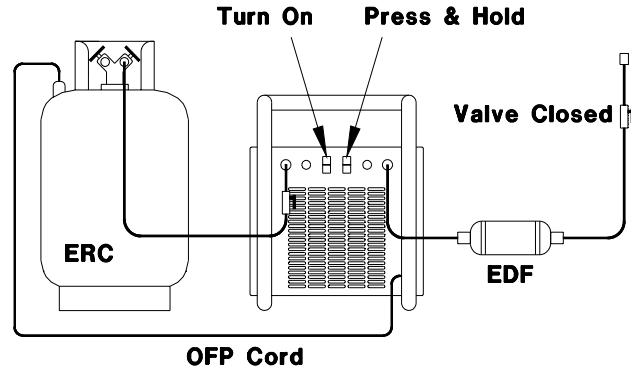

- 1) Connect the TX200 as shown above.
- 2) Open valve on ERC cylinder and valve on connecting hose. Close valve on inlet hose.
- 3) Turn power on. Press and hold DEEP VACUUM switch for one minute. This will remove any refrigerant from the inlet hose and EDF filter.
- 4) Turn power off, close all valves and disconnect hose and OFP cord from the ERC cylinder. This cylinder should be marked with the refrigerant type and stored for later use.
- 5) Connect an empty DOT cylinder to the TX200 and a vacuum pump as shown below.
- 6) Open both valves on the DOT cylinder. Do not open the valve on the hose connected between the DOT cylinder and the TX200.
- 7) Turn the vacuum pump on and let it run for ten minutes to place the DOT cylinder in a vacuum.
- 8) Close the valve of the DOT cylinder connected to the vacuum pump. Disconnect the vacuum pump from the DOT cylinder.
- 9) Open the valve on the hose connected between the DOT cylinder and the TX200. Any refrigerant in the TX200 will be pulled into the DOT cylinder.
- 10) Close all valves and disconnect the DOT cylinder from the TX200.
- 11) All refrigerant has been removed from the TX200 which can now be used to recover another type of refrigerant.

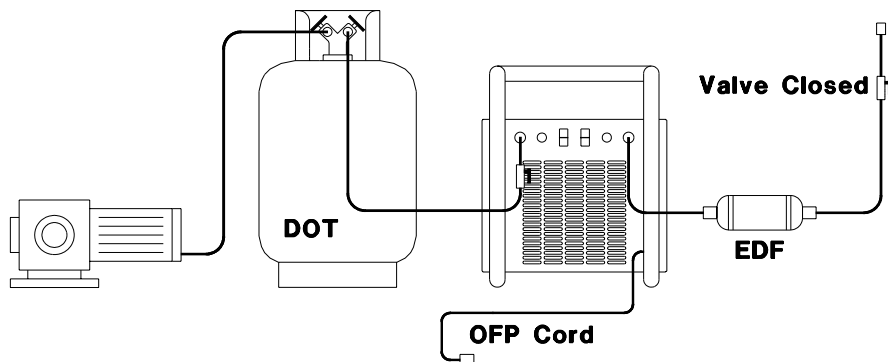

COMPRESSOR MAINTENANCE

BEFORE EACH USE...

Check the TX200 Compressor oil level before each recovery procedure. The Oil Level Sight Glass is visible through a cut-out on the side of the unit. The level should be maintained within the **lower half** of the sight glass.

Too much oil will cause the Compressor to be noisy; too little will cause it to overheat and may lead to piston or bearing failure.

ADD COMPRESSOR OIL...

Run the TX200 with the Inlet Hose Ball Valve closed until the Compressor On Light goes Off. Press and hold the Deep Vacuum Switch for approximately 30 seconds to draw a deeper vacuum. Leave the TX200 power on. Pour 3GS Compressor Oil into the measuring cup. Insert the end of the Inlet Hose into the Oil and slightly open the Ball Valve. Oil will be drawn into the TX200 due to the vacuum in the hose. Draw approximately 30 ml of Oil into the TX200 and close the valve. Use the TX200 for a recovery job and again check the oil level.

CHANGE COMPRESSOR OIL...

The oil in the Compressor should be changed every 90 days (or after approximately every 100 jobs or 50 hours of use). Change Compressor Oil as follows:

1. Disconnect power and remove cover.
2. Remove Caps from Vent Port (Upper) and Drain Port (Lower) on Compressor.
3. Remove Valve Cores from both ports and tip TX200 so Drain Port is at lowest possible level (approximately 45°).
4. Prop unit and allow Oil to drain for approximately 15 minutes.
5. Tip TX200 in opposite direction so the Drain and Vent Ports are at the highest possible level.
6. Use a syringe or oil injector at the Drain Port to re-fill the Compressor with 175 ml of Compressor Oil. Do not exceed a total of 225 ml.
7. Replace the Valve Cores and Caps on the two Compressor Ports. Replace TX200 Cover.
8. Let the TX200 sit in the normal (level) position for 30 minutes to allow the Oil to settle.
9. Follow the above procedure "TO ADD OIL" until the Oil level is visible within the lower half of the Oil Level Sight Glass.

CONDENSER MAINTENANCE

Clean the Condenser to maintain high efficiency performance of the TX200. Disconnect power and remove the Cover. Blow compressed air through the cooling fins of the Condenser to remove any debris.

Replace the Cover before applying power to the TX200.

EDF FILTER REPLACEMENT

Replace the EDF Filter according to the following:

Automotive	After every 100 Jobs
Commercial	After every Job Involving a Compressor Burn-out
	After every 20 Jobs Involving Normal Service

Refer to the Accessory Parts List at the end of this manual for ordering information.

SPR ADJUSTMENT

The TX200 has been factory adjusted and tested for optimum performance at operating temperatures from 10 to 49^o C. Adjustment of the SPR Valve was optimized to prevent High Pressure Shut Down during operation at higher temperatures.

Increased recovery rates can be obtained at normal operating temperatures (Approx 21^o C) by re-adjusting the SPR Valve. The following describes how to re-adjust the SPR:

1. Remove the TX200 Cover.
2. Remove the Cap from the Vent Port on the Compressor.
3. Connect a Low Pressure Manifold Gauge to this port. The hose used to make this connection must have a Valve Core Depressor.
4. Locate the SPR Valve which is silver in color and mounted just inside the Inlet Port of the TX200.
5. Use a screw driver to remove the Plastic Cap from the end of the SPR Valve to gain access to the SPR adjusting screw.
6. Connect the Inlet of the TX200 to a cylinder of R12 or R22 Refrigerant and operate the TX200 as described in the Recovery Mode of Operation section of this manual.
7. Use a screw driver to turn the SPR adjusting screw clockwise one full turn.
8. Turn the TX200 off and observe the pressure increase on the Gauge Manifold connected to the Compressor.
9. Turn the TX200 on and observe the pressure drop. This pressure will decrease and stabilize at the new "SPR Pressure Setting".
10. Repeat the above steps until the "SPR Pressure Setting" is 1.7 Bar.
11. Replace SPR Valve Plastic Cap, Compressor Vent Port Cap, and TX200 Cover.

NOTE... When using the TX200 at higher temperatures, a High Pressure Shutdown causes the Compressor On Light to go off, even though there is still pressure at the inlet of the TX200. The Condenser Fan will still be running.

Another way to prevent the TX200 from shutting down is to "throttle" the inlet pressure by slightly closing the Ball Valve on the Inlet Hose.

PROBLEMS & SOLUTIONS

On rare occasion the TX200 may seem to be performing differently or not at all. Experience has shown that varying operating conditions can affect the performance characteristics of the TX200. The temperature of the vehicle A/C System will affect how the TX200 performs.

Following are typical problems with explanations of the possible cause and solution.

PROBLEM: My TX200 was recovering refrigerant and the Compressor On light went OFF which indicates the A/C System should be in a vacuum. However, the Manifold Gauge still shows a pressure.

SOLUTION Determine if the Condenser Cooling Fan is still running. The fan can be heard and air flow through the TX200 can be felt. If the fan **is running**, the high pressure switch has shut the TX200 off due to an over-pressure condition.

Turn the Power Switch OFF and then ON. The condition may correct itself. This over-pressure will typically be due to excessive pressure in the External Cylinder caused by Non-condensable Gas (Air). Check the pressure in the ERC and vent until the pressure is equal to Saturation Pressure at the Ambient Temperature.

PROBLEM: My TX200 worked fine all last Summer. I got it out today for the first service job this Spring and it is very slow in evacuating the system.

SOLUTION: Today's Spring temperature may be much lower than the average temperatures during the summer months.

The refrigerant in the A/C System will not be under as high a pressure at lower temperatures and the TX200 will take longer to draw a vacuum. More cycles may be required to completely recover the refrigerant.

PROBLEM: I can not get the TX200 to draw a vacuum.

SOLUTION: Check Manifold Gauge and Hoses for restrictions.

If the above suggested solutions do not solve the problem, call Supplier and one of our technicians will help diagnose the cause. Please have the Serial Number available for reference.

ACCESSORY PARTS LIST

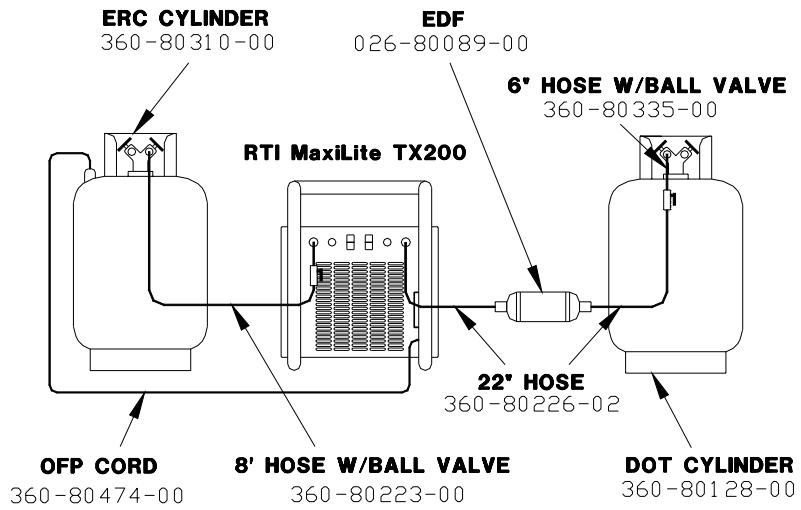

200F3.DWG

COMPRESSOR OIL (1 QT)
360-80171-00

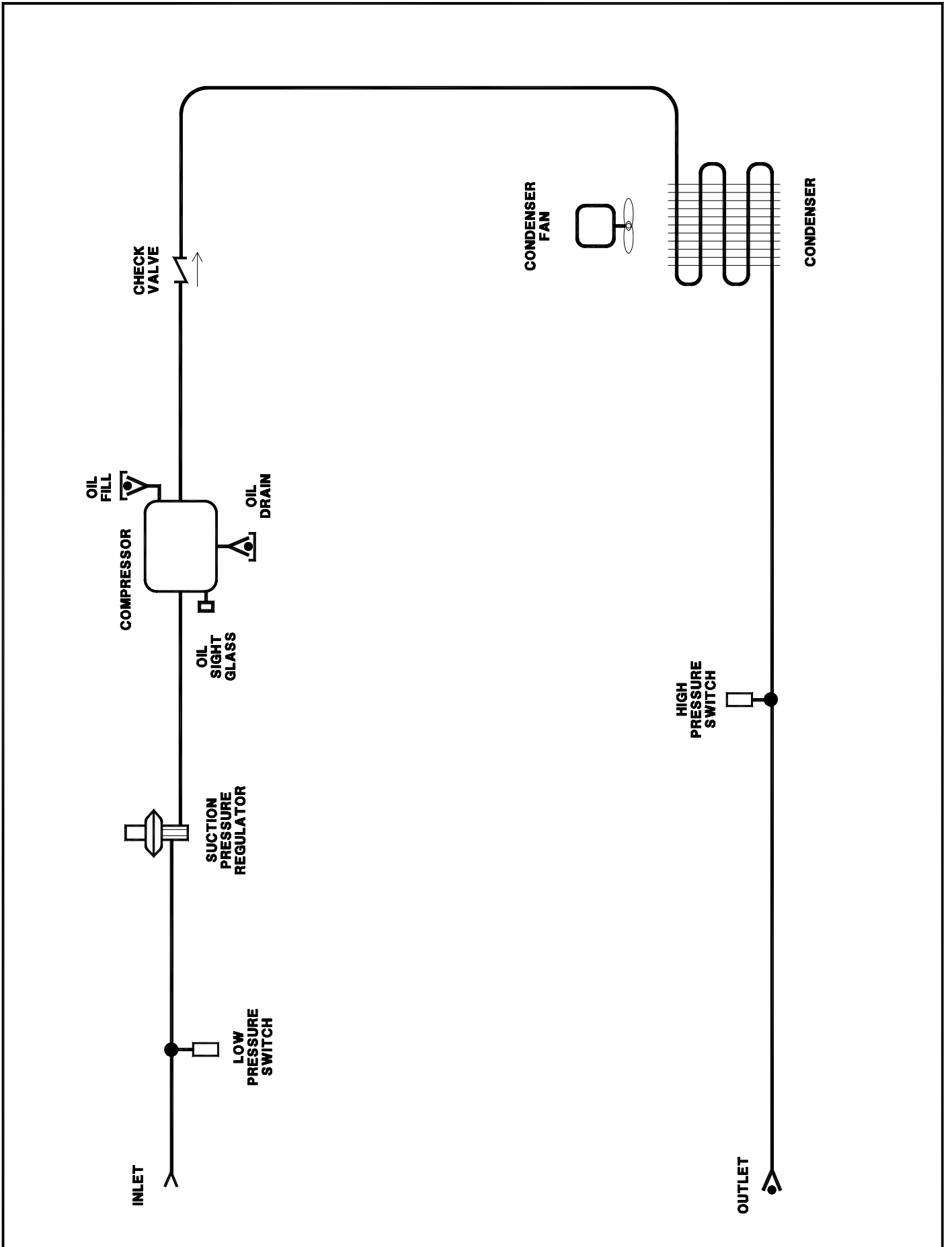

FLOW DIAGRAM - Model TX200

570-80252-00

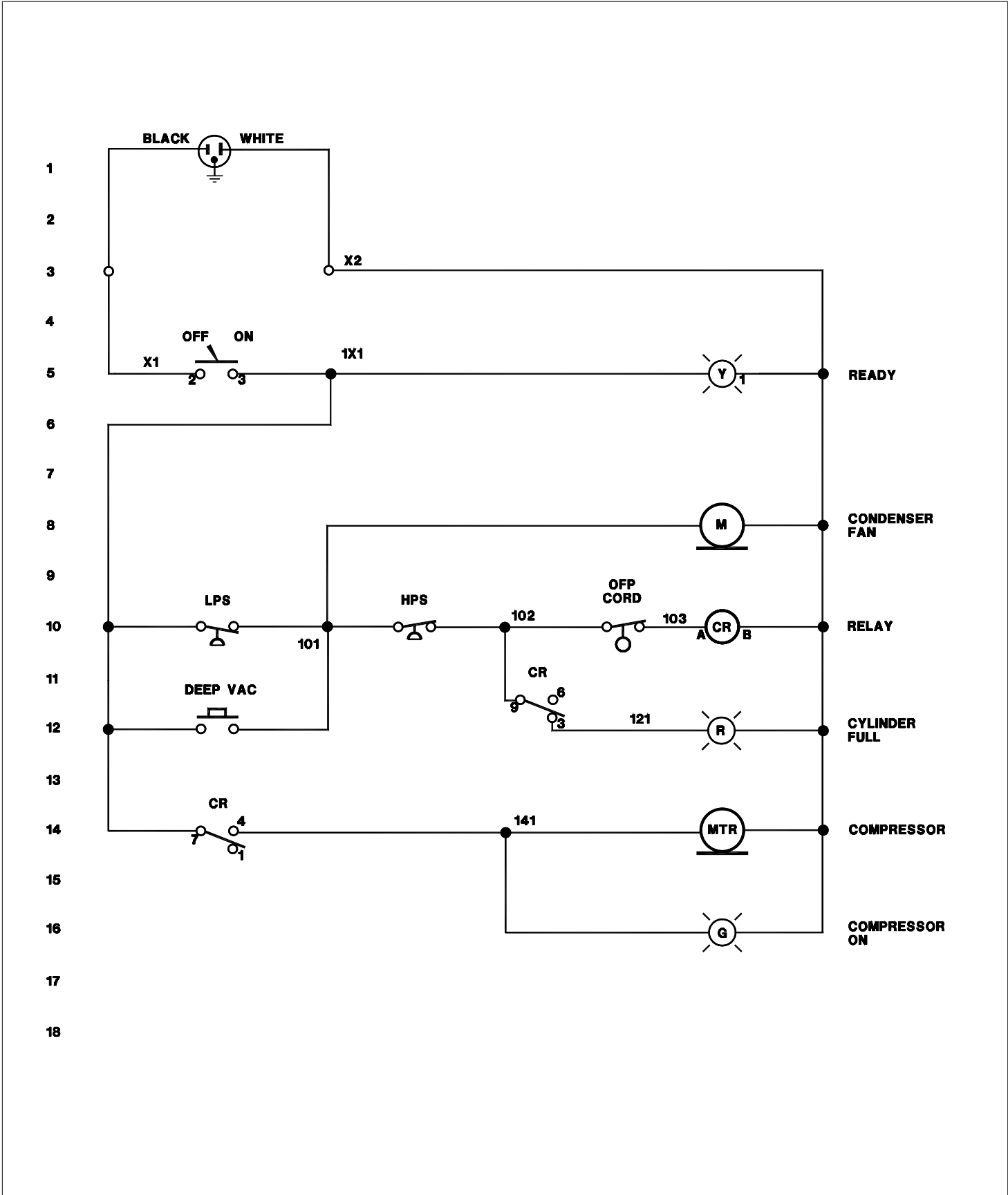

SCHEMATIC - Model TX200

570-80253-00