

# OPERATION MANUAL

## VCX-1

### Vacuum Coolant Exchanger



**RTI Technologies, Inc**

10 Innovation Drive

York, PA 17402

800-468-2321

[www.rtitech.com](http://www.rtitech.com)

Manual P/N 035-81443-00

# Table of Contents

Component Description . . . . .	2
Safety Precautions . . . . .	3
Home Position . . . . .	4
Fill New Tank through Hose . . . . .	5
Empty Radiator . . . . .	6
Special Hookups . . . . .	8
Fill Radiator . . . . .	9
Top Off . . . . .	10
Flush Radiator . . . . .	10
Empty Waste Tank . . . . .	11
Empty New Tank . . . . .	12
Troubleshooting . . . . .	13
Parts Identification . . . . .	14
Flow . . . . .	15

# Component Description

Unpack all components and verify quantities per this illustration.

Contact RTI if any items are missing.

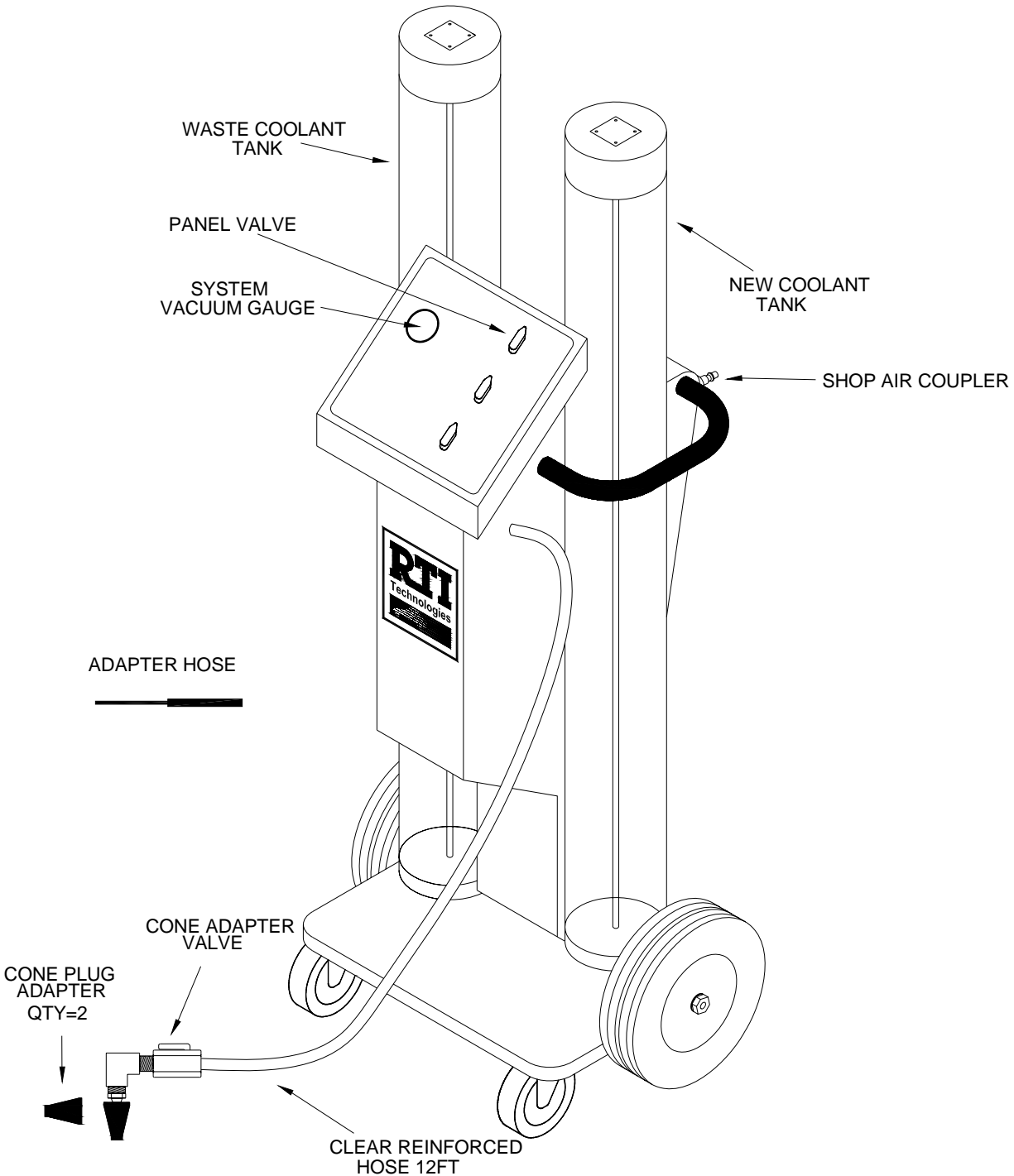

# Safety Precautions

**WARNING: Failure to follow these precautions can result in serious injury or death.**

- Your VCX Vacuum Coolant Exchanger was developed to provide you with years of trouble-free service in accordance with the utilization of proper inspection and maintenance techniques. It is important to understand this machine functions with its coolant cylinders either under pressure or vacuum, so it is imperative all cylinders receive proper inspection to ensure the proper and safe operation of the equipment is maintained throughout its life cycle.
- Read and understand the Operation Manual completely before operating this unit.
- Always wear proper skin protection when operating and maintaining this equipment.
- Always wear safety glasses when operating and maintaining this equipment.
- Before any VCX machine use it is required for the operator to visually inspect the coolant cylinders for defects such as cracks, nicks, gouges, chips, impact marks, fractures, hairline cracks, crazing, severe discoloration, cloudiness or hazing or other physical damage. **VISUAL TUBE INSPECTION IS REQUIRED PRIOR TO EACH MACHINE USE! IF ANY TUBES EXHIBIT ANY DEFECTS, THEY MUST BE REPLACED BEFORE MACHINE OPERATION! FAILURE TO COMPLY MAY RESULT IN TUBE FAILURE AND POSSIBLE INJURY!**
- Automotive cooling systems can be under pressure and extremely hot. Place a rag over the radiator cap during removal to avoid injury. Use extreme caution when removing caps.
- Coolants are corrosive and poisonous to people and animals. Clean up any spills immediately.
- Do not allow waste coolant tank to overflow. Immediately clean up any coolant spills. Damage to the vehicle and equipment can result from the corrosiveness of coolant.
- Continuous monitoring of the coolant exchange process is required.
- Unit is equipped with factory preset pressure regulator. Do not attempt pressure adjustment without RTI Technical Support authorization.
- If cracks appear in the cylinders, hoses or adapters these parts must be replaced.
- If VCX unit tipped over, resulting in a fall of the machine onto any side, it is mandatory all coolant tubes be replaced immediately before the machine is placed back into service.
- If leaks occur at the bottom or top of the cylinders, contact RTI for troubleshooting instructions.
- The cylinders, hoses and adapters are plastic and rubber products and are in contact with oil and chemicals which may lessen their durability. Therefore, when soiled, they should be cleaned with water and a mild detergent. **Caution: Do not clean with thinners, solvents or any other chemical cleaners.**
- Only disassemble or reassemble unit parts when directed by an RTI representative.
- Take precautions to keep clothing, hair, hands, hoses, etc. away from all moving parts of the vehicle.
- Comply with local, state and federal regulations for fluid disposal.
- **Material Safety Data Sheets (MSDS)** must be obtained on all chemicals and placed in a shop file for reference. These are available for down load and printing on the RTI web-site ([www.rtitech.com](http://www.rtitech.com)). Go to TECHNICAL HELP and look under Technical Bulletins.

**CAUTION: Failure to follow the precautions as outlined in the operation manual can result in damage to the engine, vehicle or equipment which will not be supported or covered under warranty.**

# Home Position

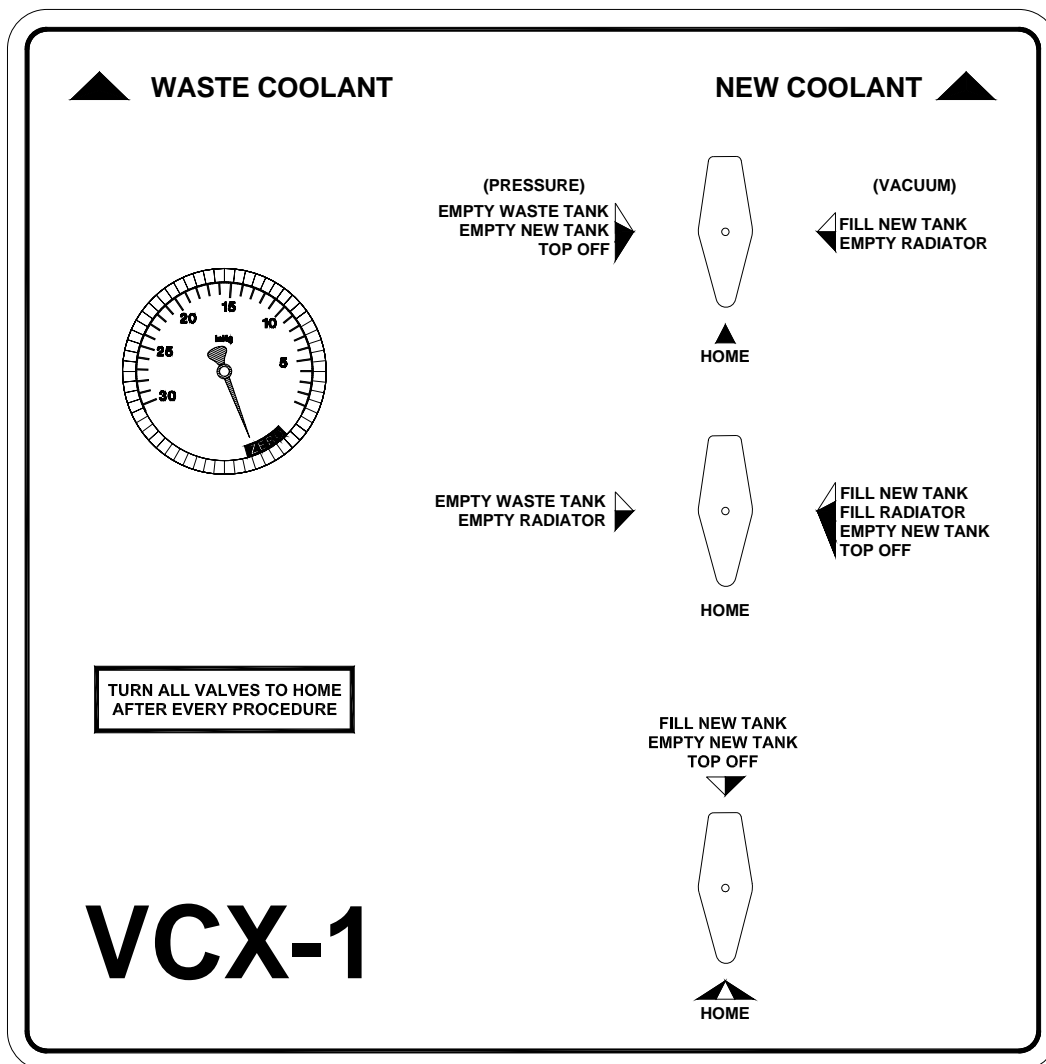

The above valve configuration is set before the VCX is connected to the shop air supply. This is also the position that the valves are returned to after each procedure. To select a procedure turn all of the valves to the colored triangle that corresponds with the desired procedure.

This illustration demonstrates the open and closed position on the Cone Adapter Valve. The closed position is 90 degrees clockwise from center.

## Cone Adapter Valve

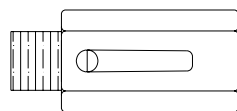

Valve Open

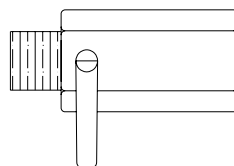

Valve Closed

# Fill New Tank through Hose

1. Turn all panel valves to the Home position.
2. Connect shop air to VCX Shop Air Coupler.
3. Turn all panel valves to the Fill New Tank position as shown in the illustration below. This orientation can also be obtained by positioning the panel valves toward the green highlights closest to each valve.
4. Place the Cone Adapter, with the Adapter Hose attached, into the container of new coolant. Open the Cone Adapter Valve to draw coolant into the New Coolant Tank.
5. Raise the hose out of the container of new coolant when the desired fluid level is reached in the New Coolant Tank.
6. Close the Cone Adapter Valve.
7. Turn all valves to the Home position when done.

**Note: DO NOT OVERFILL.**

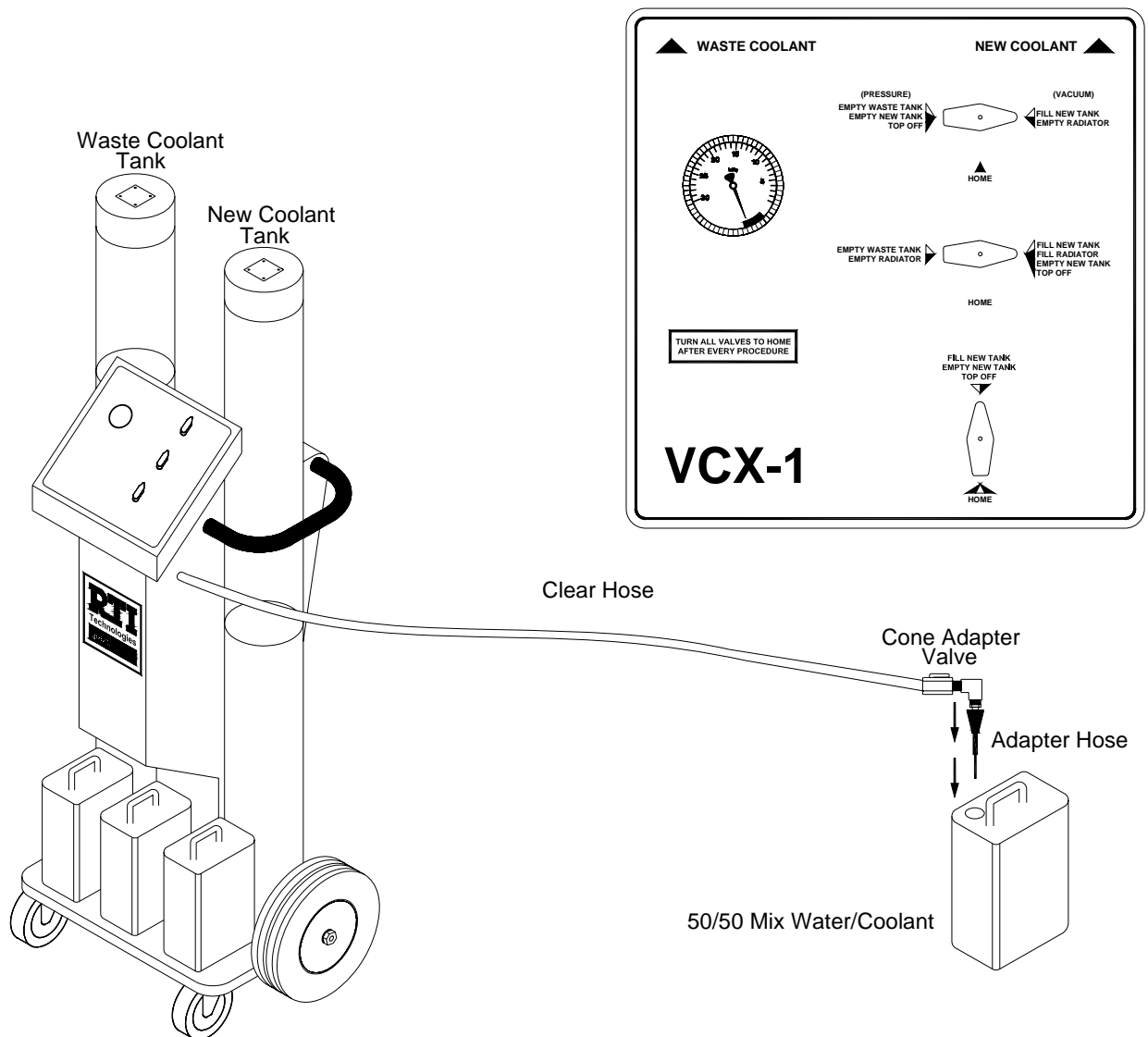

# Empty Radiator

1. Run the vehicle with the heater turned on to bring the engine to operating temperature. Turn the engine off.
2. Turn all panel valves to the Home Position as shown on page 4.
3. Connect shop air to VCX Shop Air Coupler.
4. Turn all panel valves to the Empty Radiator position as shown in the illustration below. This orientation can also be obtained by positioning the panel valves toward the black highlights closest to each valve.
5. Insert the Adapter Hose into the Cone Adapter. Insert end of Adapter hose into overflow tank. Turn the Adapter Hose Valve to the open position to withdraw the coolant.

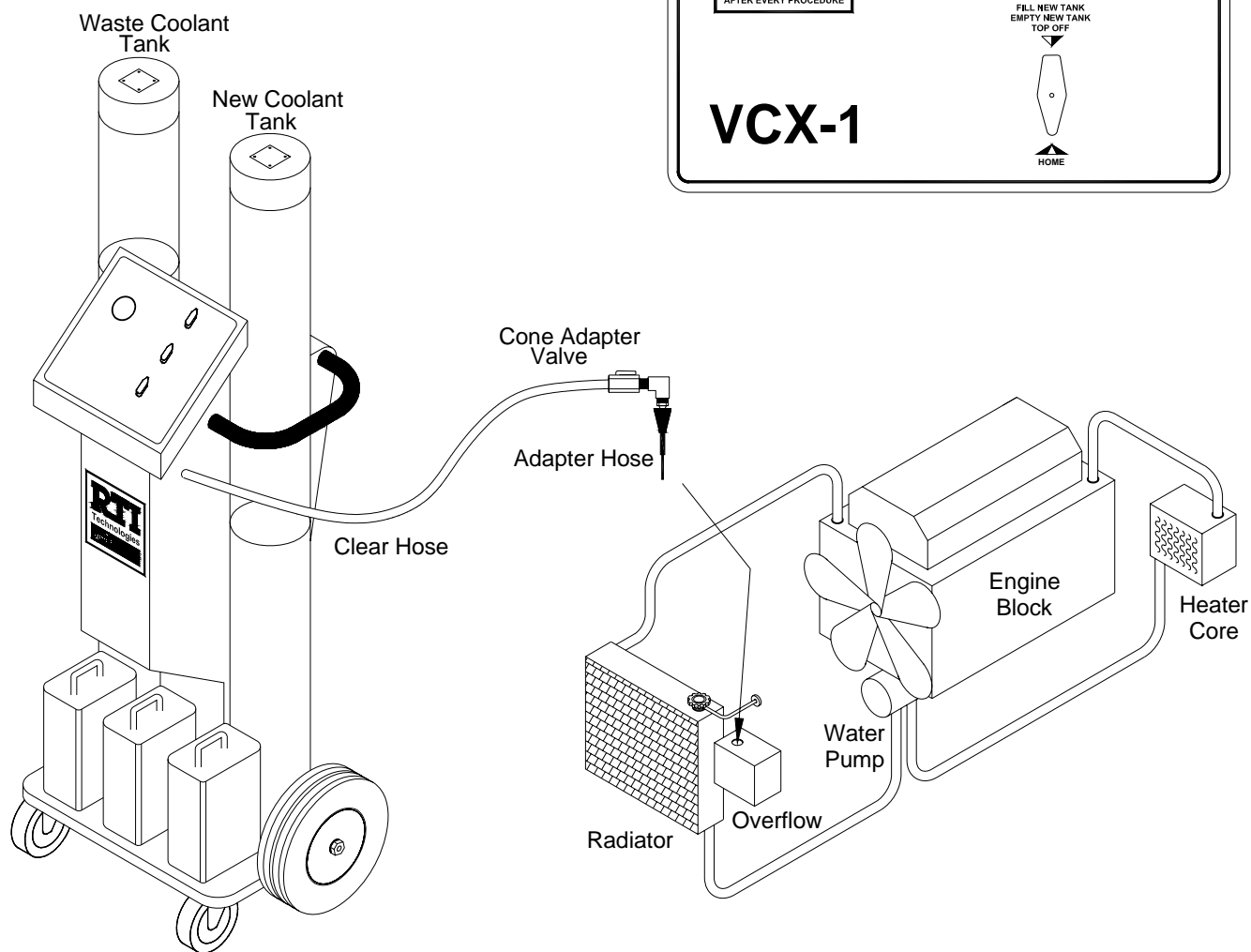
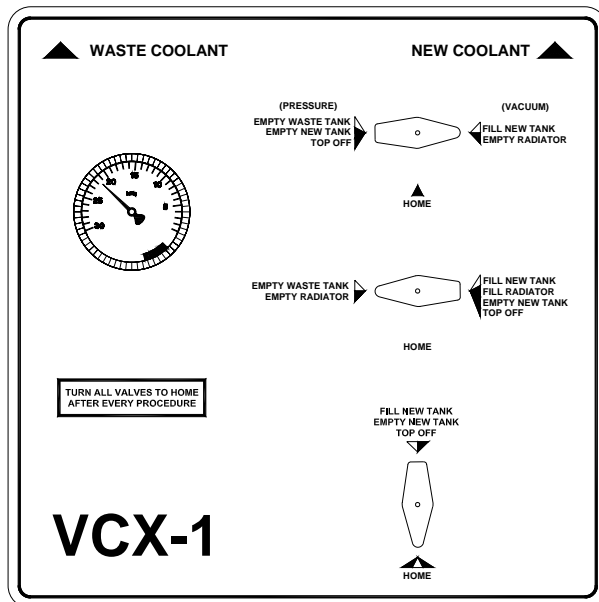

# Empty Radiator (Continued)

6. **Carefully** remove radiator cap. Use a shop rag over the cap when removing to avoid injury in case there is still pressure.
7. Place VCX Cone Adapter snugly into the radiator spout. Do not force the Cone Adapter into the spout, the suction pressure from the VCX should secure it adequately. Verify that the Cone Adapter Valve is in the open position.
8. Start the engine once fluid starts to move through the clear hose and into the VCX Waste Coolant Tank. Verify that the System Vacuum gauge reads at least 22 InHg.
9. Once the waste coolant from the vehicle stops flowing through the clear hose, turn all of the panel valves to Home Position and **turn the engine off**.

**DO NOT REMOVE CONE ADAPTER FROM THE RADIATOR!**

**Note:** In some cases it may be necessary to pinch off the hose going from the radiator neck to the overflow container. This is only necessary when the vacuum leaks through this hose. The hose should be opened only after the Fill Radiator procedure.

**WARNING**  
Do not overfill the Waste Tank.

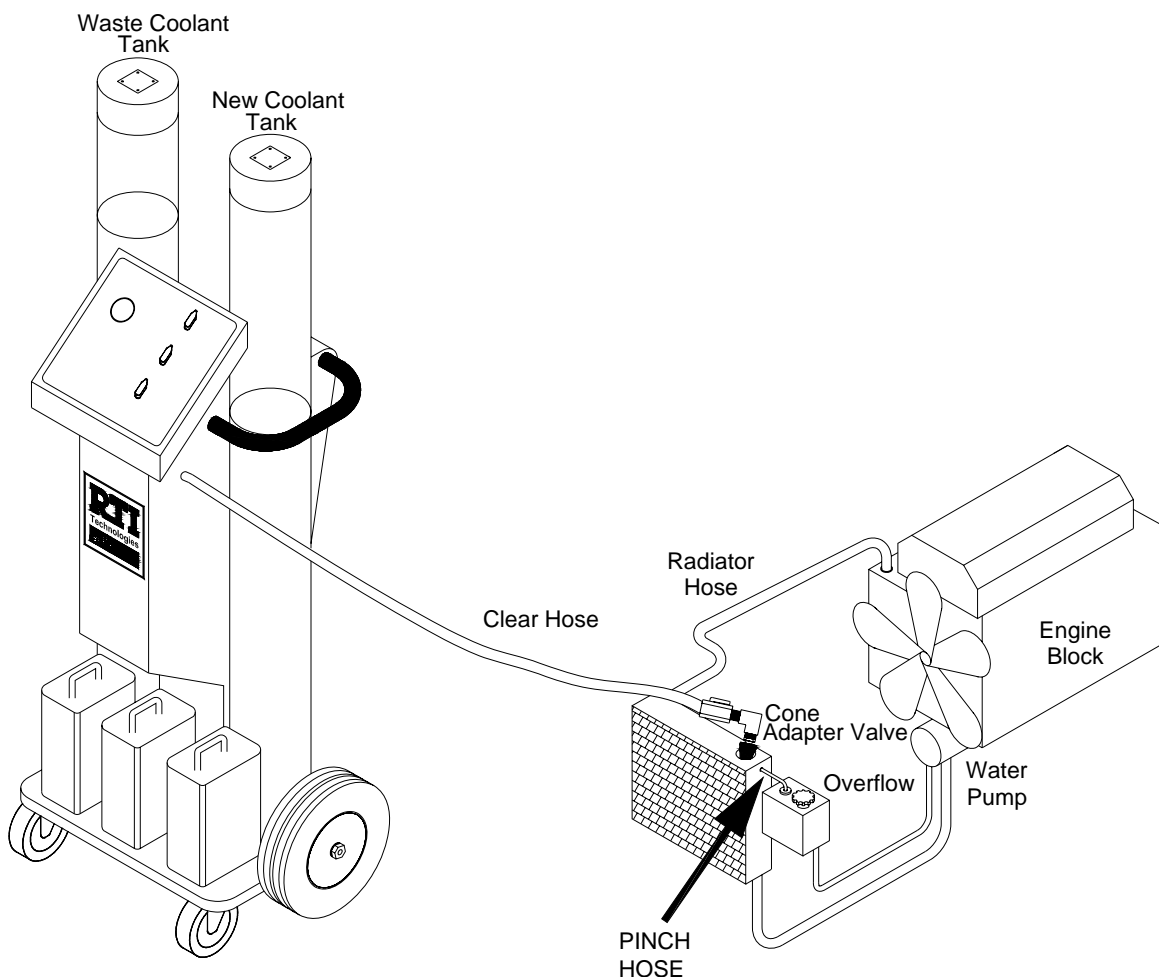

# Special Hookups

## Seal Tight Radiator

1. Insert the Adapter Hose into the end of the Cone Plug Adapter.
2. Place the Cone Adapter snugly into the radiator, coiling the excess length of Adapter Hose at the bottom.
3. Follow the Empty Radiator procedure steps 1-9.

## More Effective Setup for Empty Radiator

During the Empty Radiator procedure clamp off the upper radiator hose and follow steps 1-9 of the Empty Radiator section.

## Adapter Seal

1. In some cases it may be necessary to cut up to 0.75" off of the Cone Plug Adapter. This is only necessary when a tight seal can not be created due to bottoming out against the inside of a shallow radiator neck.
2. Take care to cut a clean edge free of loose debris.

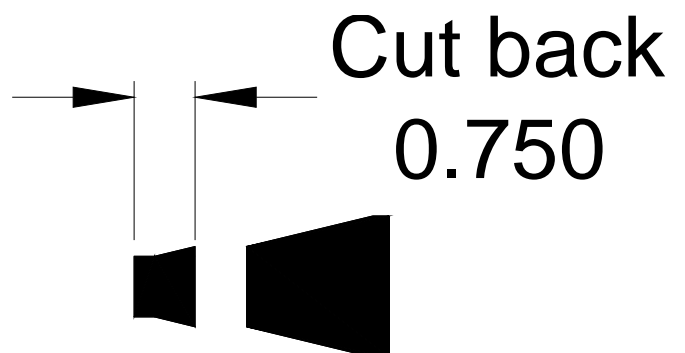
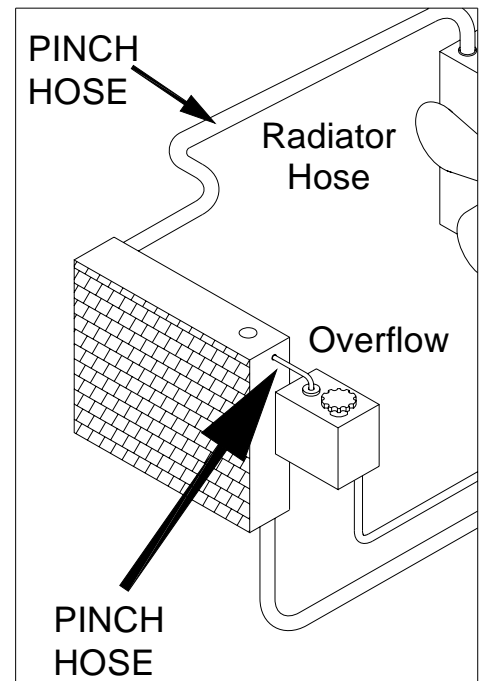

# Fill Radiator

## Fill Radiator

**MAKE SURE THE ENGINE IS OFF**

1. Turn all panel valves to the Home position.
2. Turn all panel valves to the Fill Radiator position shown in the illustration below, this orientation can also be obtained by positioning the panel valves toward the magenta highlights closest to each valve. Verify that the Cone Adapter Valve is open.
3. New coolant is automatically pulled out of the VCX New Coolant Tank and into the vehicle radiator through the clear hose.

**NOTE: IF THE CONE ADAPTER BECOMES DISLODGED BEFORE YOU CAN BEGIN THIS PROCESS YOU MUST RERUN THE EMPTY RADIATOR FUNCTION, WITHOUT STARTING THE VEHICLE, TO REGAIN THE VACUUM NEEDED TO FILL THE VEHICLE COOLANT SYSTEM.**

4. Once the coolant stops moving through the clear hose turn all of the panel valves back to the Home position and remove the Cone Adapter from the radiator.
5. Turn all valves to the Home position.
6. Close the Cone Adapter Valve.

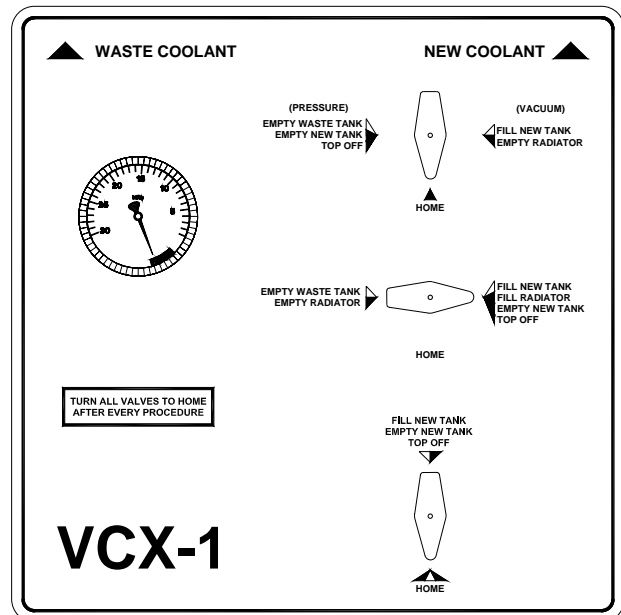

# Top Off

1. Turn all panel valves to the Home position.
2. Turn the Cone Adapter Valve to the closed position.
3. Turn all panel valves to the Top Off position as shown in the illustration. This orientation can also be obtained by positioning the panel valves toward the blue highlights closest to each valve.
4. Open the Cone Adapter Valve to fill the radiator and overflow to the proper levels.
5. Turn all valves to the Home position.
6. Close the Cone Adapter valve when done.
7. Replace radiator and overflow caps.

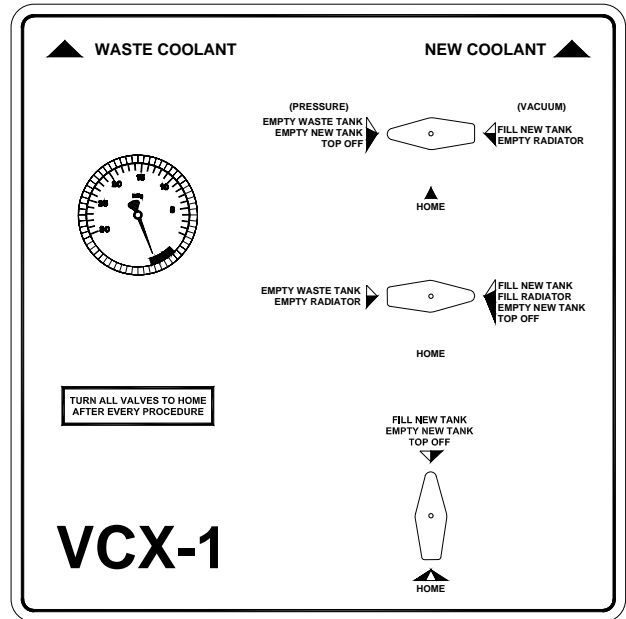

## Flush Radiator

1. The New Coolant Tank needs to be filled with water. See Empty Waste Tank and Fill New Tank procedures.
2. The Empty Radiator function must be run to completion.
3. Run the Fill Radiator procedure.
4. The Empty Radiator function must be run again to extract all of the water inside the cooling system.
5. Repeat steps 3 and 4 until the desired results are achieved. Once completed new coolant needs to be added to the vehicle system.

# Empty Waste Tank

1. Turn all panel valves to the Home position.
2. Connect shop air to VCX Shop Air Coupler.
3. Close Cone Adapter Valve.
4. Turn all panel valves to the Empty Waste Tank position shown in the illustration below. This orientation can also be obtained by positioning the panel valves toward the red highlights closest to each valve.
5. Place the end of the clear hose into a bulk waste container and open the Cone Adapter Valve.
6. Waste coolant will begin leaving the VCX from the Waste Coolant Tank through the clear hose. Be cautious not to spill waste coolant onto the floor as the hose may “jump” when the Waste Coolant Tank is nearing empty. Clean up any spills that may occur immediately.
7. Once the Waste Coolant Tank is empty, close the Cone Adapter Valve and turn all valves to the Home position.

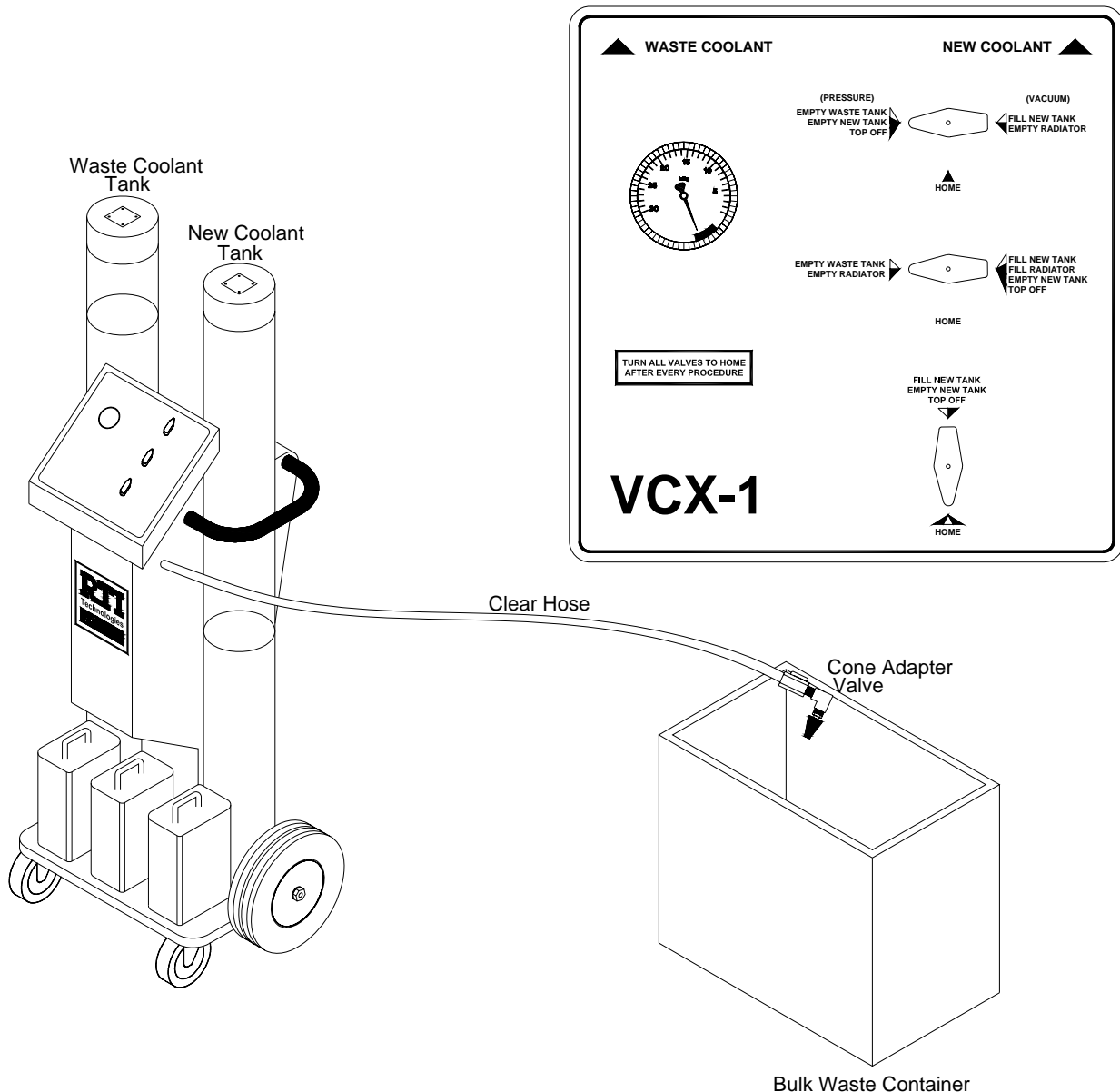

# Empty New Tank

1. Turn all panel valves to the Home position.
2. Connect shop air to VCX Shop Air Coupler.
3. Close Cone Adapter Valve.
4. Turn all panel valves to the Empty New Tank position shown in the illustration below. This orientation can also be obtained by positioning the panel valves toward the blue highlights closest to each valve.
5. Place the end of the clear hose into a bulk storage container and open the Cone Adapter Valve.
6. Coolant will begin leaving the VCX from the New Coolant Tank through the clear hose. Be cautious not to spill coolant onto the floor as the hose may “jump” when the New Coolant Tank is nearing emptiness. Clean up any spills that may occur immediately.
7. Once the Waste Coolant Tank is empty, close the Cone Adapter Valve and turn all valves to the Home position.

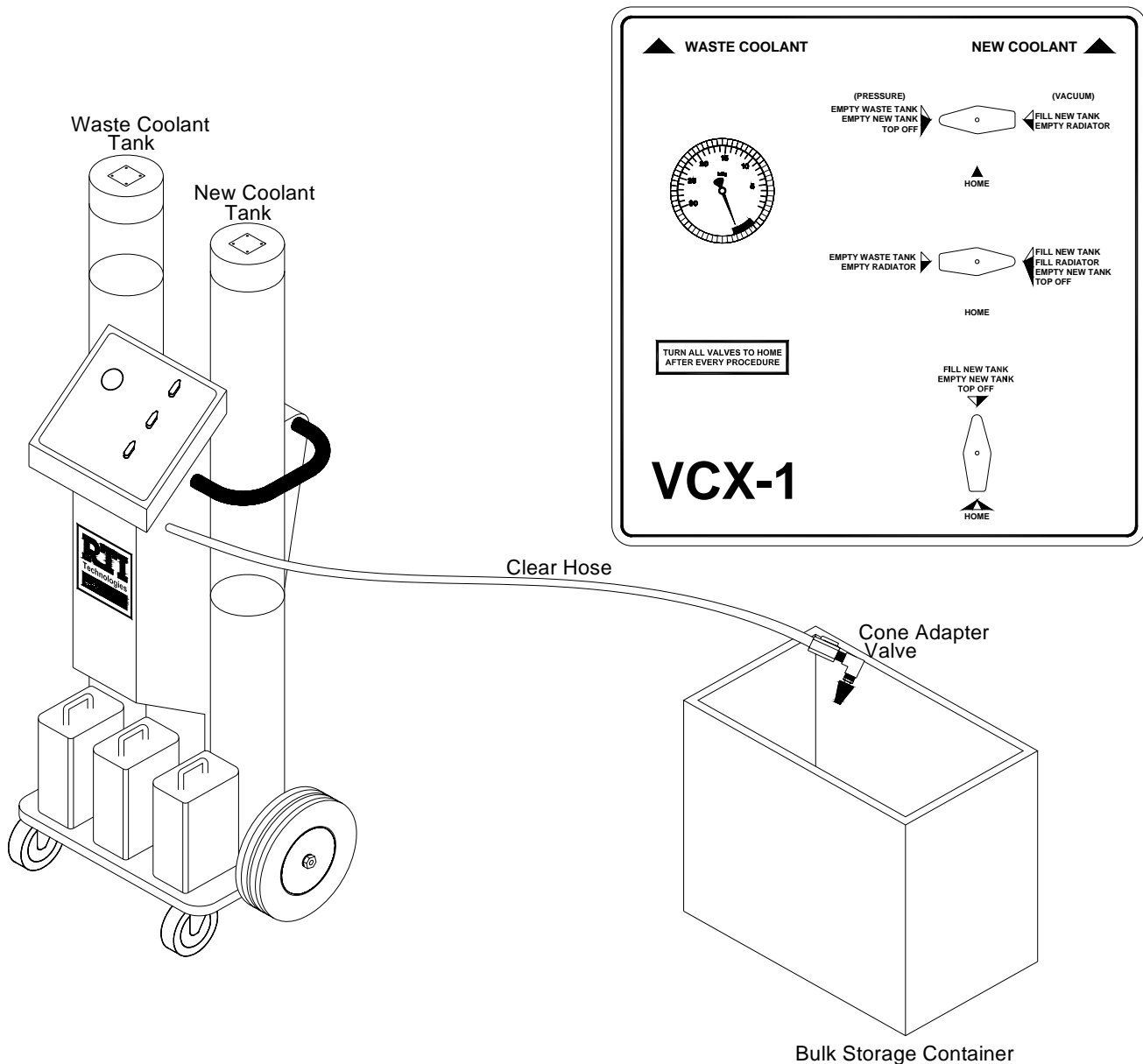

# Troubleshooting

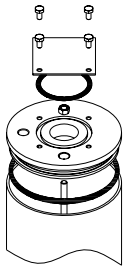
Problem	Solution
Vacuum becomes weak	<p>Inside of the VCX, there is a venturi vacuum generator that may have collected debris during the operation of the unit. If this occurs, the vacuum will become weak resulting in a lower vacuum reading on the System Vacuum gauge and poor performance. Remove the venturi from the line and blow shop air through it. Use the Parts Identification (page 14) to locate the venturi. Reconnect to correct lines when done.</p> <p>There may be a vacuum leak at either the top or bottom sealing point on the tanks. Fill the tank to the top with water and turn all valves to the Home position. Close the Cone Adapter Valve and turn all valves to the Empty (leaking tank) position. Check for leaks and follow guidelines from the Leakage section.</p>
Leakage 	<p>Debris may have collected at the bottom of the tank. Disassemble tank and clean the base of tank. Take care when reassembling not to over tighten the hex nut (use 60 lb/in torque wrench). Do not use pneumatic or power tools.</p> <p>Over time, the o-ring at the bottom or top of the cylinder may become worn. Inspect and replace if needed. See part break down on left.</p>
Tank Overflow	<p>If fluid is ever filled to the top of the tank while using the unit there is a device that will release excess to the inside of the cabinet.</p>
External Clear Hose	<p>Using the VCX to remove coolant from a vehicle creates high temperatures throughout the unit particularly where the clear hose connects to the Cone Adapter. Repeated exposure to these temperatures may cause deterioration of the hose. If possible cut affect area off and reconnect Cone Adapter. If replacement of the hose is required call RTI.</p>

	P/N	Description
1	060-81693-00	Top Cylinder Plate
2	060-81692-00	Bottom Cylinder Plate
3	060-81695-00	Fiberglass Tube (52 inches)
4	035-81433-00	Tank Level Decal
5	028-80465-00	Large O-Ring
6	026-80238-00	Vacuum Gauge 30"-0 PSIG
7	022-80028-00	Ball Valve 3-Way 1/4 FPT (BHD)
8	028-80228-00	Small O-Ring
9	022-80153-00	Valve Relief 1/4 MPT X 1/4 FPT
10	370-80095-00	Clear Hose Assy
11	026-80197-00	Vacuum Pump (Venturi)
12	370-80075-00	Pressure Regulator 1/4 FPT X 1/4 FPT (BHD)
13	060-81215-00	Cone Plug Adapter
14	370-80168-00	Cone Adapter Valve Assy
15	370-80095-00	Adapter Hose

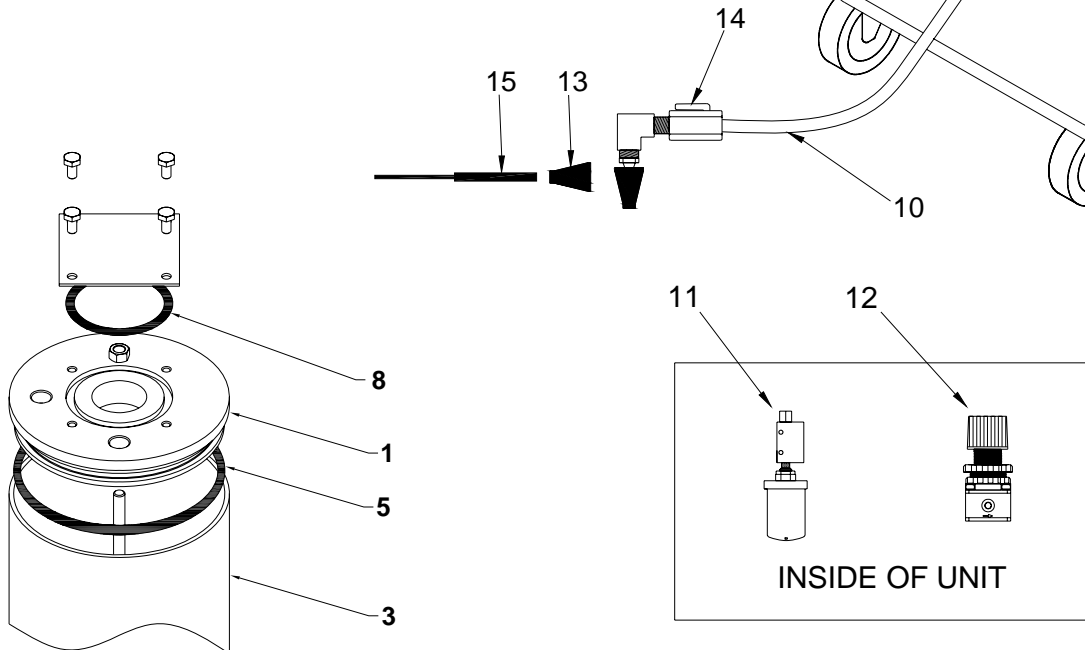
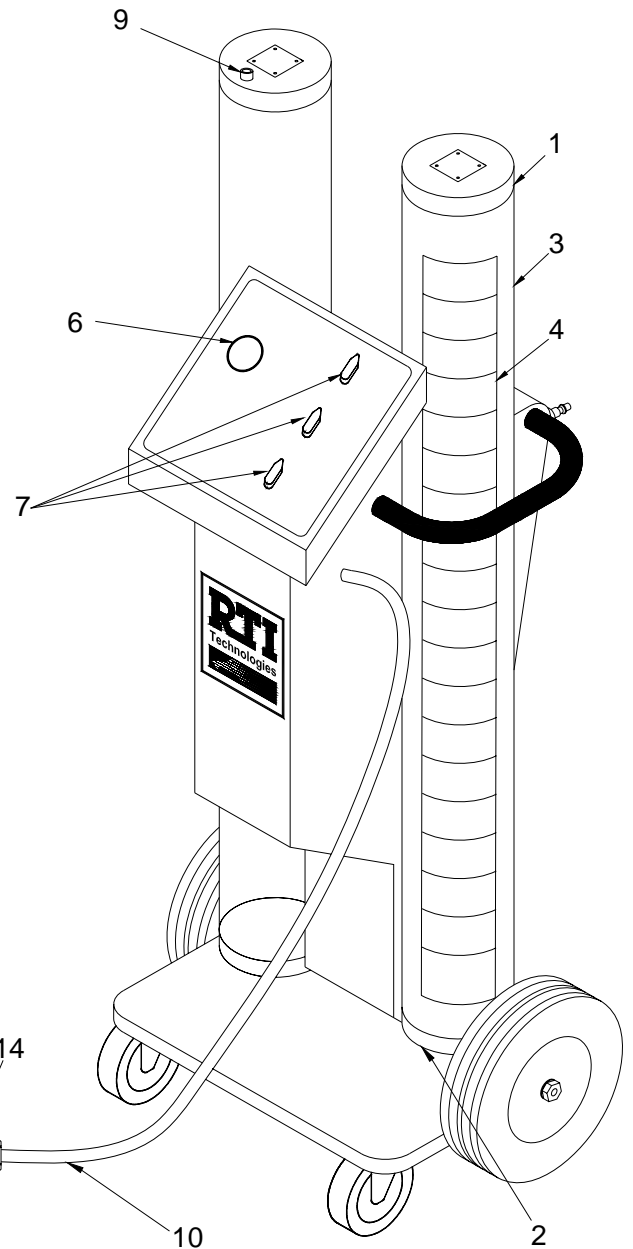

# Flow

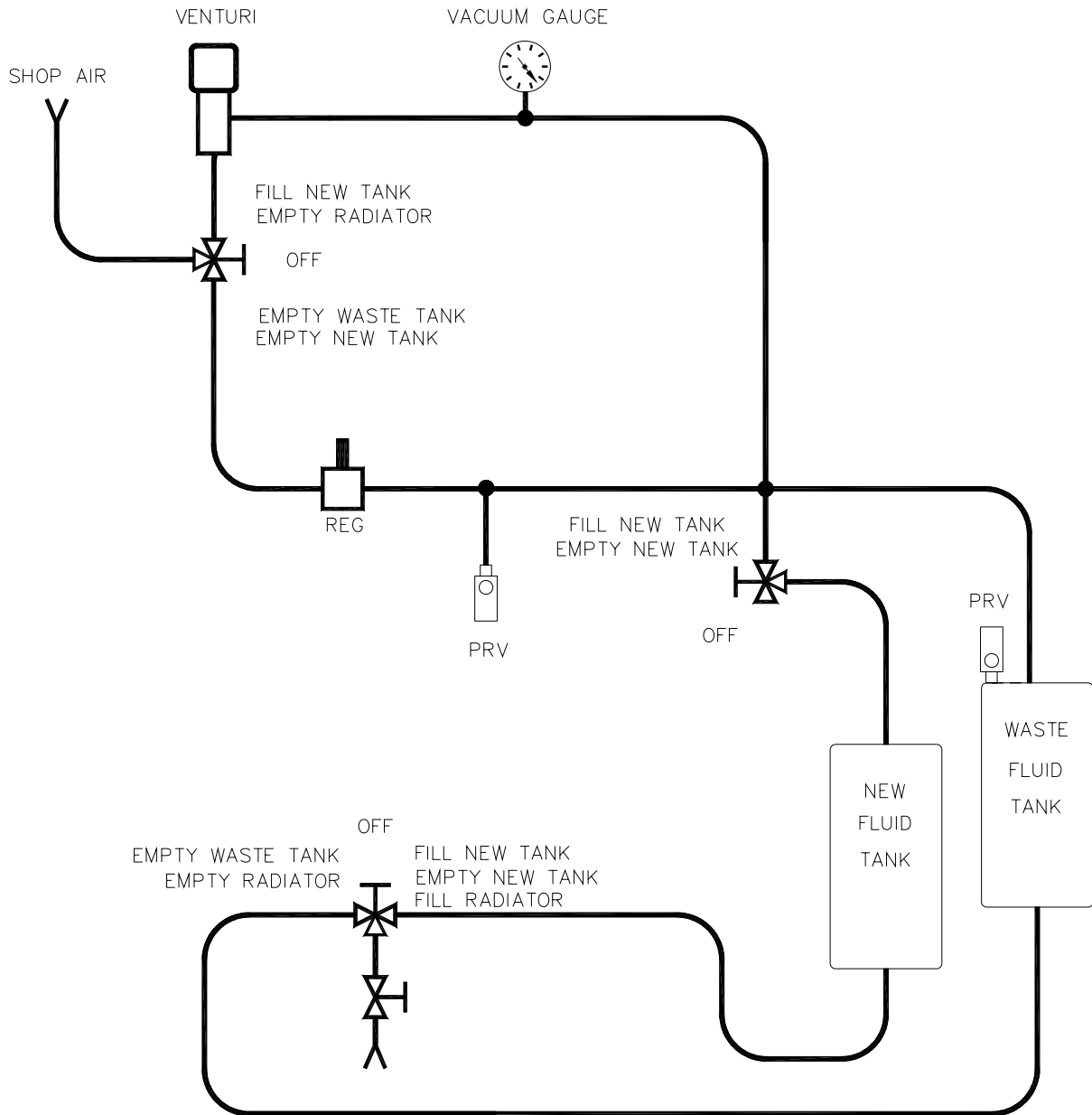

**NOTES:**