

OPERATION
&
MAINTENANCE
MANUAL

TX600

RTI TECHNOLOGIES, INC.

4075 East Market Street
York, PA 17402

Manual P/N 035-80118-00

! TABLE OF CONTENTS !

TX600

Before Using	Page 2
Safety Precautions	Page 3
Recycle Mode Of Operation	Page 4
Oil Drain & Rapid Air Purge System Procedure	Page 7
How The TX600 Works	Page 10
Scheduled Maintenance	Page 12
Change Compressor Oil	Page 12
Combo Filter Maintenance	Page 13
Problems & Solutions	Page 14
Flow Diagram	Page 16
Circuit Diagram	Page 17
TX600 Assembly Instructions	Page 18

CONGRATULATIONS: You have purchased one of the finest R12 Recovery and Recycling Machines available at any price.

Save shipping carton for use in returning the TX600 to the manufacturer in the event that service would be required.

BEFORE USING THE TX600

Check for any shipping damage. Place a claim with carrier if damage is discovered.

DO NOT USE A DAMAGED UNIT.

Mount Wheels and Handle, following the assembly procedure provided in the Appendix and with the Accessory Kit.

Refer to the Maintenance Section of this manual and verify that the Compressor oil level is as shown. If not, do not apply power to the unit. Call 717-840-0678 (Ext. 259) for instructions.

Complete and return the Warranty Card within 90 days to activate technical support service and warranty coverage.

Warranty claims can not be honored without this warranty card on file.

The TX600 should not be operated or serviced by any person who has not read all the contents of this manual. Failure to read and comply with these instructions or any one of the limitations noted herein can result in serious injury and/or property damage.

These general instructions deal with the normal operation and maintenance situations encountered with the TX600. The instructions should not be interpreted to anticipate every possible contingency.

It is the responsibility of the owner/user to operate the TX600 in accordance with all specifications and laws which may apply.

The following pages contain rules for safe operation of the TX600. Taking precedence over any specified rule listed herein, however, is the most important rule of all:

"USE COMMON SENSE"

A few minutes spent reading these instructions can make an operator aware of dangerous practices to avoid and precautions to take for his own safety and the safety of others.

A regular schedule of inspection of the TX600 should be established and records maintained with special attention given to Hoses, Compressor Oil Level, Moisture Indicator, and Filters.

SAFETY PRECAUTIONS

- ! Recover and Recycle R12 refrigerant only.
- ! Wear safety glasses and protective gloves. Refrigerant has a very low boiling point and can cause frostbite.
- ! Follow the TX600 operating procedures sequentially to avoid prematurely disconnecting hoses or opening valves which may release refrigerant to the atmosphere.
- ! Do not expose the TX600 to moisture or operate in wet areas.
- ! Use the TX600 in locations with mechanical ventilation that provides at least four air changes per hour or locate the unit 18 inches above the floor.
- ! Hoses used with the TX600 must have shutoff devices within 12 inches of the connection point to the system being serviced to minimize the introduction of Non-condensable Gas (Air) into the TX600 and the release of refrigerant when being disconnected.
- ! Disconnect power before performing any maintenance or service on the TX600.
- ! Avoid using an extension cord with the TX600. If necessary, use a good condition, UL listed, 3-wire grounded, #14 AWG extension cord of the shortest possible length.
- ! Connect the TX600 to a properly protected, grounded receptacle. Do not over load the circuit.
- ! **Disconnect Power Cord from power source while connecting the OFP (Overfill Protection) Device to avoid bodily injury due to electrical shock. Do not force plug into OFP Device. Look at pins in plug and align them with sockets on OFP Device.**

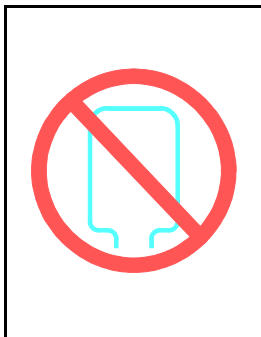

NEVER TURN THE CYLINDER UP-SIDE-DOWN.

DO NOT CONNECT THE TX600 TO THE LIQUID SIDE OF ANY A/C SYSTEM WITH A CAPACITY GREATER THAN 4 LBS.

REFRIGERANT IN A/C SYSTEMS HAVING LARGER CAPACITIES MUST BE RECOVERED FROM THE VAPOR SIDE ONLY.

FAILURE TO FOLLOW THE ABOVE MAY CAUSE THE TX600 COMPRESSOR TO FAIL AND VOID THE WARRANTY.

RECYCLE MODE (Refer To Figure I)

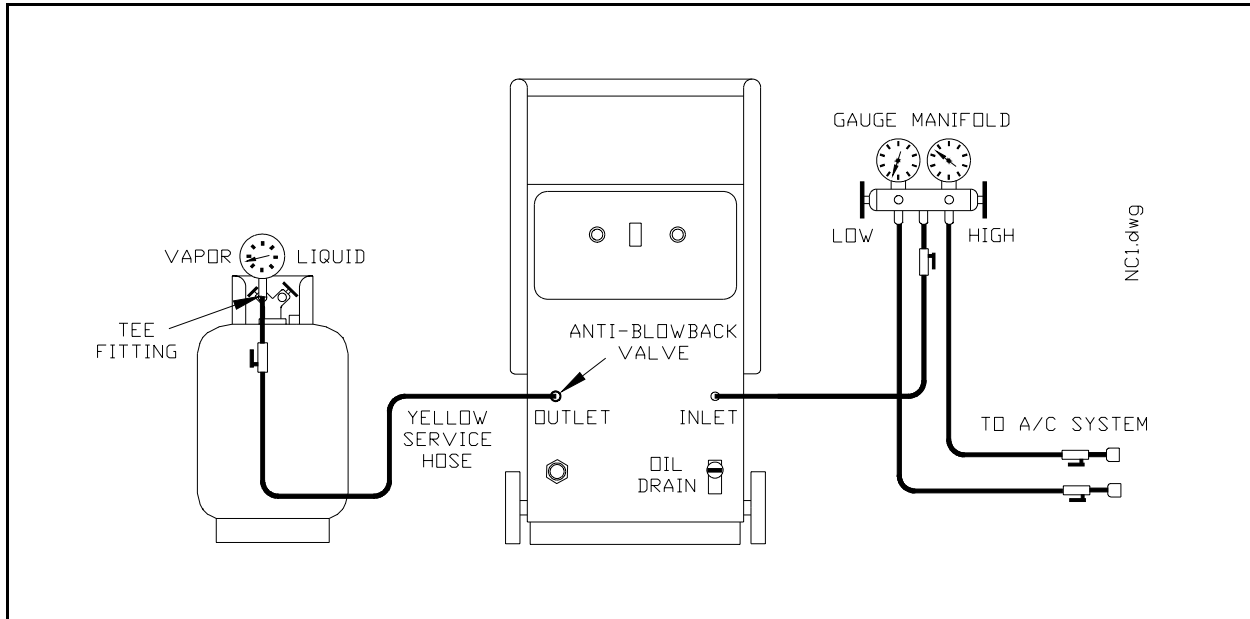

FIGURE I Connections For Recycle Mode

Install Tee Fitting on **VAPOR** Port of Refrigerant Cylinder. Remove Valve Core, if any, from Tee Fitting.

Connect Pressure Gauge on branch of Tee Fitting.

Connect end of Yellow Service Hose with Shut-off Valve to Tee Fitting. Install Anti-Blowback Valve on other end of hose and connect to Outlet of TX600 (Refer to Figure I). *Leave Hose connected to Outlet unless TX600 repair or transport is required.*

Connect Yellow Service Hose from Inlet Port of TX600 to center port of Gauge Manifold. Shut-off Valve must be on end connected to Gauge Manifold (Refer to Figure I). *Leave Hose connected to Inlet unless TX600 repair or transport is required.*

WARNING... Refrigerant Cylinder must have an **Overfill Protection (OFP) Device**.

Disconnect Power Cord from power source while connecting the OFP (Overfill Protection) Device to avoid bodily injury due to electrical shock.

Connect Yellow Cable from rear of TX600 to OFP Device on Refrigerant Cylinder. A receptacle on the lower rear of the TX600 can be used to store the Plug when not connected to OFP Device on Cylinder during non-use to prevent debris from collecting inside the housing.

CAUTION... Do not force plug into OFP Device. Look at pins in plug and align them with sockets on OFP Device.

Attach High and Low Gauge Manifold Hoses to A/C system per manufacturer's instructions.

Connect TX600 Power Cord to a properly protected, grounded receptacle. Avoid using an extension cord. If necessary, use a good condition, UL listed, 3-wire grounded, #14 AWG extension cord of the shortest possible length.

The TX600 is now ready to recover and recycle refrigerant.

Open valves on high and low Gauge Manifold Hoses.

Open high and low valves on Gauge Manifold.

Open valves on both Yellow Service Hoses.

Open VAPOR Valve on refrigerant cylinder.

Confirm that the Overfill Protection Device is connected.

Push Top of Main Power Switch to turn TX600 ON.

The Main Power Switch and Compressor-On light will illuminate. The Compressor and Condenser Fan will be heard operating as refrigerant is recovered from the A/C System.

The TX600 will recover refrigerant until a vacuum is sensed. The Compressor will turn off and the Compressor-On Light will turn off.

! DO NOT TURN THE TX600 OFF OR DISCONNECT HOSES !

A small quantity of Liquid refrigerant will probably remain in the A/C System. This liquid will vaporize (boil up) and increase pressure in the system as components again warm to ambient temperature. This can be detected by observing an increasing pressure reading on the Low Side of the Gauge Manifold.

If pressure increases to a preset level, the TX600 will again start to recover refrigerant. The Compressor will turn on and the Compressor-On Light will illuminate.

Allow this sequence to repeat until the Compressor-On Light remains off continuously for at least 2 minutes.

NOTE: Several audible changes may be heard during the recycling process.
Refrigerant flow through check valves causes a "sizzle-type" sound.
These changing "noises" are normal and nothing to be concerned about.

Close valves on high and low Gauge Manifold Hoses.

Close high and low valves on Gauge Manifold.

Close Valves on both Yellow Service Hoses.

Close VAPOR Valve on refrigerant cylinder.

Push bottom of Main Power Switch to turn TX600 OFF.

CAUTION... Non-condensable Gas must be purged from refrigerant before re-use.

OIL DRAIN & RAPID AIR PURGE SYSTEM PROCEDURE

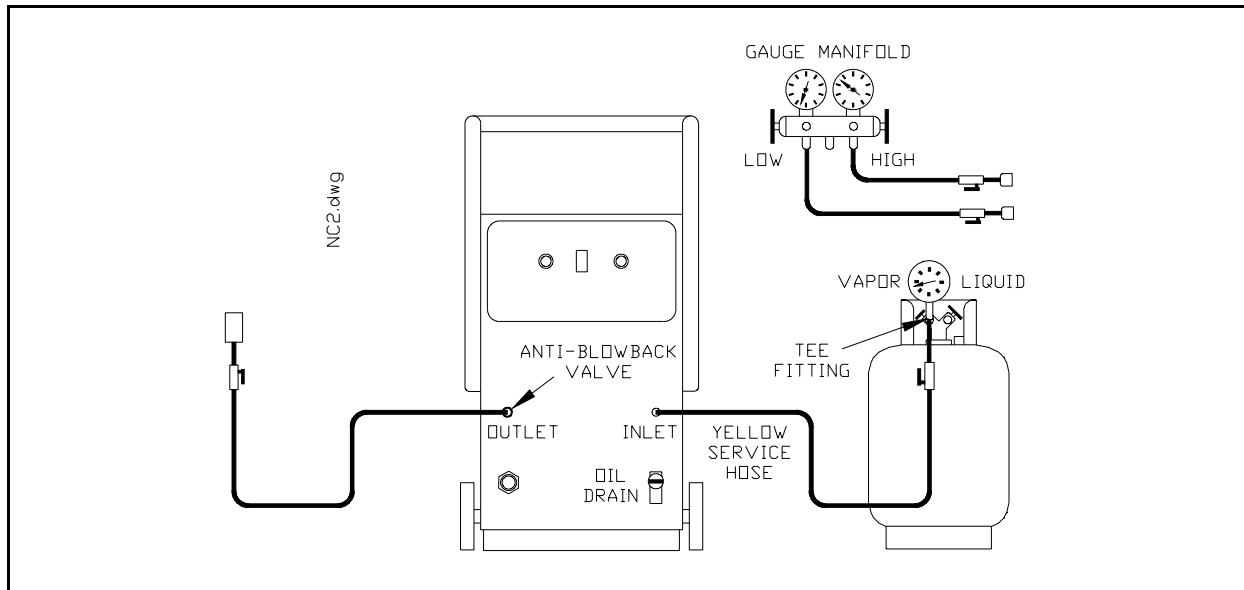

FIGURE II Connections to Vent Non-condensable Gas & Oil Drain

Oil and Non-condensable Gas (Air) are separated from the recovered refrigerant and **MUST** be removed following **EACH** recycling procedure as follows:

1. After completing the Recycle Mode, reconnect TX600 as shown in Figure II.
2. Open VAPOR Valve on Refrigerant Cylinder.
3. **SLIGHTLY** open Valve on Yellow Service Hose connected to INLET of TX600 until reading of Pressure Gauge on Refrigerant Cylinder drops approximately 2 PSIG and then immediately close the Valve.
4. **SLOWLY** open Oil Drain on the front of TX600 to vent Non-condensable Gas and drain any oil which may have been removed from the A/C System. A plastic cup is provided with the TX600 to collect and measure the oil.

Unless the A/C System had previously been overfilled, the TX600 will not remove enough oil to make replenishment necessary.

Leave Oil Drain Valve open.

5. Determine the room temperature. A Pocket Thermometer is convenient for this measurement.
6. Locate the pressure (PSIG) corresponding to this room temperature (⁰F) in Table at right.

If Pressure Gauge indicates higher than that determined from the table...

SLIGHTLY & SLOWLY open Valve on Yellow Service Hose connected to INLET of TX600 until the Pressure Gauge pressure equals that shown in the table. Any Non-condensable Gas will be vented through the Oil Drain Valve.

NOTE...

A copy of the Temperature/Pressure Table is located on the rear of the TX600 for easy reference.

7. Close the Oil Drain Valve.
8. Open Valve on Yellow Service Hose connected to the INLET of TX600 for approximately 5 seconds; then close. This permits any residual Non-condensable Gas to be recirculated for reprocessing during the next recycle procedure.
9. Close VAPOR Valve on Refrigerant Cylinder.

Non-condensable Gas has now been removed and the refrigerant is ready for charging back into an A/C System.

CAUTION...

The preceding Recycling and Purge Procedures allow the Yellow Service Hoses to remain permanently connected to the TX600. Disconnecting either hose from the TX600 may vent refrigerant unnecessarily or introduce air into the system and should be avoided.

The Yellow Service Hoses should remain connected to the TX600 unless repair or transport is required.

SEE NEXT PAGE FOR ALTERNATE PROCEDURE...

⁰ F	PSIG
30	42
32	44
34	46
36	48
38	50
40	52
42	54
44	57
46	59
48	61
50	64
52	66
54	69
56	72
58	74
60	77
62	80
64	83
66	85
68	88
70	92
72	95
74	98
76	102
78	105
80	108
82	112
84	115
86	118
88	123
90	127
92	130
94	135
96	138
98	143
100	147
102	150
104	155
106	160
108	165
110	168
112	173
114	178
116	183
118	188
120	193

ALTERNATE PROCEDURE... OIL DRAIN & RAPID AIR PURGE

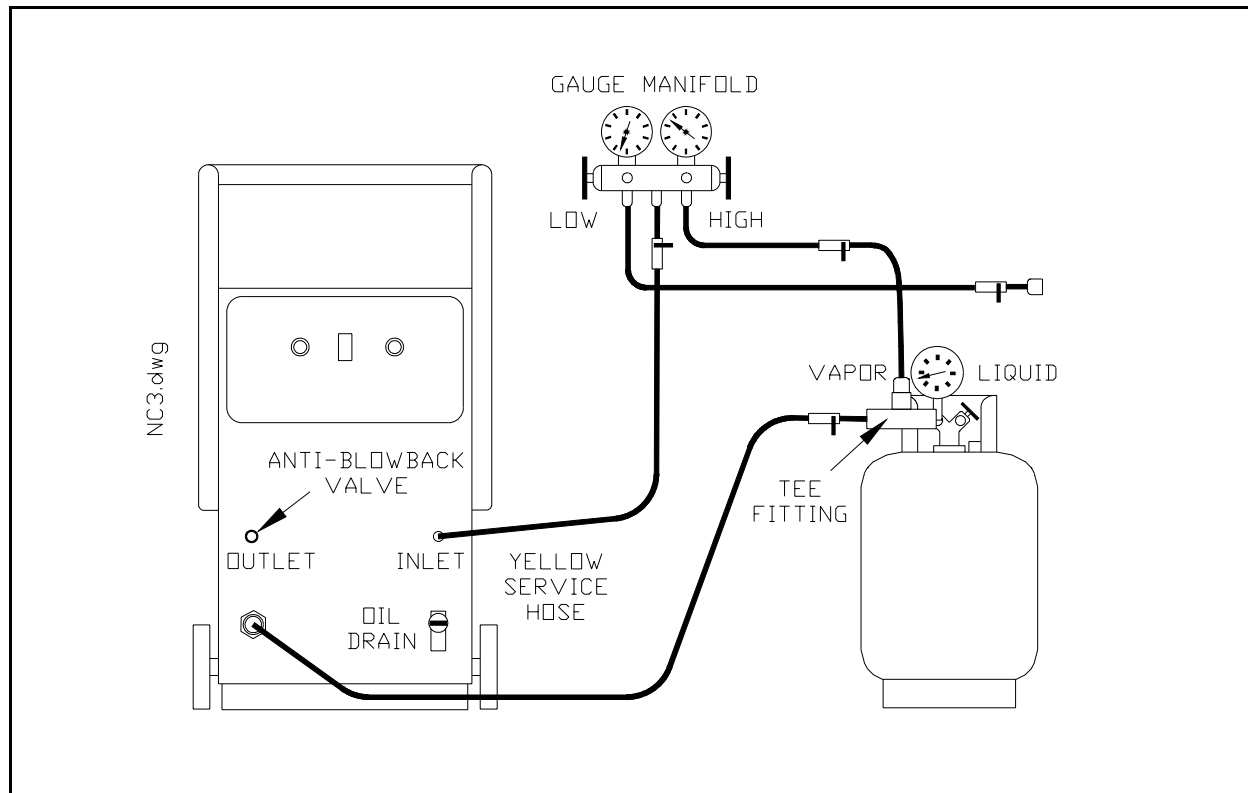

FIGURE III Alternate Connections to Vent Non-condensable Gas

Figure III illustrates an alternate method of connecting devices to drain oil and vent Non-condensable Gas from the recovered refrigerant.

The High Side Gauge of the Gauge Manifold is used, instead of the Pressure Gauge supplied with the TX600.

This method allows Rapid Air Purge without disconnecting Outlet Service Hose from Refrigerant Cylinder.

IMPORTANT... A Valve Core must be installed in the Branch of the Tee Fitting if this configuration is used.

Connect hoses as shown and then follow the instructions for draining oil and venting Non-condensable Gas described on the preceding pages.

HOW THE TX600 RECOVERS & RECYCLES REFRIGERANT

Following is a description of the purpose and performance characteristics of the components within the TX600. The items are discussed in the order as seen by refrigerant as it flows through the unit from the Inlet Port.

Refer to the Flow and Circuit Diagrams in the Appendix.

SUCTION ACCUMULATOR

Vapor and/or saturated liquid refrigerant from the vehicle A/C system enter the Suction Accumulator from the Inlet.

Refrigerant, still in the liquid state, will expand and vaporize in the Suction Accumulator due to the increase in volume.

The refrigerant changes direction of travel as it passes through the Suction Accumulator. Oil droplets (with greater mass than the refrigerant vapor) are slung towards the container walls and against an impingement plate where they collect and migrate to the bottom.

This oil is removed from the Suction Accumulator through the Oil Drain Valve.

The Low Pressure Switch, mounted on the Suction Accumulator, opens when the required vacuum is detected. This stops the recycle process.

COMBO FILTER

Moisture and acid are removed by desiccant.

SUCTION SHUTDOWN SOLENOID (S-11)

Prevents migration of refrigerant to the Compressor when the TX600 is not operating.

SUCTION PRESSURE REGULATOR

Limits refrigerant flow, during high flow rate conditions, to maintain an even rate of refrigerant processing.

This valve is set at the factory and is not adjustable.

CHECK VALVE (1 PSI)

The Check Valve permits forward refrigerant flow when the inlet pressure is 1 lb. or greater than the outlet pressure. The primary purpose of this Check Valve is to prevent reverse flow of oil to the Combo Filter during return of oil to the Compressor.

COMPRESSOR

Creates a vacuum on the recycle side of the TX600 and pumps to the filtering and condensing section.

A sight tube is mounted on the Compressor for monitoring the oil level.

HIGH PRESSURE SWITCH

Stops the Recycling process in the event of excessive Compressor discharge pressure.

This condition can be detected because the Compressor On Light will go off and the Condenser Fan will still be running.

COMBO FILTER

A patented process removes moisture and oil from the refrigerant which is in a vapor state.

Any oil removed collects in the bottom of the canister and is recirculated to the Compressor via Solenoid S12.

CHECK VALVE (1 PSI)

Prevents reverse migration of refrigerant into the Combo Filter when the TX600 is not operating and during Filter changes.

CONDENSER (COOLED BY FAN)

The high temperature, high pressure refrigerant vapor is cooled by air moving over the finned Condenser. The vapor condenses into liquid form as it is cooled.

MOISTURE INDICATOR

As liquid refrigerant flows through the Moisture Indicator, an H₂O-sensitive paper will change from blue/pink to "bright pink" if the moisture content is too high. This indicator may show pink when the TX600 is new or immediately after a filter change.

CHECK VALVE (1 PSI)

Prevents reverse flow to the Condenser during shut down.

SCHEDULED MAINTENANCE

BEFORE EACH USE...

Check the oil level in the Compressor *DAILY* before using the TX600. The Oil Level Sight Tube is visible through a cut-out on the right side of the unit.

The oil level should be visible in the cut-out and within the range indicated in the illustration.

If oil is not visible or is above the middle of the cut-out call the Warranty Repair Number:

717-840-0678 (Ext. 259)

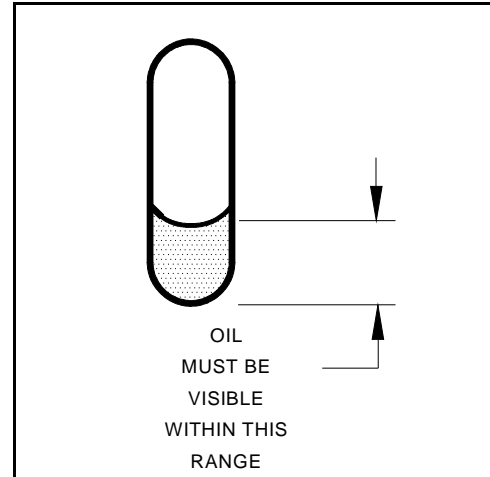

AFTER EVERY 10 HOURS OF OPERATION...

Clean the Condenser to maintain high efficiency performance of the TX600. Disconnect power and remove the Rear Access Cover. Blow compressed air through the cooling fins of the Condenser to remove any debris.

Replace the Rear Access Cover before applying power to the TX600.

CHANGE COMPRESSOR OIL... YEARLY

The oil in the Compressor should be changed yearly (or after approximately 50 hours use in a high volume shop). The best time to schedule this procedure is at the end of the peak season, just prior to "storing" the TX600.

Contact the manufacturer at 717-840-0678 (Ext. 233) for a Special Oil Change Kit and instructions.

An Oil Drain Fitting is provided on the rear of the unit for draining the Compressor Oil.

COMBO FILTER REPLACEMENT

Monitor the Moisture Indicator for a color change from BLUE to PINK. When the TX600 is new and immediately after changing Combo Filters, the Moisture Indicator may show PINK. This is due to the exposure to air and does not indicate inadequate filter performance.

Two Combo Filters are installed inside the TX600.

The Outlet Combo Filter can be identified by the presence of insulation around the outside. This Outlet Combo Filter must be changed after every 50 hours operation **OR** when Moisture Indicator shows "Bright Pink".

The Inlet Combo Filter does not have insulation around the outside. This Inlet Combo Filter must be changed after every 25 hours operation **OR** when the Moisture Indicator show "Bright Pink".

Replace Combo Filters as follows:

Remove Rear Access Cover.

Disconnect Flare Adaptor Fittings at top and bottom of Filters.

Remove the mounting screws and remove Filters.

Remove the black insulation from the one filter and re-install on the new Filter.

NOTE... Remove the Valve Core from bottom port of the Filter which has the black insulation installed around it. This Filter has a copper tube connected to the bottom port for returning oil to the Compressor.

Install new Filters using the hardware removed earlier.

Connect Flare Adaptor Fittings to top and bottom of Filters.

Check for leaks and repair as required.

Replace Rear Access Cover.

PROBLEMS & SOLUTIONS

On rare occasion the TX600 may seem to be performing differently or not at all. Experience has shown that varying operating conditions can affect the performance characteristics of the TX600. The temperature of the vehicle A/C System will affect how the TX600 performs.

Following are typical problems with explanations of the possible cause and solution.

PROBLEM: My TX600 was recovering refrigerant and the Compressor On light went OFF which indicates the A/C System should be in a vacuum. However, the Manifold Gauge still shows a pressure.

SOLUTION Determine if the Condenser Cooling Fan is still running. The fan can be heard and air flow through the TX600 can be felt. If the fan **is running**, the high pressure switch has shut the TX600 off due to an over-pressure condition.

Turn the Power Switch OFF and then ON. The condition may correct itself. This over-pressure will typically be due to excessive pressure in the External Cylinder caused by Non-condensable Gas (Air). Refer to the "Oil Drain & Rapid Air Purge Procedure" Section of this manual and follow the instructions to vent the Non-condensable gas.

PROBLEM: My TX600 worked fine all last Summer. I got it out today for the first service job this Spring and it is very slow in evacuating the system.

SOLUTION: Today's Spring temperature may be much lower than the average temperatures during the summer months. Maybe the vehicle was brought in from outside where the temperature is very low.

The refrigerant in the vehicle will not be under as high a pressure at lower temperatures and the TX600 will take longer to draw a vacuum. More cycles may be required to completely recover the refrigerant.

PROBLEM: I can not get the TX600 to draw a vacuum as indicated on the Low Side Manifold Gauge.

SOLUTION: Check Manifold Gauge and Hoses for restrictions.



IF A CYLINDER IS TURNED UP-SIDE-DOWN, THE TX600 WILL OVERFILL WITH LIQUID REFRIGERANT. THIS OVER FILLS THE SUCTION ACCUMULATOR WITH LIQUID.

FROST ON THE OIL DRAIN OR SUCTION ACCUMULATOR OF THE TX600 IS A GOOD INDICATION OF THIS OCCURRENCE.

THIS SYMPTOM IS CAUSE FOR CONCERN AS LIQUID REFRIGERANT WILL BE FORCED INTO THE COMPRESSOR.

THIS CAN DESTROY THE COMPRESSOR AND WILL VOID THE WARRANTY.

The safest method to remove the excess liquid which has collected in the Suction Accumulator is to drain it from the Oil Drain on the front of the TX600 as follows:

Draw a deep vacuum (25 to 29 In. Hg.) on an empty cylinder and connect it to the Oil Drain Valve. Open the cylinder valve and the Oil Drain valve.

Close the valves and disconnect the cylinder after the liquid has been drawn into the cylinder. This refrigerant should now be recycled by the TX600 following normal recycling procedures.

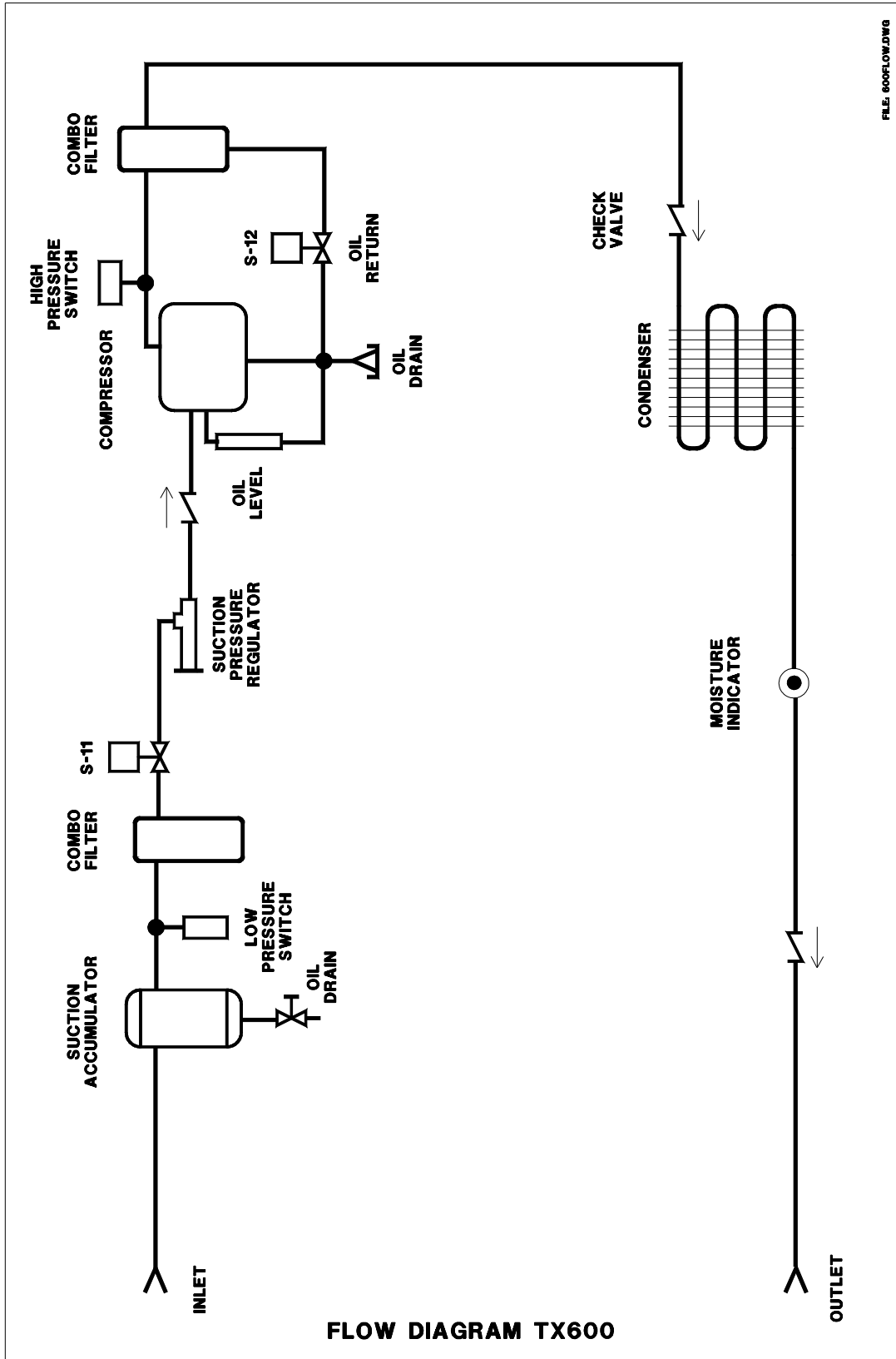

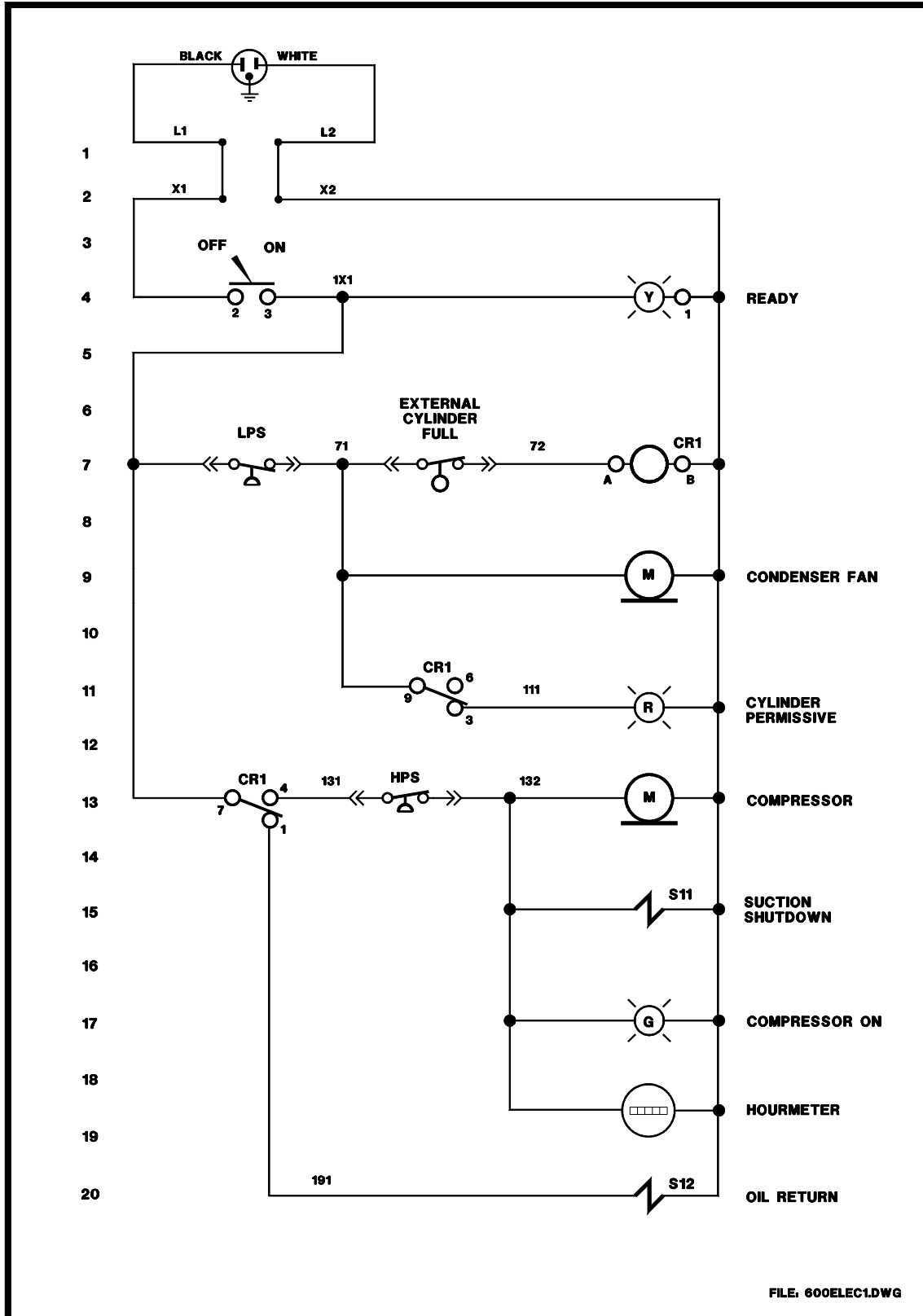

600 SCHEMATIC

WHEELKIT.DWG

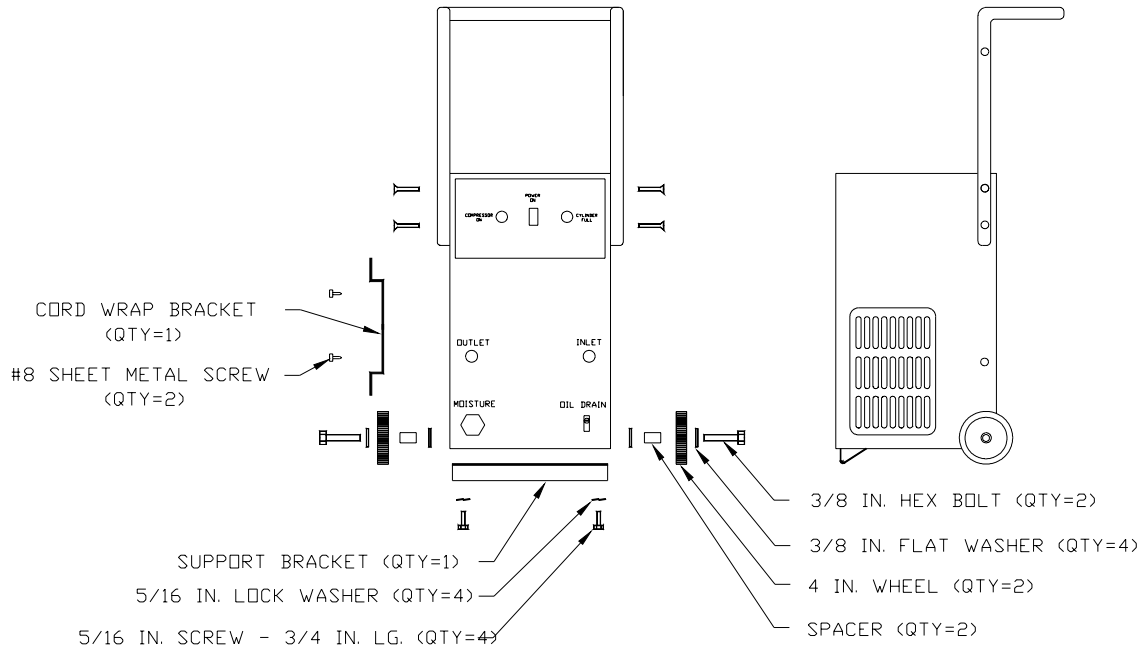

HANDLE MOUNTED IN UPPER POSITION

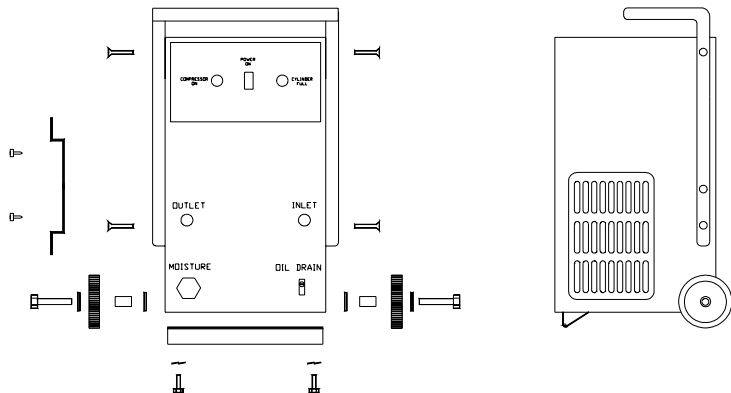

HANDLE MOUNTED IN LOWER POSITION

560-80034-00